

CM 42

OPERATING INSTRUCTIONS

Translation of the original instructions





Declaration of conformity

The undersigned manufacturer:

SAINT - GOBAIN ABRASIVES S.A.
190, BD J.F. KENNEDY
L- 4930 BASCHARAGE

Declares that this product:

Masonry Saws: **CM 42 115V UK**
CM 42 230V UK
CM 42 230V

Code: **70184647990**
70184647989
70184647620

is in conformity with the following Directives:

- **"MACHINES" 2006/42/CE**
- **"LOW VOLTAGE" 2006/95/CE**
- **"ELECTROMAGNETIC COMPATIBILITY" 2004/108/CE**
- **"NOISE" 2000/14/CE**

and European standard:

- **EN 12418 – Masonry and stone cutting-off machines – Safety**

Valid for machines as of serial number:

130400000

Storage site for the technical documents :

Saint-Gobain Abrasives 190, Bd. J. F. Kennedy 4930 BASCHARAGE, LUXEMBOURG

This declaration of conformity loses its validity when the product is converted or modified without agreement.

Bascharage, Luxembourg, 01.04.2013

A handwritten signature in black ink, appearing to read "Olivier Plenert", written over a light blue horizontal line.

Olivier Plenert, executive officer.

CM 42

OPERATING INSTRUCTIONS

TABLE OF CONTENTS

<u>1</u>	<u>BASIC SAFETY INSTRUCTIONS.....</u>	<u>5</u>
1.1	<i>Symbols</i>	5
1.2	<i>Machine plate.....</i>	6
1.3	<i>Safety instructions for particular operating phases</i>	6
<u>2</u>	<u>MACHINE DESCRIPTION</u>	<u>7</u>
2.1	<i>Short description.....</i>	7
2.2	<i>Purpose of use</i>	7
2.3	<i>Layout</i>	7
2.4	<i>Technical data</i>	9
2.5	<i>Statement regarding the vibration emission</i>	10
2.6	<i>Statement regarding noise emission</i>	11
<u>3</u>	<u>ASSEMBLY AND COMMISSIONING</u>	<u>12</u>
3.1	<i>Tool assembly</i>	12
3.2	<i>Implementation of elements</i>	12
3.3	<i>Electrical connections.....</i>	12
3.4	<i>Starting the machine</i>	13
3.5	<i>Water cooling system</i>	13
<u>4</u>	<u>TRANSPORT AND STORING</u>	<u>14</u>
4.1	<i>Securing for transport.....</i>	14
4.2	<i>Transportation procedure.....</i>	14
4.3	<i>Long period of inactivity</i>	14
<u>5</u>	<u>OPERATING THE MACHINE</u>	<u>15</u>
5.1	<i>Site of work.....</i>	15
5.2	<i>Cutting methods.....</i>	15
<u>6</u>	<u>MAINTENANCE AND SERVICING.....</u>	<u>17</u>
<u>7</u>	<u>FAULTS : CAUSES AND CURES</u>	<u>18</u>
7.1	<i>Fault-finding procedures</i>	18
7.2	<i>Trouble-shooting guide.....</i>	18
7.3	<i>Circuit diagram</i>	19
7.4	<i>Customer service</i>	21

1 BASIC SAFETY INSTRUCTIONS

The CM 42 is exclusively designed for the cutting of construction products mainly on construction sites.

Uses other than the manufacturer's instructions shall be considered as contravening the regulations. The manufacturer shall not be held responsible for any resulting damage. Any risk shall be borne entirely by the user. Observing the operating instructions and compliance with inspection and servicing requirements shall also be considered as included under use in accordance with the regulations.

1.1 Symbols

Important warnings and pieces of advice are indicated on the machine using symbols. The following symbols are used on the machine:



Read operator's instructions



Ear protection must be worn



Hand protection must be worn



Eye protection shall be worn

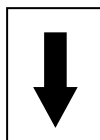

Rotation direction of the blade



Danger: risk of cut

1.2 Machine plate

Important data can be found on the following plate located on the machine:

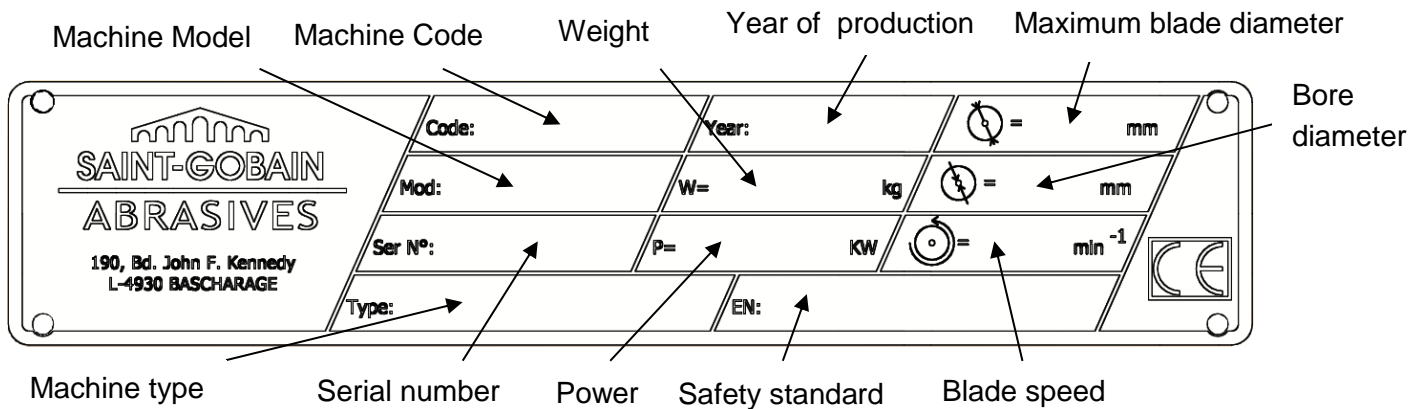

1.3 Safety instructions for particular operating phases

Before commencing work

- Before commencing work, make yourself familiar with the working environment at the place of use. The working environment includes: obstacles in the area of work and manoeuvre, the firmness of the floor, necessary protection at the site relating to public thoroughfares and the availability of help in the event of accidents.
- Check for correct mounting of the blade regularly.
- Immediately remove damaged or badly worn blades, as they endanger the operator whilst rotating.
- Only fit NORTON diamond blades to the machine! The use of other tools can damage the machine!
- Attention is drawn to the use of BS2092 safety goggles in conformity with specified Processes No.8 of the Protection of Eyes Regulation 1974, Regulation 2(2) Part 1.
- Use of ear and hand protection is compulsory.
- For security reasons, never leave the machine unattended, untied or unlocked.

While the engine is running

- Do not move the machine whilst the blade is running idle.
- Always cut with the blade guard in position.

2 MACHINE DESCRIPTION

Any modification, which could lead to a change in the original characteristics of the machine, may be done only by Saint-Gobain Abrasives who shall confirm that the machine is still in conformity with the safety regulations.

2.1 Short description

The CM 42 Masonry saw is designed for durability and high performance for onsite wet and dry cutting operations of a wide range of masonry, refractory and natural stone products. As with all other CLIPPER products, the operator will immediately appreciate the attention given to detail and quality of materials used in construction. The machine and its component parts are assembled to high standards assuring long life and minimum maintenance.

2.2 Purpose of use

The machine is designed for wet and dry cutting of a large range of building and refractory materials, or tiles. **It is not designed for cutting wood or metals.**

2.3 Layout



Frame and feet (1)

The frame is made of a jig-welded reinforced steel construction to ensure perfect rigidity. 4 removable legs fit into housings welded on frame sides and locked into place with wing screws. The front feet are adjustable. It is also equipped with wheels and handles for transportation.

Cutting head (2)

Spring loaded jig-welded steel console. The motor fixing points and the pivot are machined for perfect fit. A locking system allows straight-through cutting without any other accessory.

Blade guard (3)

Jig-welded steel construction with 400mm-diameter blade capacity, which offers maximum operator protection and increased visibility of the work piece.

Incorporated in the blade guard is an outer metal cover, which can be easily removed to allow easy access to shaft for inspection and blade replacement when motor is switched off, while fully protecting the blade when in operation.

Electrical motor (4)

2.2 kW (1.8 kW for 115V) electrical motor with an overload protection. Low voltage trigger (NVR) built in the switch prevents the motor to restart for example after a power cut. Thermal overload tripping can occur for two reasons:

- a) Tripping under light load if connection is incorrect
- b) Tripping under heavy load if motor has been overloaded.

The ON-OFF switch also serves as emergency stop.

Conveyor cart (5)

Steel welded construction with non-slip top. As an accessory, a conveyor can tilt from 0 to 45° for angle bevel tile cutting.

The machine guide system permits precise cuts to be made by virtue of four roller sheaves set at an inclination to compensate for wear. The nylon-plastic sheaves and sealed-bearings permit easy operation. Precise positioning of the material is possible thanks to the large surface area of the conveyor cart and the variable angle guide-a-cut. The table has an anti-dumping system and a locking latch.

Water cooling system (6)

The coolant system comprises:

- A powerful, submersible electric water pump.
- Plastic suction pipe delivering the water from the water pan to the cutting head.
- A large capacity water pan supplied with drain plug.
- A water-tap, fitted to the blade guard, permitting controlled water flow.
- Two water nozzles located on the blade guard ensure adequate flow of water to both sides of the cutting blade.
- A water curtain, fixed to head axle restricts water spray and minimizes water loss.
- The pump switch is located on the right side of the main switch.

Attention: The water pump must never run without water.

2.4 Technical data

Electric motor	1,8 kW 115V with thermal overload protection 2,2 kW 230V with thermal overload protection
Electric motor protection	IP54
Max. blade diameter	400mm
Bore	25,4mm
Rotation speed of the blade	2800 min ⁻¹
Flange diameter	135mm (without reversing the material)
Cutting depth mm	90mm
Sound pressure level	80 dB (A) (ISO EN 11201)
Sound energy level	92 dB (A) (ISO EN 3744)
Max. cutting length mm	600mm
Table dimension (L x W)	500x540mm
Machine dimensions feet folded (L x W x H)	1187x741x729mm
Machine dimensions feet unfolded (L x W x H)	1187x741x1355mm
Weights:	
Fully equipped	90 kg
Ready for use (with water)	132 kg

2.5 Statement regarding the vibration emission

Declared value of vibration emission following **EN 12096**.

Machine Model / code	Measured value of vibration emission at m/s ²	Uncertainty K m/s ²	Tool used Model / code
CM 42 115V UK 70184647990	<2.5	0.5	Clipper ALFA
CM 42 230V UK 70184647989			
CM 42 230V 70184647620			

- The vibration value is lower and does not exceed 2.5 m / s.
- Values determined using the procedure described in the standard **EN 12418**.
- The measurements are made with new machines. Actual values may vary with site conditions, in terms of:
 - Materials worked
 - Wear Machine
 - Lack of maintenance
 - Inappropriate tool for application
 - Tool in poor condition
 - Unskilled operator
 - Etc...
- The exposure time to vibration is based on the performance of work (related to the adequacy Machine / Tool / worked material / operator)

When evaluating risks due to hand-arm vibration, you need to take into account effective usage at rated power of machine during a full day of work; quite often you will realise that effective utilisation time represents around 50% of overall duration of work. You have to consider, of course, breaks, water feeding, preparation of work, time to move the machine, disk mounting...

2.6 Statement regarding noise emission

Declared value of noise emission following **EN ISO 11201** and **NF EN ISO 3744**.

Machine Model / code	Sound Pressure level L_{Peq} EN ISO 11201	Uncertainty K (Sound Pressure level L_{Peq} EN ISO 11201)	Sound power level L_{Weq} NF EN ISO 3744	Uncertainty K (Sound power level L_{Weq} NF EN ISO 3744)
CM 42 115V UK 70184647990	80 dB(A)	2.5 dB(A)	92 dB(A)	4 dB(A)
CM 42 230V UK 70184647989				
CM 42 230V 70184647620				

- Values determined using the procedure described in the standard **EN 12418**.
- The measurements are made with new machines. Actual values may vary with site conditions, in terms of:
 - Wear Machine
 - Lack of maintenance
 - Inappropriate tool for application
 - Tool in poor condition
 - Unskilled operator
 - Etc...
- Measured values relate to an operator in normal use, as described in the manual position.

3 ASSEMBLY AND COMMISSIONING

The machine is delivered fully equipped (although without diamond blade). It is ready for operation when you mount the diamond blade, the handles and the conveyor cart and after you connect to the appropriate power supply.

3.1 *Tool assembly*

Only NORTON blades with a maximum diameter of 400 mm can be used with the CM 42.

All tools used must be selected with regard to their maximum permitted cutting speed for the machine's maximum permitted rotation speed. Before mounting a new blade into the machine, switch off the machine and isolate it from the main source of electricity.

To mount a new blade, follow these steps:

- Loosen the screw in front of the blade guard and disconnect the water hose on its the left side and open it.
- Loosen the hexagonal nut on the blade shaft (**attention:** left threaded), which holds the removable outer flange, with the supplied wrench.
- Remove the outer flange.
- Clean the flanges and blade shaft and inspect for wear.
- Mount the blade on arbour ensuring that direction of rotation is correct. Wrong direction of rotation blunts the blade quickly.
- Replace outer blade flange.
- Tighten the hexagonal (**attention:** left threaded), nut with the supplied wrench.
- Close the blade guard, retighten the screw on the front of the blade guard and reconnect the water hose.

ATTENTION: The blade bore must correspond exactly to the diameter of the blade shaft. Cracked or damaged bore is dangerous for the operator and for the machine.

3.2 *Implementation of elements*

The machine is delivered with its transportation handles disassembled. You have to mount these handles thanks to the 4 supplied M10x25 crews.

The cutting head is locked in low-position by a hexagonal nut. Replace it by the supplied tension lever.

On the left side of the machine, feet are locked in their folded position by nuts. Replace them by the supplied tension levers then unfold the feet and lock them with the tension levers.

3.3 *Electrical connections*

Check that,

- The voltage/phase supply corresponds to the information indicated on the motor plate.
- Available power supply must have ground connection in conformity with safety regulations.
- The connecting cables should have at least a 2.5mm²-section per phase.

3.4 *Starting the machine*

Open the cover on the switch and press the green button to start the machine. Either press on the red button or directly on the switch cover to stop the machine.

3.5 *Water cooling system*

- Fill the water pan with clean water to approximately 2cm from top (ensure that bottom of pump is fully immersed in water). Use the pump switch on the side of the main switch to start the pump.
- Open the water-tap on blade guard (note that handle on water-tap should be in line with water-flow).
- Ensure that water is flowing freely in the circuit and is delivered adequately to both sides of the blade, as insufficient water supply may result in premature failure of the diamond blade.
- The water pump must never run without water. Always make sure that there is enough water in the pan and refill if necessary.
- In case of frost, empty the water cooling system from its water.

4 TRANSPORT AND STORING

4.1 *Securing for transport*

Before transporting the machine, always remove the blade and empty the water pan. Lock the conveyor thanks to the latch.

4.2 *Transportation procedure*

There are two ways to move the machine: By one person, its feet folded and making use of the transport wheels, or by two persons with its feet folded or unfolded.

Always fold the feet while transporting the machine in a van or truck.

The machine does not have lifting hooks.

4.3 *Long period of inactivity*

If the machine is not going to be used for a long period, please take the following measures:

- Completely clean the machine
- Empty the water system
- Take the water pump out of the slurry and clean it thoroughly.

The storage site must be clean, dry and at a constant temperature.

5 OPERATING THE MACHINE

You will find in this chapter some advice about where and how to put up the machine.

5.1 *Site of work*

5.1.1 Siting the machine

- Remove from the site anything, which might hinder the working procedure!
- Make sure the site is sufficiently well lit!
- Observe manufacturer's conditions for connecting to power supplies!
- Place electric cables in such a way that damage is excluded!
- Make sure you have a continual adequate view of the working area so you can intervene in the working process at any time!
- Keep other staff out of the area, so you can work securely.

5.1.2 Area dedicated for the use and maintenance of the machine

You should have 2 m in front of the machine and 1,5 m on both sides to get a comfortable use of the machine.

5.2 *Cutting methods*

To use the machine correctly, you must face it with one hand on the handle of the cutting head, and the other on the conveyor cart. Always keep your hands away from the moving blade. Open the switch cover and press the green button to start the machine. To stop either use the red button or press directly on the switch front cover.

5.2.1 Full depth or fixed cutting

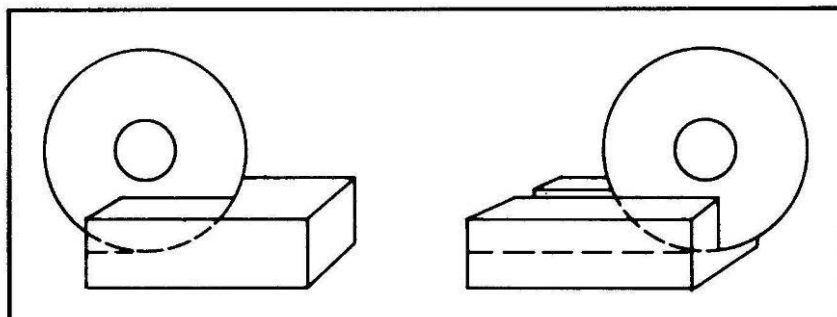

In full depth or fixed cutting, the cutting head is locked in a fixed position and the material is pushed into it as shown.

- Lower the cutting head to the desired cutting depth (in “through cutting”, lower cutting head until blade periphery reaches max. 3mm under the surface of the conveyor cart) by means of the handle on the blade guard
- Fix position by tightening the clamping device
- Put material on conveyor cart
- Start the machine

- Push the conveyor cart slowly and without undue pressure towards the rotating blade and cut the material as shown on the picture.

NOTE: While recommended, it is not absolutely necessary to lock the cutting head into a given depth position when jam cutting. The desired cutting depth can be maintained by holding firmly the depth feed handle on the blade guard. If the full depth of cut requires excessive pressure (on very dense material e.g.) make 2 or 3 shallow cuts.

5.2.2 Multiple step cutting

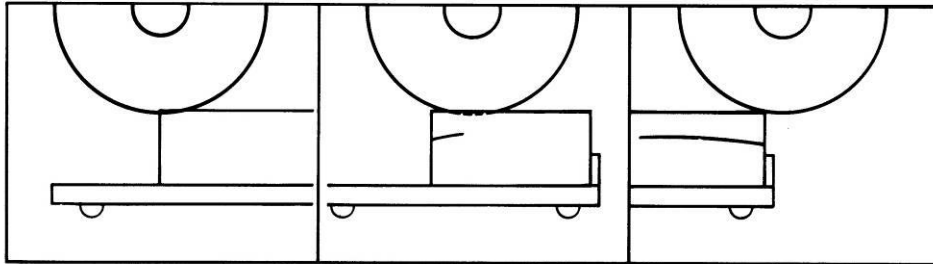

Multiple step cutting consists of moving the conveyor cart with the material to be cut back and forward under the rotating blade,

- Place the material to be cut on the conveyor cart firmly against the guide-a-cut and the backstop, keeping the hands well away from the blade.
- Start the machine.
- Move conveyor cart forward near the blade and pull down the cutting head until blade is lowered to a point where it will lightly contact the surface of the material.
- Pass the material beneath with rapid full length strokes, taking a shallow cut (approximately 3 mm deep as shown on the picture) on the forward. On the backward stroke, lift the blade just clear over the cutting line.
- Complete each rapid stroke backward and forward by passing the material beyond the centre of the blade before starting the reverse movement of the conveyor cart.

NOTE: the harder the material, the more rapid should be the forward and backward strokes.

Step cutting lessens the area of the blade circumference in contact with the material, keeping the blade cool, running free and cutting at peak efficiency.

5.2.3 General advice for the cutting

- Material weight under 30 kg and having dimensions smaller than 600x600x135mm can be cut with the machine.
- Before commencing work make sure tools are firmly seated!
- Select the right tools as recommended by the manufacturer depending on the material to be worked, the working procedure (dry or wet cut) to be carried out and the required efficiency.
- Apply cooling water continuously whilst cutting and in good time! Make sure the water pan contains enough water.
- In case the thermal protection trips, wait until the motor has cooled down before starting the machine again.

6 MAINTENANCE AND SERVICING

To ensure a long-term quality from the cutting with the CM 42, please follow the maintenance plan below :

		At the beginning of a working day	During the change of tool	At the end of a working day	Every week	After a fault	After a damage
Whole machine	Visual control (general aspect, water tightness)						
	Clean						
Flange and blade fixing devices	Clean						
Motor cooling fans	Clean						
Water pump	Clean						
Water pan	Clean						
Water tank	Clean						
Water hoses and nozzles	Clean						
Water pump filter	Clean						
Cart guiding bars	Clean						
Motor housing	Clean						
Reachable nuts and screws	Tighten						

Maintenance of the machine

Always perform the maintenance of the machine with the machine isolated from the electrical supply.

Lubrication

The CM 42 uses life-lubricated bearings. Therefore, you don't need to lubricate the machine at all.

Cleaning of the machine

Your machine will last longer if you clean it thoroughly after each day of work, especially water pump, water pan (which can be removed for easy cleaning), motor and blade flange.

7 FAULTS : CAUSES AND CURES

7.1 *Fault-finding procedures*

Should any fault occur during the use of the machine, turn it off, and isolate it from the electrical supply. Any works dealing with the electrical system or supply of the machine can only be carried out by a qualified electrician.

7.2 *Trouble-shooting guide*

Trouble	Possible source	Resolution
Motor is not running	No electricity	Check the electrical supply (fuse for example)
	Connection cable section too small	Change connection cable
	Defective switch	CAUTION : can only be solved by a qualified electrician
	Defective motor	Change motor or contact motor manufacturer
	Defective connection cable	Change connection cable
Motor stops during the cutting, but can be restarted after a short period (overload protection)	Cutting advance too quick	Cut slowly
	Blade is blunt or glazed	Sharpen the blade every 10-15 cuts in calcareous stone
	Defective blade	Change blade
	Wrong blade specification for the application	Change blade
No water on the blade	Not enough water in the pan	Refill the water pan
	Water supply system is blocked up	Clean water supply system
	Water pump is not working	Prime the pump or reactivate the switch CAUTION : if switch trips again, problem only be solved by a qualified electrician

7.3 Circuit diagram

115V

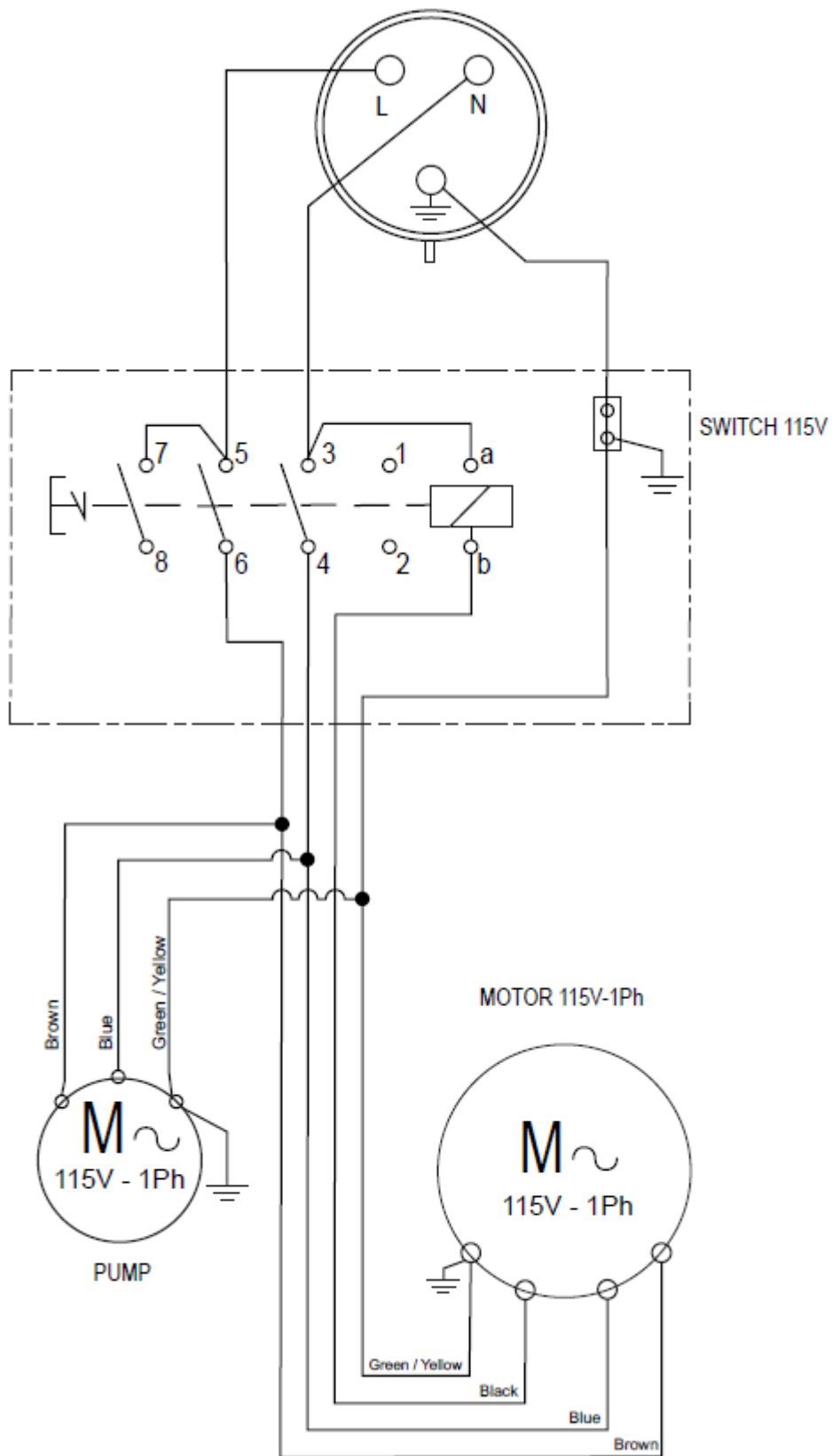

230V

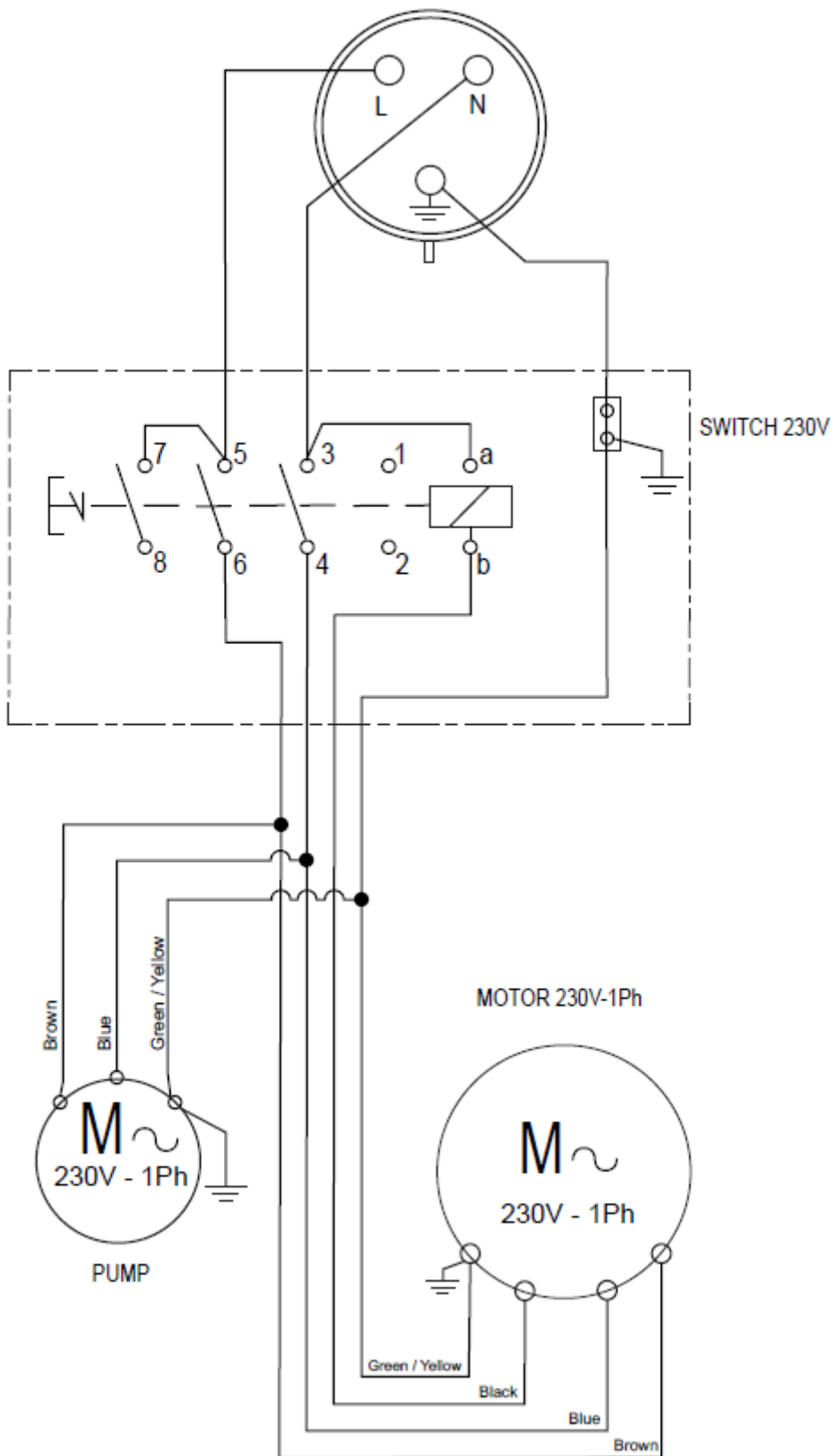

7.4 Customer service

When ordering spare parts, please mention:

- The serial number (7 digits).
- The code of the part.
- The exact denomination.
- The number of parts required.
- The delivery address.
- Please indicate clearly the means of transportation required such as "express" or "by air". Without specific instructions, we will forward the parts through the means which seem appropriate to us --- but which is not always the quickest way.

Clear instructions will avoid problems and faulty deliveries.

If not sure, please send us the defective part.

In the case of a warranty claim, the part must always be returned for evaluation.

Spare parts for the motor can be ordered with the manufacturer of the motor or with their dealer, which is often quicker and cheaper.

This machine has been manufactured by: Saint-Gobain Abrasives S.A.

190, Bd. J. F. Kennedy
L- 4930 BASCHARAGE
Grand-duché de Luxembourg.
Tel.: 00352-50 401-1
Fax: 00352- 50 16 33
<http://www.construction.norton.eu>
e-mail: sales.nlx@saint-gobain.com

Guarantee can be claimed and technical support obtained from your local distributor where machines, spare parts and consumables can be ordered as well:

SAINT-GOBAIN ABRASIVES NV/SA
INDUSTRIELAAN 129
1070 ANDERLECHT /BRUSSEL
BELGIUM
TEL: +32 (0)2 267 21 00
FAX: +32 (0)2 267 84 24

SAINT-GOBAIN ABRASIVES, S.R.O.
POČERNICKÁ 272/96, MALEŠICE
108 00 PRAHA 10
CZECH REPUBLIC
TEL: +420 255 719 326
FAX: +420 255 719 321

SAINT-GOBAIN ABRASIVES A/S
ROBERT JACOBSENS VEJ 62A
2300 KØBENHAVN S
DENMARK
TEL: +45 4675 5244

PO BOX 643706
FORTUNE TOWER OFFICE 2106
JLT BLOCK C
(NEXT TO METRO STATION)
JUMEIRA LAKE TOWER, DUBAI
UNITED ARAB EMIRATES
TEL: +971 4 431 5154
FAX: +971 4 431 5434

SAINT-GOBAIN ABRASIFS
RUE DE L'AMBASSADEUR - B.P.8
78 702 CONFLANS CEDEX
FRANCE
TEL: +33 (0)1 34 90 40 00
FAX: +33 (0)1 39 19 89 56

SAINT-GOBAIN ABRASIVES GMBH
BIRKENSTRASSE 45-49
D-50389 WESSELING
GERMANY
TEL: +49 (0) 2236 703-1
+49 (0) 2236 8996-0
+49 (0) 2236 8911-0
FAX: +49 (0) 2236 703-367
+49 (0) 2236 8996-10
+49 (0) 2236 8911-30

FÜR DEN FACHHANDEL
ÖSTERREICH
TEL: +43 (00) 662 430 076

SAINT-GOBAIN ABRASIVES KFT.
1225 BUDAPEST
BÁNYALÉG U. 60/B.
HUNGARY
TEL: +36 1 371 22 50
FAX: +36 1 371 22 55

SAINT-GOBAIN ABRASIVI S.P.A
VIA PER CESANO BOSCONI 4
I-20094 CORSICO MILANO
ITALY
TEL: +39 02 44 851
FAX: +39 02 44 78 266

SAINT-GOBAIN ABRASIVES S.A.
190 RUE J.F. KENNEDY
L-4930 BASCHARAGE
GRAND DUCHE DE LUXEMBOURG
TEL: +352 50 401 1
FAX: +352 50 16 33
NO. VERT (FRANCE) 0800 906 903

SAINT-GOBAIN ABRASIFS, S.A.
2 ALLÉE DES FIGUIERS
AIN SEBAË - CASABLANCA
MOROCCO
TEL: +212 5 22 66 57 31
FAX: +212 5 22 35 09 65

SAINT-GOBAIN ABRASIVES BV
GROENLOSEWEG 28
7151 HW EIBERGEN
P.O. BOX 10
7150 AA EIBERGEN
THE NETHERLANDS
TEL: +31 545 466466
FAX: +31 545 474605

SAINT-GOBAIN ABRASIVES AS
POSTBOKS 11, ALNABRU,
0614 OSLO
BROBEKKVEIEN 84,
0582 OSLO
NORWAY
TEL: +47 63 87 06 00
FAX: +47 63 87 06 01

SAINT-GOBAIN HPM POLSKA SP. Z O.O.
UL. NORTON 1
62-600 KOŁO
POLAND
TEL: +48 63 26 17 100
FAX: +48 63 27 20 401

SAINT-GOBAIN ABRASIVOS, L. DA
ZONA INDUSTRIAL DA MAIA
I-SECTOR VIII, NO. 122
APARTADO 6050
4476 - 908 MAIA
PORTUGAL
TEL: +351 229 437 940
FAX: +351 229 437 949

SAINT-GOBAIN GLASS
BUSINESS UNIT ABRASIVI
PUNCT DE LUCRU: LOC.VETIS, JUD.
SATU MARE 447355
STR. CAREIULUI 11
PARC INDUSTRIAL RENOVATIO
ROMANIA
TEL: 0040-261-839.709
FAX: 0040-261-839.710

SG HPM RUS
58, F. ENGELS STR.
STROENIE 2
105082 MOSCOW
RUSSIA
TEL: +74 955 408 355
FAX: +74 959 373 224

SAINT-GOBAIN
ABRASIVES (PTY) LTD
2 MONTEER ROAD
ISANDO 1600
P.O. BOX 67
SOUTH AFRICA
TEL: +27 11 961 2000
FAX: +27 11 961 2184/5

SAINT-GOBAIN ABRASIVOS, S.A.
CTRA. DE GUIPÚZCOA, KM. 7,5
E-31195 BERRIOPLANO (NAVARRA)
SPAIN
TEL: +34 948 306 000
FAX: +34 948 306 042

SAINT-GOBAIN ABRASIVES AB
BOX 495
SE-191 24 SOLLENTUNA
SWEDEN
TEL: +46 8 580 881 00
FAX: +46 8 580 881 01

SAINT-GOBAIN INOVATIF
MALZEMELER VE AŞINDIRICI
SAN. TIC. A.Ş.
GOLD PLAZA, ALTAY ÇEŞME
MAHALLESİ, ÖZ SOKAK, NO:19/16
34843 MALTEPE-ISTANBUL,
TURKEY
TEL: 0090-216-217 12 50
FAX: 0090-216-442 40 74

SAINT-GOBAIN ABRASIVES LTD.
DOXEY RD
STAFFORD
ST16 1EA
UNITED KINGDOM
TEL: +44 1785 222 000
FAX: +44 1785 213 487



www.construction.norton.eu

Saint-Gobain Abrasives

190, Bd. J. F. Kennedy
L-4930 BASCHARAGE
LUXEMBOURG

Tel: ++352 50401-1

Fax: ++352 501633

e-mail: sales.nlx@saint-gobain.com