

TSZ-UNI



- DE | Betriebsanleitung
- GB | Operating Instructions
- FR | Instructions d'emploi
- NL | Bedrijfshandleiding
- IT | Istruzioni d'uso

TSZ-UNI



DE | Betriebsanleitung



Bitte beachten Sie, dass das Produkt ohne vorliegende Betriebsanleitung in Landessprache nicht eingesetzt / in Betrieb gesetzt werden darf. Sollten Sie mit der Lieferung des Produkts keine Betriebsanleitung in Ihrer Landessprache erhalten haben, kontaktieren Sie uns bitte. In Länder der EU / EFTA senden wir Ihnen diese kostenlos nach. Für Länder außerhalb der EU / EFTA erstellen wir Ihnen gerne ein Angebot für eine Betriebsanleitung in Landessprache, falls die Übersetzung nicht durch den Händler/Importeur organisiert werden kann.

Please note that the product may not be used / put into operation without these operating instructions in the national language. If you did not receive operating instructions in your national language with the delivery of the product, please contact us. In countries of the EU / EFTA we will send them to you free of charge. For countries outside the EU / EFTA, we will be pleased to provide you with an offer for an operating manual in the national language if the translation cannot be organised by the dealer/importer.

Inhalt

1	EG-Konformitätserklärung	3
2	Sicherheit	4
2.1	Sicherheitshinweise.....	4
2.2	Begriffsdefinitionen.....	4
2.3	Definition Fachpersonal/ Sachkundiger	4
2.3.1	Erklärung der Piktogramme	5
2.4	Sicherheitskennzeichnung	6
2.5	Persönliche Sicherheitsmaßnahmen	7
2.6	Schutzausrüstung.....	7
2.7	Unfallschutz.....	7
2.8	Funktions- und Sichtprüfung	7
2.8.1	Mechanik.....	7
2.9	Sicherheit im Betrieb	8
2.9.1	Allgemeines.....	8
2.9.2	Trägergeräte / Hebezeuge.....	8
3	Allgemeines	9
3.1	Bestimmungsgemäßer Einsatz	9
3.2	Übersicht und Aufbau.....	11
3.3	Zubehör.....	11
3.4	Technische Daten	11
4	Installation.....	12
4.1	Mechanischer Anbau.....	12
4.1.1	Einhängeöse / Eihängebolzen	12
4.1.2	Lasthaken und Anschlagmittel	12
4.1.3	Drehköpfe (optional)	12
4.1.4	Einstecktaschen (optional).....	13
4.2	Installation der Stahlgreifpratzen WB-SQ	14
5	Einstellungen	15
5.1	Einstellung des Greifbereichs	15
5.2	Zubehör – HVA für Stapelbetrieb	17
6	Bedienung	18
6.1	Greifen, Versetzen und Ablegen von Lasten	18
6.2	Darstellung der Wechselautomatik	19
6.3	Bedienung: Stahlgreifpratzen WB-SQ.....	20
7	Wartung und Pflege.....	22
7.1	Wartung.....	22
7.1.1	Mechanik.....	22
7.1.2	Zusätzlich bei Stahlgreifpratzen (WB-SQ).....	23
7.2	Störungsbeseitigung.....	24
7.3	Reparaturen	24
7.4	Prüfungspflicht.....	25
7.5	Hinweis zum Typenschild.....	26
7.6	Hinweis zur Vermietung/Verleihung von PROBST-Geräten	26
8	Entsorgung / Recycling von Geräten und Maschinen.....	26

Änderungen gegenüber den Angaben und Abbildungen in der Betriebsanleitung sind vorbehalten.

1 EG-Konformitätserklärung

Bezeichnung: Trittstufenversetzzange TSZ
Typ: TSZ-UNI
Artikel-Nr.: 53100338



Hersteller: Probst GmbH
Gottlieb-Daimler-Straße 6
71729 Erdmannhausen, Germany
info@probst-handling.de
www.probst-handling.com

Die vorstehend bezeichnete Maschine entspricht den einschlägigen Vorgaben nachfolgender EU-Richtlinien:
2006/42/EG (Maschinenrichtlinie)

Folgende Normen und technische Spezifikationen wurden herangezogen:

DIN EN ISO 12100

Sicherheit von Maschinen - Allgemeine Gestaltungsleitsätze - Risikobeurteilung und Risikominderung

DIN EN ISO 13857

Sicherheit von Maschinen - Sicherheitsabstände gegen das Erreichen von Gefährdungsbereichen mit den oberen und unteren Gliedmaßen

Dokumentationsbevollmächtigter:

Name: Jean Holderied
Anschrift: Probst GmbH; Gottlieb-Daimler-Straße 6; 71729 Erdmannhausen, Germany

Unterschrift, Angaben zum Unterzeichner:



Erdmannhausen, 30.05.2023.....
(Eric Wilhelm, Geschäftsführer)

2 Sicherheit

2.1 Sicherheitshinweise



Lebensgefahr!

Bezeichnet eine Gefahr. Wenn sie nicht gemieden wird, sind Tod und schwerste Verletzungen die Folge.



Gefährliche Situation!

Bezeichnet eine gefährliche Situation. Wenn sie nicht gemieden wird, können Verletzungen oder Sachschäden die Folge sein.



Verbot!

Bezeichnet ein Verbot. Wenn es nicht eingehalten wird, sind Tod und schwerste Verletzungen, oder Sachschäden die Folge.



Wichtige Informationen oder nützliche Tipps zum Gebrauch.

2.2 Begriffsdefinitionen

Greifbereich:	<ul style="list-style-type: none"> gibt die minimalen und maximalen Produktabmaße des Greifgutes an, welche mit diesem Gerät greifbar sind.
Greifgut (Greifgüter):	<ul style="list-style-type: none"> ist das Produkt, welches gegriffen bzw. transportiert wird.
Öffnungsweite:	<ul style="list-style-type: none"> setzt sich aus dem Greifbereich und dem Einfahrmaß zusammen. <i>Greifbereich + Einfahrmaß = Öffnungsbereich</i>
Eintauchtiefe:	<ul style="list-style-type: none"> entspricht der maximalen Greifhöhe von Greifgütern, bedingt durch die Höhe der Greifarme des Gerätes.
Gerät:	<ul style="list-style-type: none"> ist die Bezeichnung für das Greifgerät.
Produktmaß:	<ul style="list-style-type: none"> sind die Abmessungen des Greifgutes (z.B. Länge, Breite, Höhe eines Produktes).
Eigengewicht:	<ul style="list-style-type: none"> ist das Leergewicht (ohne Greifgut) des Gerätes.
Tragfähigkeit (WLL *):	<ul style="list-style-type: none"> gibt die höchstzulässige Belastung des Gerätes (zum Anheben von Greifgütern) an. * = WLL → (englisch:) <u>W</u>orking <u>L</u>oad <u>L</u>imit
Bodennaher Bereich:	<ul style="list-style-type: none"> das Greifgut muss unmittelbar nach dem Aufnehmen (z.B. von einer Palette oder von einem LKW) bis knapp über den Boden abgesenkt werden (ca. 0,5 m). Greifgut zum Transportieren nur so hoch wie nötig anheben (Empfehlung ca. 0,5 m über Boden).

2.3 Definition Fachpersonal/ Sachkundiger

Installations-, Wartungs-, und Reparaturarbeiten an diesem Gerät dürfen nur vom Fachpersonal oder Sachkundigen durchgeführt werden!

Fachpersonal oder Sachkundige müssen für die folgenden Bereiche, soweit es für dieses Gerät zutrifft, die notwendigen beruflichen Kenntnisse besitzen:

- für Mechanik
- für Hydraulik
- für Pneumatik
- für Elektrik

2.3.1 Erklärung der Piktogramme

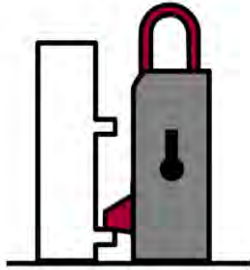

Wechselautomat geschlossen

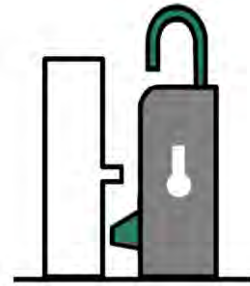

Wechselautomat offen

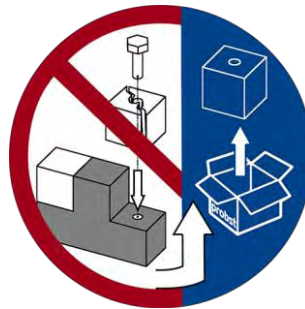

Beschädigte Zubehörteile nicht verwenden, gegebenenfalls ersetzen!



Gliedmaßen nicht unter die angehobene Last halten!
Verletzungsgefahr!



Erlaubte Anschlagmittel: Haken und Lasthebeband.





Lastsicherungskette (Zurrkette) darf nicht als Anschlagkette verwendet werden!
Die Lastsicherungskette kann reißen und die Last würde abstürzen!
Verletzungs- und Lebensgefahr!



Wenn die Last in die Lastsicherungskette fällt, muss die Kette fachgerecht geprüft und bei Bedarf ersetzt werden.
Beschädigte Lastsicherungskette nicht weiter einsetzen!

2.4 Sicherheitskennzeichnung



VERBOTSZEICHEN

Symbol	Bedeutung	Bestell-Nr.	Größe
	Niemals unter schwebende Last treten. Lebensgefahr!	29040210 29040209 29040204	Ø 30 mm Ø 50 mm Ø 80 mm
	Es dürfen keine konischen Greifgüter gegriffen werden.	29040213 29040212 29040211	Ø 30 mm Ø 50 mm Ø 80 mm
	Greifgüter niemals außermittig aufnehmen, stets im Lastschwerpunkt.	29040216 29040215 29040214	Ø 30 mm Ø 50 mm Ø 80 mm

WARNZEICHEN

Symbol	Bedeutung	Bestell-Nr.	Größe
	Quetschgefahr der Hände.	29040221 29040220 29040107	30 x 30 mm 50 x 50 mm 80 x 80 mm

GEBOTSZEICHEN

Symbol	Bedeutung	Bestell-Nr.	Größe
	Jeder Bediener muss die Bedienungsanleitung für das Gerät mit den Sicherheitsvorschriften gelesen und verstanden haben.	29040665 29040666 29041049	Ø 30 mm Ø 50 mm Ø 80 mm
	Das manuelle Führen des Gerätes ist nur an den roten Handgriffen erlaubt.	29040227 29040226 29040225	Ø 30 mm Ø 50 mm Ø 80 mm

OPTIONAL

	Einstecktasche und Gabelstaplerzinken mittels Arretierungsschraube und Sicherungskette oder Seil sichern.	29040223 29040222	Ø 50 mm Ø 80 mm
---	---	----------------------	--------------------

2.5 Persönliche Sicherheitsmaßnahmen



- Jeder Bediener muss die Bedienungsanleitung für das Gerät mit den Sicherheitsvorschriften gelesen und verstanden haben.
- Das Gerät und alle übergeordneten Geräte in/an die das Gerät eingebaut ist, dürfen nur von dafür beauftragten und qualifizierten Personen betrieben werden.



- Es dürfen **nur** Geräte **mit Handgriffen manuell** geführt werden.
Ansonsten besteht Verletzungsgefahr der Hände!

2.6 Schutzausrüstung

Die Schutzausrüstung besteht gemäß den sicherheitstechnischen Anforderungen aus:

- Schutzkleidung
- Schutzhandschuhe
- Sicherheitsschuhe

2.7 Unfallschutz



- Arbeitsbereich für unbefugte Personen, insbesondere Kinder, weiträumig absichern.
- **Vorsicht bei Gewitter – Gefahr durch Blitzschlag!**
Je nach Intensität des Gewitters gegebenenfalls die Arbeit mit dem Geräte einstellen.



- Arbeitsbereich ausreichend beleuchten.
- **Vorsicht bei nassen, angefrorenen, vereisten und verschmutzten Baustoffen!**
Es besteht die Gefahr des Herausrutschens des Greifgutes. → UNFALLGEFAHR!

2.8 Funktions- und Sichtprüfung

2.8.1 Mechanik



- Das Gerät muss vor jedem Arbeitseinsatz auf Funktion und Zustand geprüft werden.
- Wartung, Schmierung und Störungsbeseitigung dürfen nur bei stillgelegtem Gerät erfolgen!



- Bei Mängeln, die die Sicherheit betreffen, darf das Gerät erst nach einer kompletten Mängelbeseitigung wieder eingesetzt werden.
- Bei jeglichen Rissen, Spalten oder beschädigten Teilen an irgendwelchen Teilen des Gerätes, muss **sofort** jegliche Nutzung des Gerätes gestoppt werden.



- Die Betriebsanleitung für das Gerät muss am Einsatzort jederzeit einsehbar sein.
- Das am Gerät angebrachte Typenschild darf nicht entfernt werden.
- Unlesbare Hinweisschilder (wie Verbots- und Warnzeichen) sind auszutauschen.

2.9 Sicherheit im Betrieb

2.9.1 Allgemeines



- Die Arbeit mit dem Gerät darf nur in bodennahem Bereich erfolgen. Das Schwenken des Gerätes über Personen hinweg ist untersagt.
- Der Aufenthalt unter schwebender Last ist verboten. **Lebensgefahr!**



- Das manuelle Führen ist nur bei Geräten mit Handgriffen erlaubt.



- Während des Betriebes ist der Aufenthalt von Personen im Arbeitsbereich verboten! Es sei denn es ist unerlässlich, bedingt durch die Art der Geräteanwendung, z.B. durch manuelles Führen des Gerätes (an Handgriffen).
- Ruckartiges Anheben oder Absenken des Gerätes mit und ohne Last ist **verboten**, sowie das schnelle Fahren mit dem Trägergerät/ Hebezeug über unebenes Gelände! Generell darf mit angehobener Last mit dem Trägergerät/Hebezeug (z.B. Bagger) **nur** mit **Schrittgeschwindigkeit** gefahren werden - unnötige Erschütterungen sind zu vermeiden. **Gefahr:** Last könnte herabfallen oder Lastaufnahmemittel beschädigt werden!



- Die Güter niemals außermittig aufnehmen (stets im Lastschwerpunkt), ansonsten Kippgefahr.
- Das Gerät darf nicht geöffnet werden, wenn der Öffnungsweg durch einen Widerstand blockiert ist.
- Die Tragfähigkeit und Nennweiten des Gerätes dürfen nicht überschritten werden.
- Der Bediener darf den Steuerplatz nicht verlassen, solange das Gerät mit Ladung belastet ist und muss die Ladung immer im Blick haben.



- Festsitzende Lasten nicht mit dem Gerät losreißen.
- Lasten niemals schräg ziehen oder schleifen. Ansonsten könnten dadurch Teile des Gerätes beschädigt werden (siehe Abb. A →).



Abb. A

2.9.2 Trägergeräte / Hebezeuge



- Das eingesetzte Trägergerät / Hebezeug (z.B. Bagger) muss sich in betriebssicherem Zustand befinden.
- Nur beauftragte und qualifizierte Personen dürfen das Trägergerät / Hebezeug bedienen.
- Der Bediener des Trägergerätes / Hebezeuges muss die gesetzlich vorgeschriebenen Qualifikationen erfüllen.

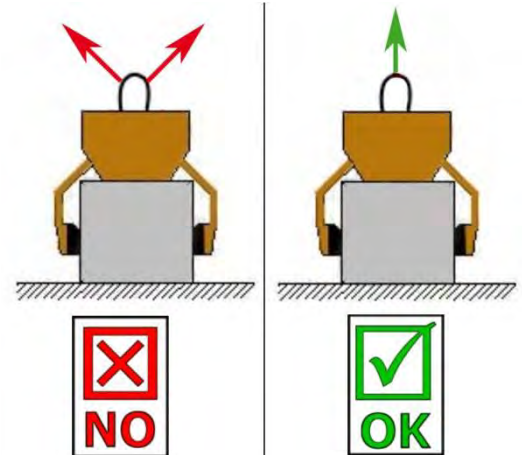

Die maximal erlaubte Traglast des Trägergerätes / Hebezeuges und der Anschlagmittel darf unter keinen Umständen überschritten werden!

3 Allgemeines

3.1 Bestimmungsgemäßer Einsatz

Das Gerät TSZ-UNI ist ausschließlich geeignet zum Greifen, Transportieren und Ablegen von Greifgütern wie Trittstufen, Bordsteine, Randwinkel und L-Steine. Mit dem optionalen Zubehör „Stahlgreifpratzen WB-SQ“ lassen sich auch roh behauene Steinquader greifen.

Das Gerät wird mit einem entsprechenden Hebezeug/Trägergerät (z.B. Bagger) eingesetzt.



- Das Gerät darf nur für den in der Bedienungsanleitung beschriebenen bestimmungsgemäßen Einsatz, unter Einhaltung der gültigen Sicherheitsvorschriften und unter Einhaltung der dementsprechenden gesetzlichen Bestimmungen und den der Konformitätserklärung verwendet werden.
- Jeder anderweitige Einsatz gilt als nicht bestimmungsgemäß und ist **verboten!**
- Die am Einsatzort gültigen gesetzlichen Sicherheits- und Unfallvorschriften müssen zusätzlich eingehalten werden.



Der Anwender **muss** sich vor jedem Einsatz vergewissern, dass:

- das Gerät für den vorgesehenen Einsatz geeignet ist
- sich im ordnungsgemäßen Zustand befindet
- die zu hebenden Lasten für das Heben geeignet sind

In Zweifelsfällen setzen Sie sich vor der Inbetriebnahme mit dem Hersteller in Verbindung.



ACHTUNG: Das Arbeiten mit diesem Gerät darf nur in bodennahem Bereich erfolgen! (→ Kapitel „Sicherheit im Betrieb“ und „Begriffsdefinitionen“)



Es dürfen **nur** Steinelemente mit parallelen und ebenen Greifflächen gegriffen werden!
Ansonsten besteht **Abrutschgefahr!**



NICHT ERLAUBTE TÄTIGKEITEN:

Eigenmächtige Umbauten am Gerät oder der Einsatz von eventuell selbstgebauten Zusatzvorrichtungen gefährden Leib und Leben und sind deshalb grundsätzlich **verboten!!**

Tragfähigkeiten (WLL) des Gerätes dürfen **nicht überschritten** und **Nennweiten/Greifbereiche** dürfen **nicht überschritten bzw. unterschritten** werden.

Alle nicht bestimmungsgemäßen Transporte mit dem Gerät sind **strengstens untersagt**:

- das Transportieren von Menschen und Tieren.
- das Greifen und Transportieren von Baustoffpaketen, Gegenständen und Materialien, die nicht in dieser Betriebsanleitung beschrieben sind.
- das Anhängen von Lasten mit Seilen, Ketten o.ä. an dem Gerät, außer an den dafür vorgesehenen Einhängeösen/-bolzen.
- das Greifen von Greifgütern mit Verpackungsfolie, da dabei **Abgleitgefahr** besteht.
- das Greifen von Greifgütern mit Reibbeiwert mindernder Oberfläche (z.B. abmehlende, behandelte, verschmutzte, angefrorene, beschichtete, lackierte Oberflächen), da dies zur Verminderung des Reibwertes zwischen Greifbacken und Greifgut führt → **Abgleitgefahr!**
Abhilfe: Bei Verschmutzung jeglicher Art ist zwingend eine Reinigung der Greifbacken und Oberfläche der Produkte im Bereich der Greifbacken **vor jedem** Greifvorgang erforderlich!
- das Greifen von Greifgütern, welche sich durch die Klemmkraft des Greifgerätes verformen oder brechen können!
- das Greifen von Greifgütern, welche sichtbare Beschädigungen aufweisen oder durch ihr Eigengewicht brechen können.
- das Greifen und Transportieren von konischen und runden Greifgütern, da dabei Abgleitgefahr besteht. (Abbildung rechts)
- Steinlagen, die „Füße“, „Bäuche“ oder „blinde Abstandshalter“ haben.

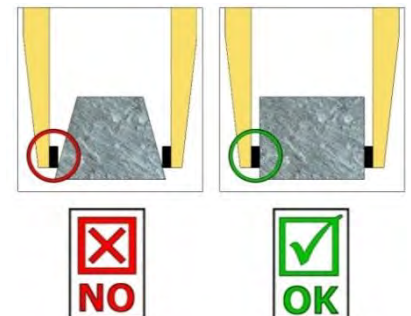

3.2 Übersicht und Aufbau

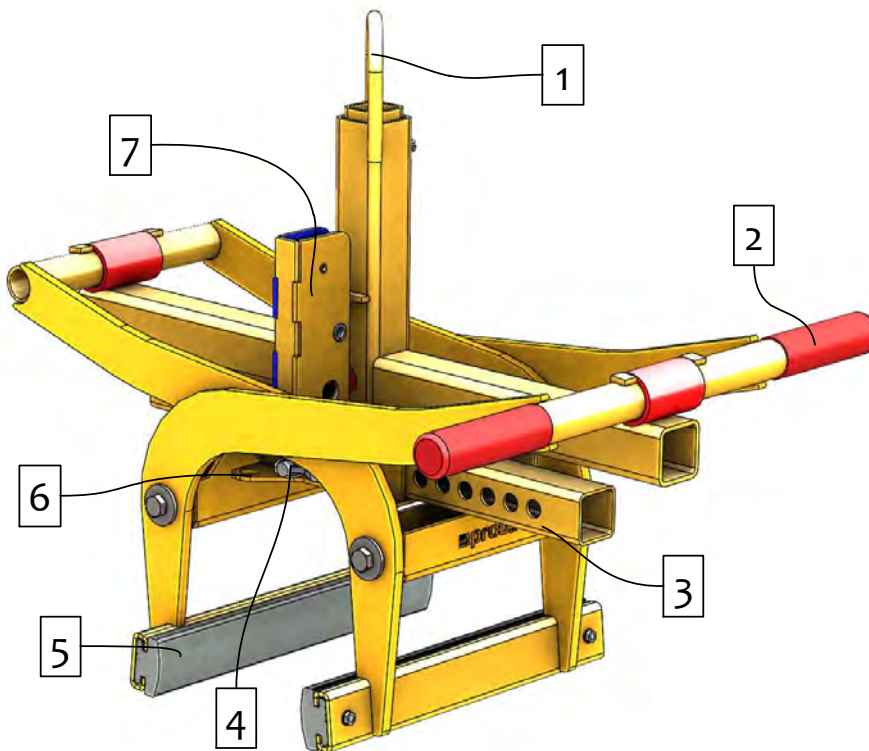

1. Einhängeöse für Kranhaken
2. Handgriff zur Führung des Gerätes
3. Verstellung Greifbereich
4. Federriegel zur Greifbereichsverstellung
5. Gummigreifbacke (auswechselbar)
6. Montageplatte für HVA
7. Wechselautomat zum vollautomatischen Umschalten von "Greifen" auf "Lösen"

3.3 Zubehör

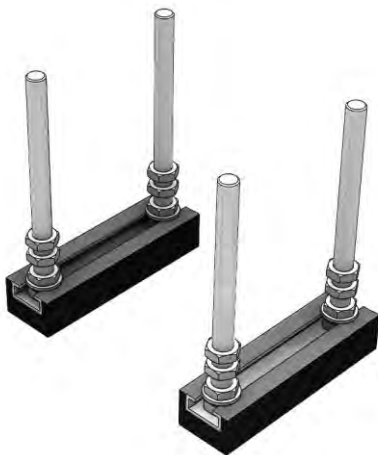

HVA-FTZ/TSZ
Verlegen im Stapelbetrieb

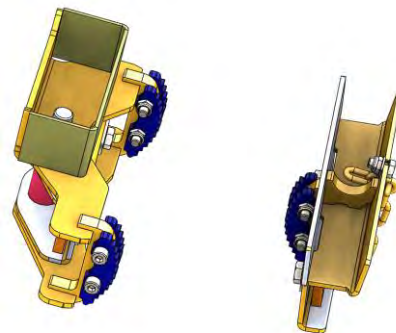

TSZ-UNI-WB-SQ
Greifen von roh behauenen Steinen

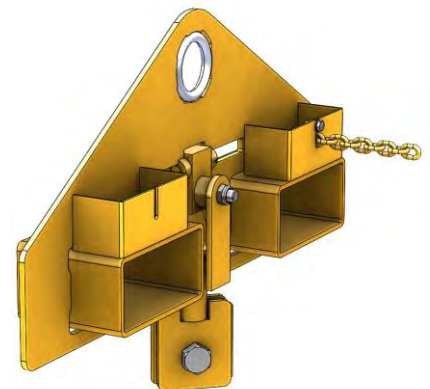

TSZ-UNI-ET
Einstecktasche

3.4 Technische Daten

Die genauen technischen Daten (wie z.B. Tragfähigkeit, Eigengewicht, etc.) sind dem Typenschild zu entnehmen.

4 Installation

4.1 Mechanischer Anbau

Nur Original-Probst-Zubehör verwenden, im Zweifelsfall Rücksprache mit dem Hersteller halten.



Die **Tragfähigkeit** des Trägergerätes/Hebezeuges darf durch die Last des Gerätes, der optionalen Anbaugeräte (Drehmotor, Einstecktasche, Kranausleger etc.) und die zusätzliche Last der Greifgüter **nicht überschritten** werden!

Greifgeräte müssen **immer kardanisch** aufgehängt werden, so dass sie in jeder Position frei auspendeln können.



Auf **keinen** Fall dürfen die Greifgeräte auf **starre** Weise mit dem Hebezeug/Trägergerät verbunden werden!

Es kann in kurzer Zeit zum Bruch der Aufhängung führen. Tod, schwerste Verletzungen und Sachschaden können die Folge sein!



Bei Verwendung des Gerätes an optionalen Anbaugeräten (wie Einstecktasche, Kranausleger etc.) ist es aufgrund der möglichst niedrigen Bauweise des Gesamtgerätes (zur Vermeidung von Hubhöhenverlust) nicht auszuschließen, dass bei pendelnder Aufhängung des Gerätes und ungünstiger Positionierung bei Fahrbewegungen des Trägergerätes, das Gerät mit angrenzenden Bauteilen zusammenstoßen kann. Dies ist durch geeignete Positionierung des Gerätes und angepasster Fahrweise möglichst zu vermeiden. Daraus resultierende Schäden werden nicht im Rahmen der Gewährleistung reguliert.

4.1.1 Einhängeöse / Einhängebolzen

Das Gerät ist mit einer Einhängeöse / Einhängebolzen ausgerüstet und kann somit an verschiedenste Trägergeräte/Hebezeuge angebracht werden.



Es ist darauf zu achten, dass die Einhängeöse / Einhängebolzen sicher mit dem Anschlagmittel (Kranhaken, Schlupf etc.) verbunden ist und nicht abrutschen kann.

4.1.2 Lasthaken und Anschlagmittel



Das Gerät wird mit einem Lasthaken oder einem geeigneten Anschlagmittel am Trägergerät/Hebezeug angebracht.

Es ist darauf zu achten, dass die einzelnen Kettenstränge nicht verdreht oder verknotet sind.

Bei der mechanischen Installation des Gerätes ist darauf zu achten, dass alle örtlich geltenden Sicherheitsvorschriften eingehalten werden.

4.1.3 Drehköpfe (optional)



Beim Einsatz von Drehköpfen **muss** zwingend eine **Freilaufdrossel** verbaut sein.

Damit ein stoßartiges Beschleunigen und Stoppen der Drehbewegungen ausgeschlossen wird, da diese sonst das Gerät innerhalb kurzer Zeit **beschädigen** können.

4.1.4 Einstecktaschen (optional)



Um eine sichere Verbindung zwischen dem Gabelstapler und der Einstecktasche (3) herzustellen, fährt man mit den Gabelstapler-Zinken (1) in die Einstecktasche (3) hinein.

Danach arretiert man diese entweder mittels Arretierungsschrauben (2), welche durch eine vorzusehende Bohrung in die Stapler-Zinken (1) gesteckt wird, oder mittels einer Kette oder eines Seils (4), das durch die Ösen an den Einstecktasche (3) und um den Gabelträger (↘) gelegt werden muss.



Diese Verbindung **muss** hergestellt werden, da sonst die Einstecktasche beim Staplerbetrieb von den Gabelstapler-Zinken rutschen kann. **UNFALLGEFAHR!**

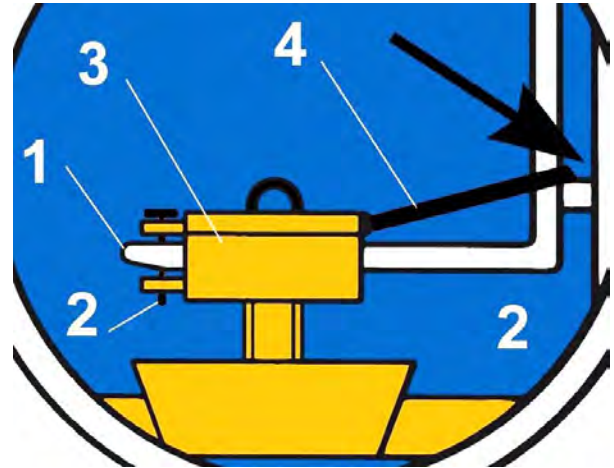
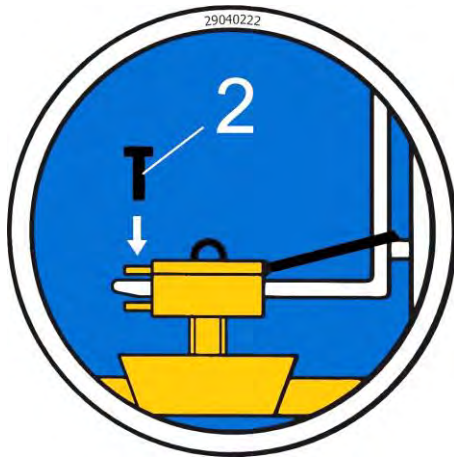

4.2 Installation der Stahlgreifpratzen WB-SQ

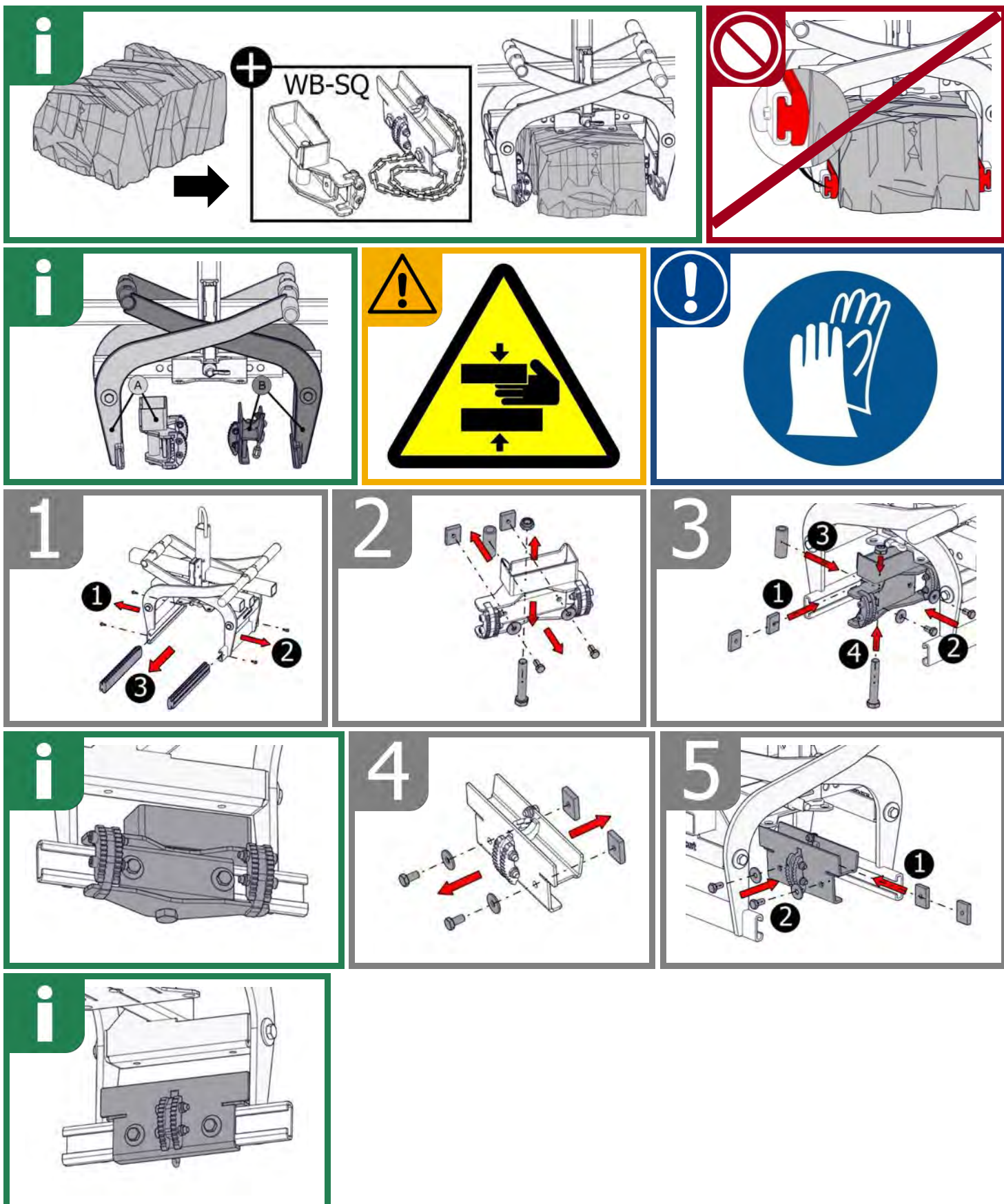

5 Einstellungen

5.1 Einstellung des Greifbereichs

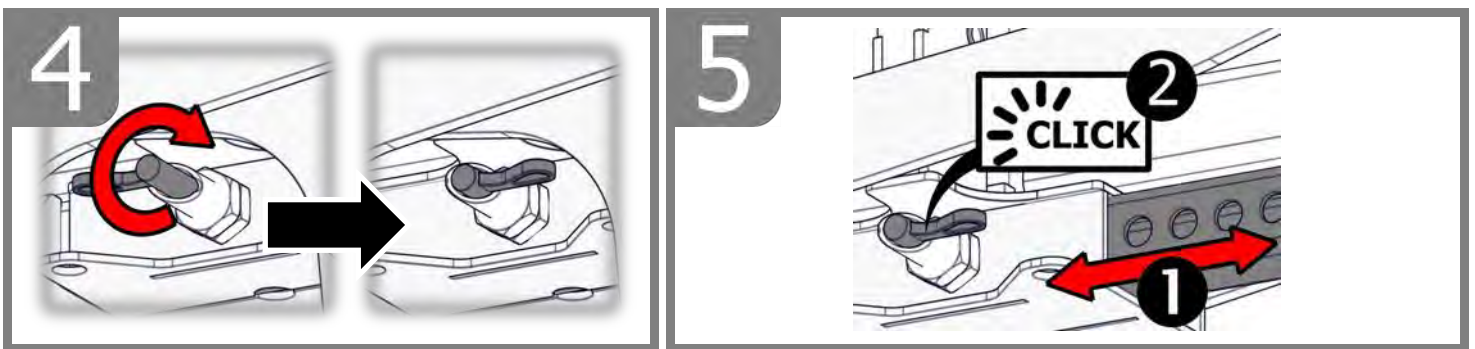
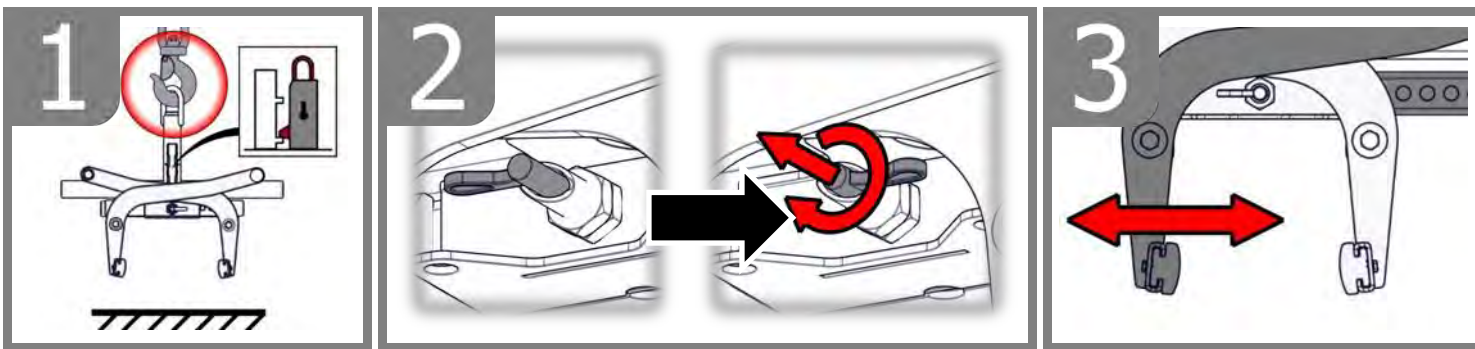
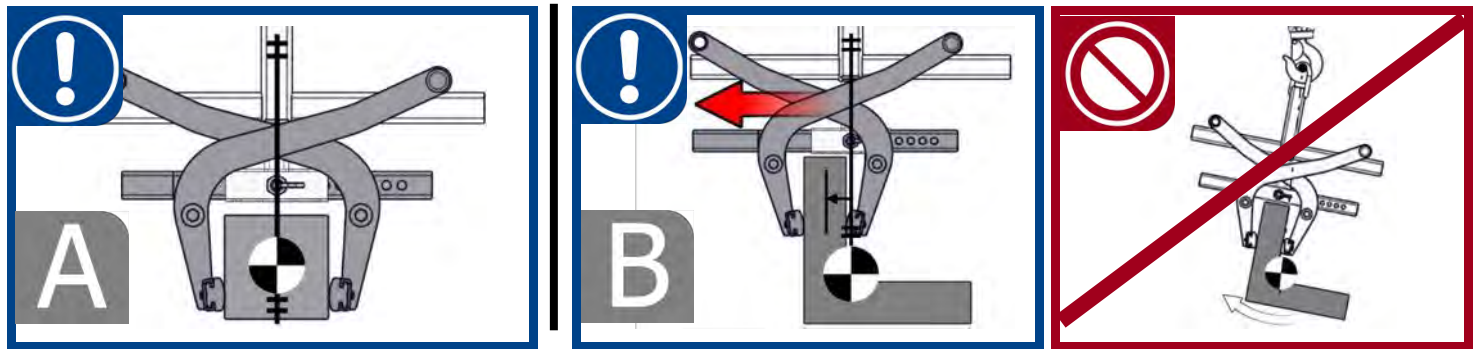
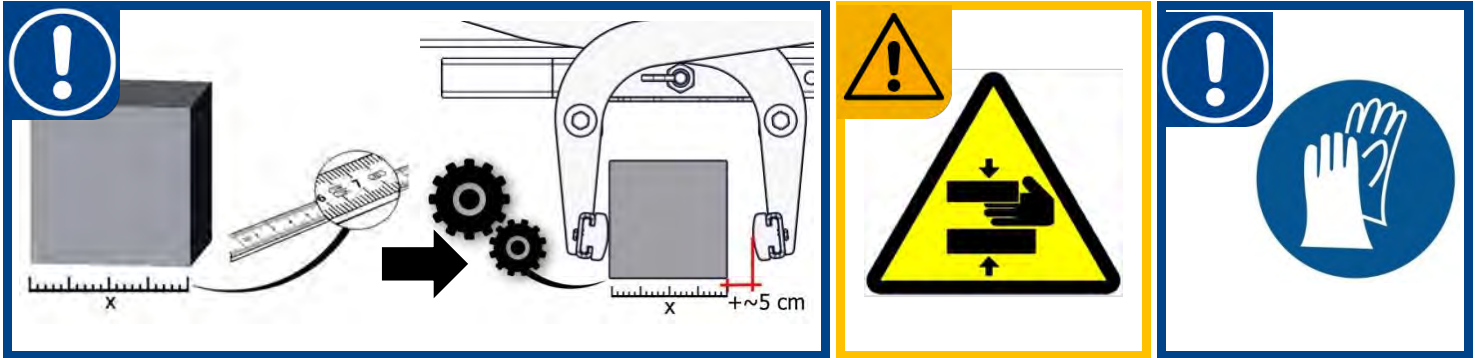

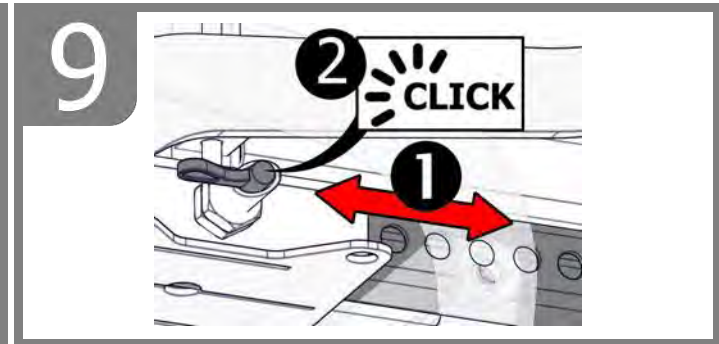
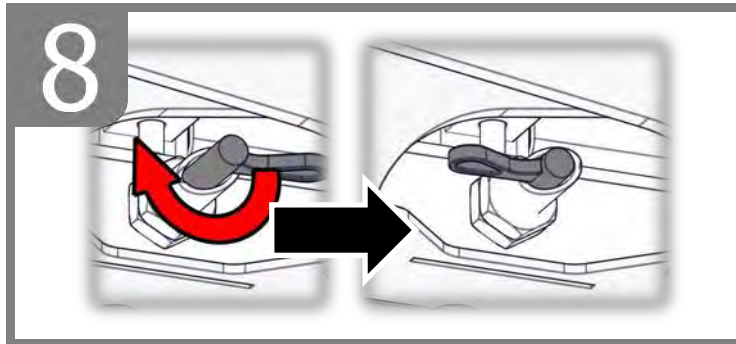
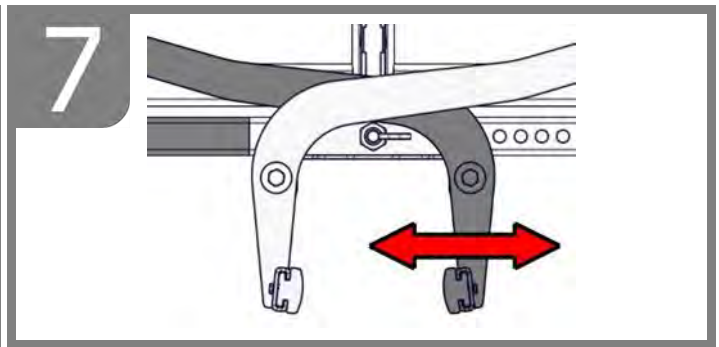
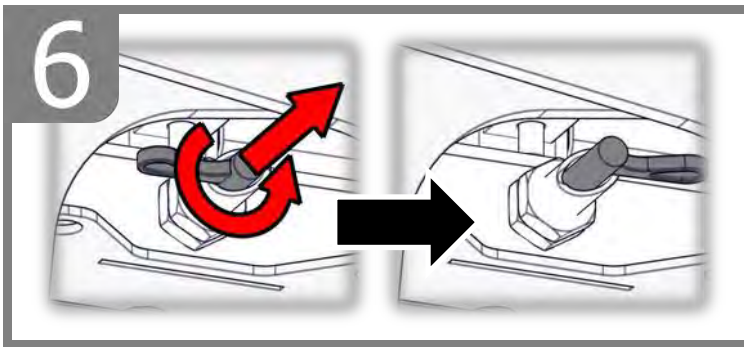

5.2 Zubehör – HVA für Stapelbetrieb

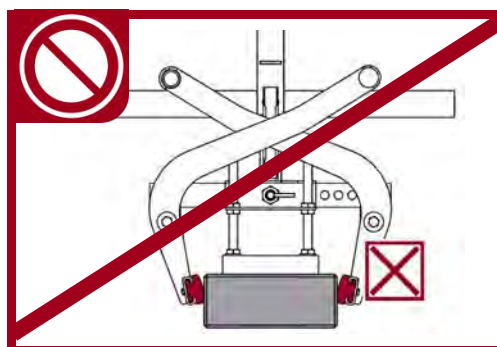
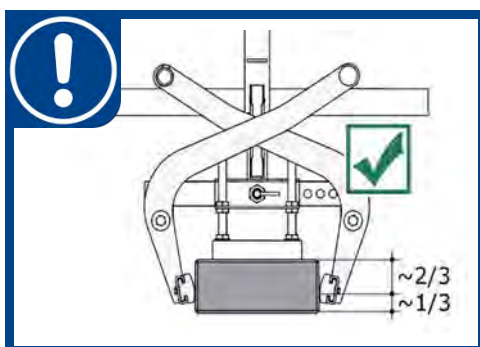
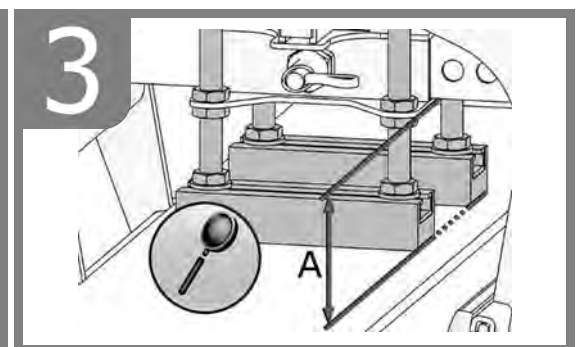
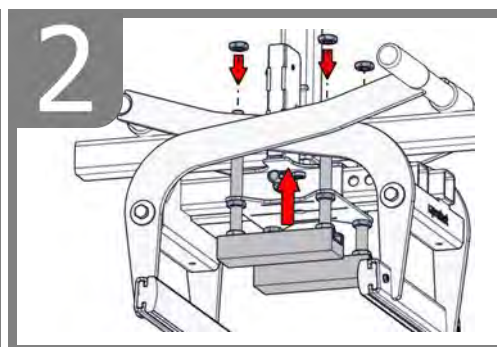
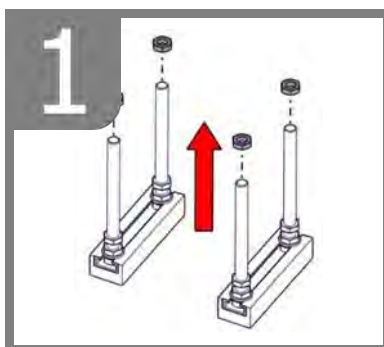
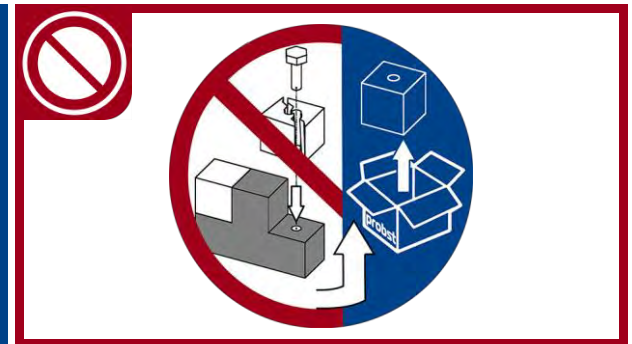
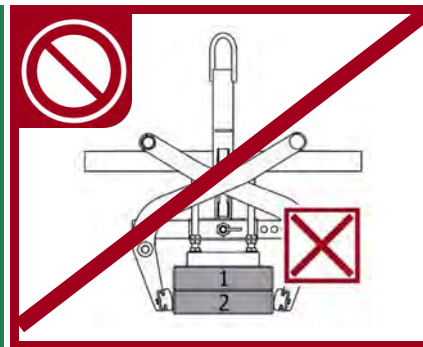
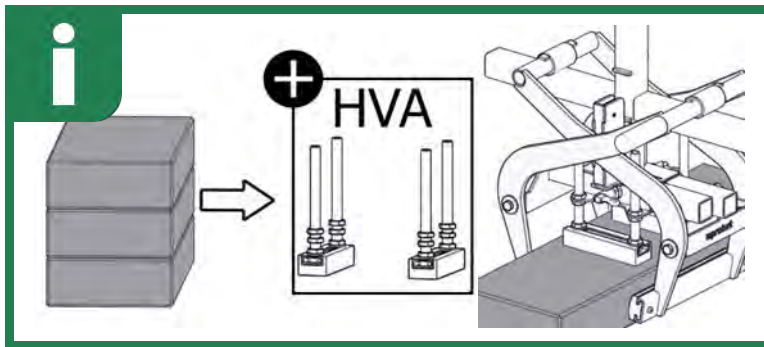

6 Bedienung

6.1 Greifen, Versetzen und Ablegen von Lasten

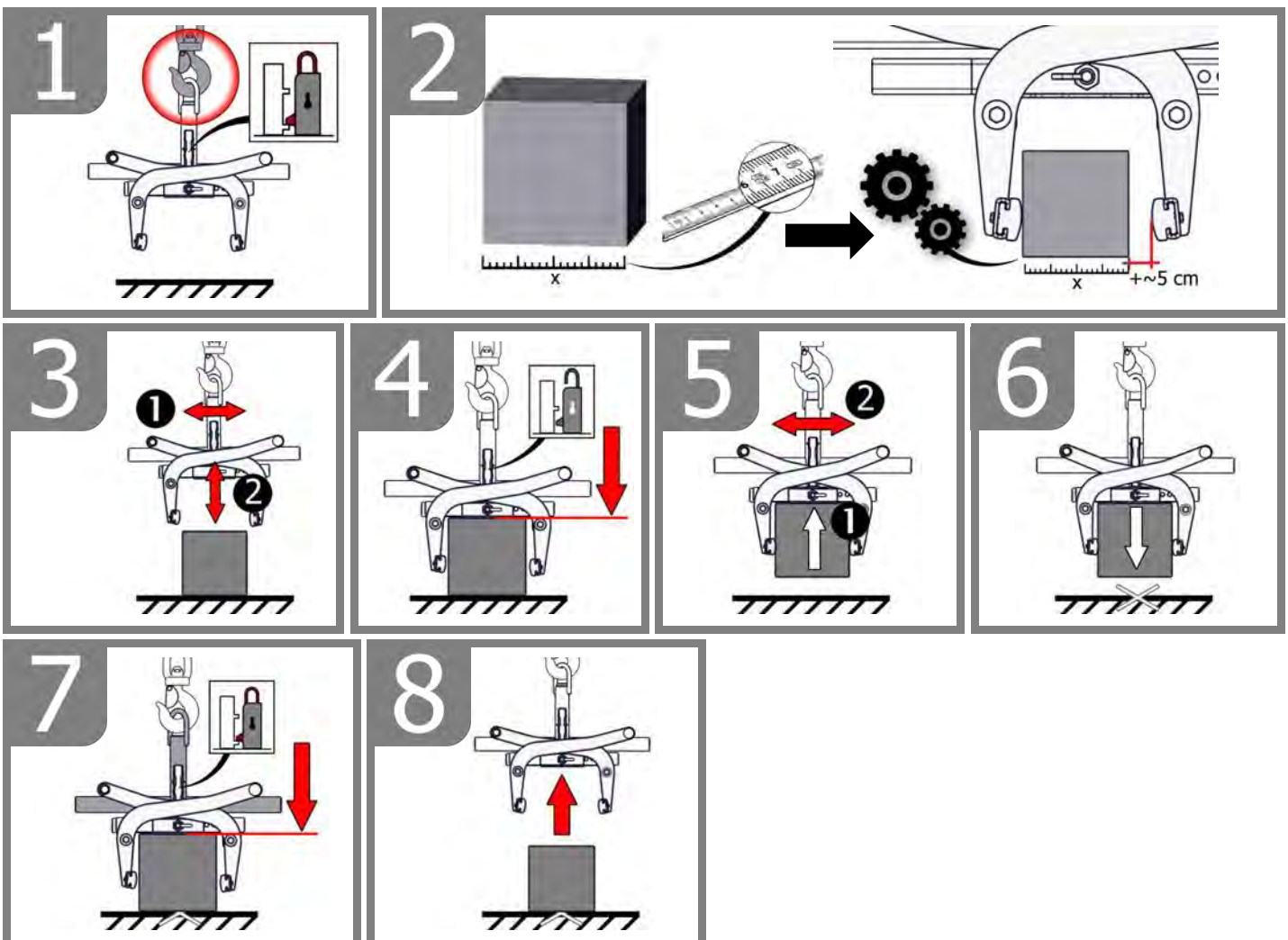

6.2 Darstellung der Wechselautomatik

Das Gerät ist mit einer Wechselautomatik ausgerüstet, das heißt das ÖFFNEN und SCHLIESSEN der Greifarme erfolgt durch das Absetzen und Anheben des Gerätes.

Bildliche Darstellungen der Schaltpositionen der Wechselautomatik:

<p>1</p> <ul style="list-style-type: none"> • Gerät ist durch das Trägergerät angehoben • Greifarme sind geöffnet 	<p>2</p> <ul style="list-style-type: none"> • Gerät wird auf das Greifgut abgesetzt • Greifarme sind geöffnet 	<p>3A</p> <ul style="list-style-type: none"> • Gerät wird durch das Trägergerät angehoben • Greifgut ist gespannt und kann nun zum Bestimmungsort transportiert werden
<p>3B</p> <ul style="list-style-type: none"> • Bei Fehlschaltung muss der Umschalter manuell (z.B. mit Schraubendreher) wieder zurück gedrückt werden ¹⁾ 	<p>4</p> <ul style="list-style-type: none"> • Gerät ist mit dem Greifgut auf Boden abgesetzt • Greifarme werden geöffnet 	<p>5/1</p> <ul style="list-style-type: none"> • Gerät ist durch das Trägergerät angehoben • Greifarme sind geöffnet (Abstellposition des Gerätes auf Boden)



1) Sonst kann es zu Fehlschaltungen und dann beim Absetzen der Last zur Verformung oder Zerstörung der Wechselautomatik kommen.

Ruckartiges Anheben oder Absenken des Gerätes, sowie auch schnelles Fahren mit dem Trägergerät/ Hebezeug über unebenes Gelände ist verboten!



Beim Auswechseln einer defekten Wechselautomatik ist unbedingt darauf zu achten, dass die Schlitze der beiden Spannstifte immer nach unten zeigen.

Die Position der Schlitze darf sich keinesfalls oben oder in der Mitte befinden, da sonst die Gefahr besteht, dass die Wechselautomatik beim Umschalten klemmt!

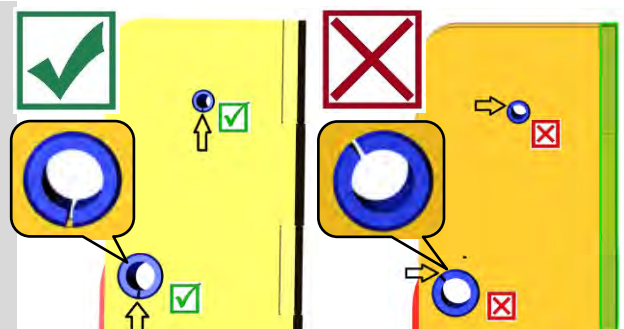

6.3 Bedienung: Stahlgreifprätzen WB-SQ

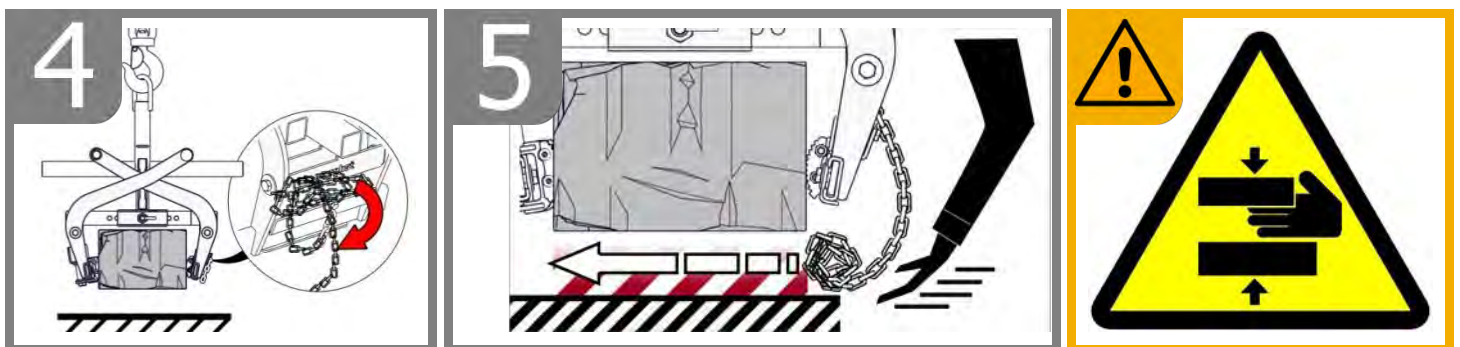
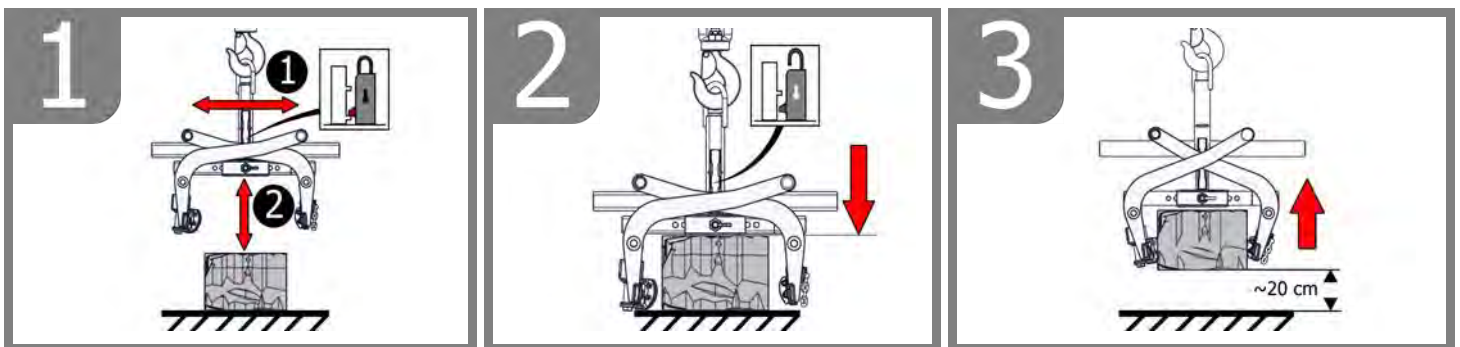
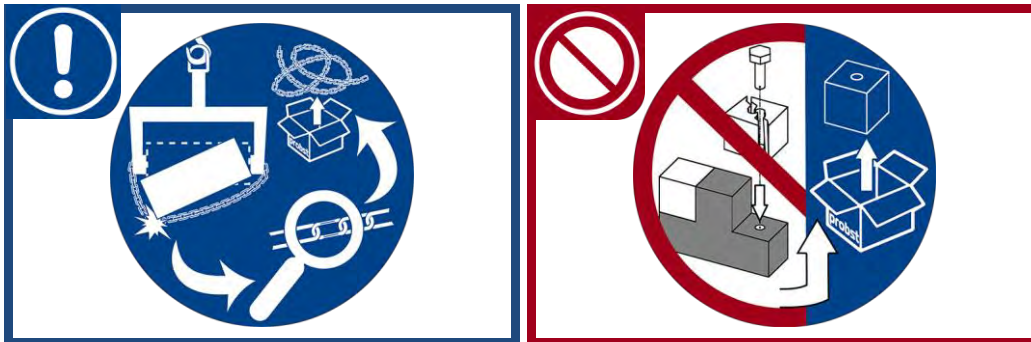
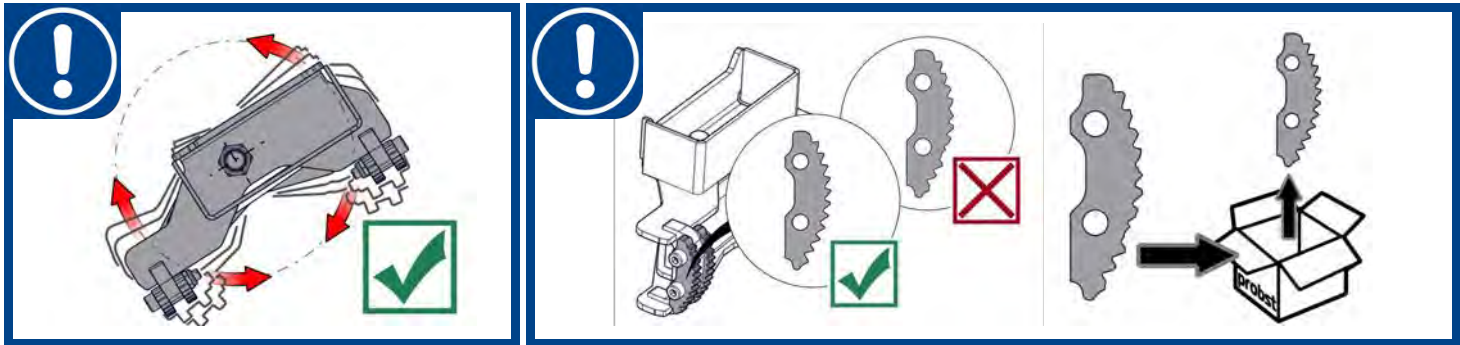

7 Wartung und Pflege

7.1 Wartung



Um eine einwandfreie Funktion, Betriebssicherheit und Lebensdauer des Gerätes zu gewährleisten, sind die in der unteren Tabelle aufgeführten Wartungsarbeiten nach Ablauf der angegebenen Fristen durchzuführen.

Es dürfen **nur Original-Ersatzteile** verwendet werden, ansonsten erlischt die Gewährleistung.



Alle Arbeiten dürfen nur bei stillgelegtem Gerät erfolgen!

Bei allen Arbeiten muss sichergestellt sein, dass sich das Gerät nicht unabsichtlich schließen kann.

Verletzungsgefahr!

7.1.1 Mechanik

WARTUNGSFRIST	Auszuführende Arbeiten
Erstinspektion nach 25 Betriebsstunden	<ul style="list-style-type: none"> Sämtliche Befestigungsschrauben kontrollieren bzw. nachziehen (darf nur von einem Sachkundigen durchgeführt werden).
Alle 50 Betriebsstunden	<ul style="list-style-type: none"> Sämtliche Befestigungsschrauben nachziehen (achten Sie darauf, dass die Schrauben gemäß den gültigen Anzugsdrehmomenten der zugehörigen Festigkeitsklassen nachgezogen werden). Sämtliche vorhandene Sicherungselemente (wie Klappsplinte) auf einwandfreie Funktion prüfen und defekte Sicherungselemente ersetzen. → 1) Alle Gelenke, Führungen, Bolzen und Zahnräder, Ketten auf einwandfreie Funktion prüfen, bei Bedarf nachstellen oder ersetzen. Greifbacken (sofern vorhanden) auf Verschleiß prüfen und reinigen, bei Bedarf ersetzen. Alle vorhandenen Gleitführungen, Zahnstangen, Gelenke von beweglichen Bauteilen oder Maschinenbaukomponenten sind zur Reduzierung von Verschleiß und für optimale Bewegungsabläufe einzufetten/ zu schmieren (empfohlenes Schmierfett: <i>Mobilgrease HXP 462</i>). Alle Schmiernippel (sofern vorhanden) mit Fettpresse schmieren.
Mindestens 1x pro Jahr (bei harten Einsatzbedingungen Prüfintervall verkürzen)	<ul style="list-style-type: none"> Kontrolle aller Aufhängungsteile, sowie Bolzen und Laschen. Prüfung auf Risse, Verschleiß, Korrosion und Funktionssicherheit durch einen Sachkundigen.

1)

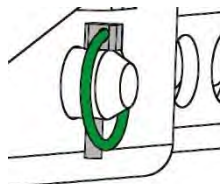

Gummigreifbacken



Regelmäßige Kontrolle auf **Schmutz** (z.B. kleine Steinpartikel) im oberen Bereich (siehe Punkte Bildausschnitt „X“ in Abb. 2) der Gummigreifbacken (6) → siehe Abb. 1 / Abb. 2.

Problem: Schmutz kann die Gummigreifbacken (6) beim Greifvorgang in diesem Bereich beschädigen (indem sich Steinpartikel in den Gummi drücken).

Abhilfe: Schmutz in diesem Bereich an Gummigreifbacken (6) entfernen, bzw. bei starker Verschmutzung Gummigreifbacken demontieren und reinigen.



Abb. 1



Abb. 2

7.1.2 Zusätzlich bei Stahlgreifpratzen (WB-SQ)

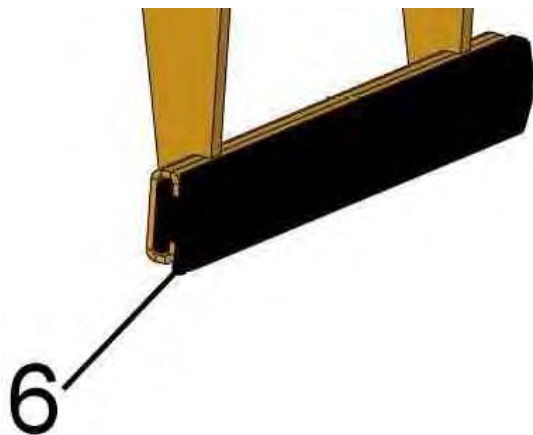
Vor jeder Inbetriebnahme	<ul style="list-style-type: none"> Stahlgreifpratzen auf Beweglichkeit, Verschleiß und Verschmutzung prüfen. Abgenutzte (nicht mehr scharfkantige) oder verbogene Stahlgreifpratzen müssen erneuert werden!
Regelmäßig	<ul style="list-style-type: none"> Reinigung des Gerätes mit Hochdruckreiniger (Warmwasser).
Wöchentlich	<ul style="list-style-type: none"> Bewegliche Teile schmieren und ölen.

WECHSELAUTOMATIK

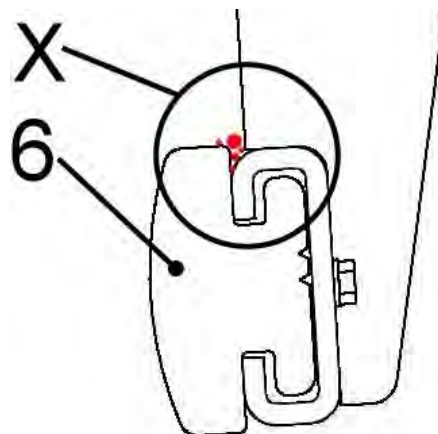

Die Wechsellautomatik darf **niemals** mit Fett oder Öl geschmiert werden!
Bei sichtbarer Verschmutzung mit Hochdruckreiniger reinigen!

7.2 Störungsbeseitigung

STÖRUNG	URSACHE	BEHEBUNG
Die Klemmkraft ist nicht ausreichend, die Last rutscht ab		
(optional)	Die Greifbacken sind abgenutzt	Greifbacken erneuern
(optional)	Traglast ist größer als zulässig	Traglast reduzieren
Greifbereichs-Einstellung (optional)	Es ist der falsche Greifbereich eingestellt	Greifbereich entsprechend auf die zu transportierenden Güter einstellen
(Material-Eigenschaften)	Die Materialoberfläche ist verschmutzt oder der Baustoff ist nicht für dieses Gerät geeignet/ zulässig	Materialoberfläche prüfen oder Rücksprache mit Hersteller, ob Baustoff für dieses Gerät zulässig ist
Das Gerät hängt schief		
	Die Zange ist einseitig belastet	Last symmetrisch verteilen
Greifbereichs -Einstellung (optional)	Der Greifbereich ist nicht symmetrisch eingestellt	Einstellung des Greifbereichs prüfen und korrigieren
Wechselautomatik funktioniert nicht		
Mechanik	Wechselautomatik funktioniert nicht	Wechselautomatik mit Hochdruckreiniger reinigen Fehlschaltung korrigieren (→ siehe Kapitel „Darstellung der Wechselautomatik“) Einsatz der Wechselautomatik austauschen

7.3 Reparaturen



- Reparaturen am Gerät dürfen nur von Personen durchgeführt werden, die die dafür notwendigen Kenntnisse und Fähigkeiten besitzen.
- Vor der Wiederinbetriebnahme muss eine außerordentliche Prüfung durch einen Sachverständigen durchgeführt werden.

7.4 Prüfungspflicht



- Der Unternehmer hat dafür zu sorgen, dass das Gerät mindestens jährlich durch einen Sachkundigen geprüft und festgestellte Mängel sofort beseitigt werden (→ DGUV Regel 100-500).
- Die dementsprechenden gesetzlichen Bestimmungen u. die der Konformitätserklärung sind zu beachten!
- Die Durchführung der Sachkundigenprüfung kann auch durch den Hersteller Probst GmbH erfolgen. Kontaktieren Sie uns unter: service@probst-handling.de
- Wir empfehlen, nach durchgeführter Prüfung und Mängelbeseitigung des Gerätes die Prüfplakette „Sachkundigenprüfung/ Expert inspection“ gut sichtbar anzubringen (Bestell-Nr.: 29040056+Tüv-Aufkleber mit Jahreszahl).



Die Sachkundigenprüfung ist unbedingt zu dokumentieren!

Gerät	Jahr	Datum	Sachkundiger	Firma

7.5 Hinweis zum Typenschild



- Gerätetyp, Gerätenummer und Baujahr sind wichtige Angaben zur Identifikation des Gerätes. Sie sind bei Ersatzteilbestellungen, Gewährleistungsansprüchen und sonstigen Anfragen zum Gerät stets mit anzugeben.
- Die maximale Tragfähigkeit (WLL) gibt an, für welche maximale Belastung das Gerät ausgelegt ist. Die maximale Tragfähigkeit (WLL) darf **nicht** überschritten werden.
- Das im Typenschild bezeichnete Eigengewicht ist bei der Verwendung am Hebezeug/Trägergerät (z.B. Kran, Kettenzug, Gabelstapler, Bagger...) mit zu berücksichtigen.

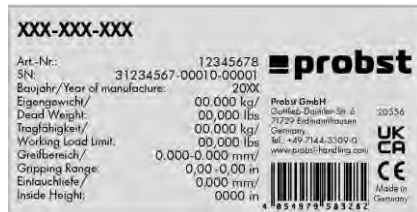

Beispiel:

7.6 Hinweis zur Vermietung/Verleihung von PROBST-Geräten



Bei jeder Verleihung/Vermietung von PROBST-Geräten **muss** unbedingt die dazu gehörige **Original-Betriebsanleitung** mitgeliefert werden (bei Abweichung der Sprache des jeweiligen Benutzerlandes, ist zusätzlich die jeweilige Übersetzung der Original-Betriebsanleitung mit zuliefern)!

8 Entsorgung / Recycling von Geräten und Maschinen



Das Produkt **darf nur** von qualifiziertem Fachpersonal außer Betrieb genommen und zur Entsorgung/ zum Recyceln vorbereitet werden. Entsprechend vorhandene **Einzelkomponenten** (wie Metalle, Kunststoffe, Flüssigkeiten, Batterien/Akkus etc.) **müssen** gemäß den **national/ länderspezifisch geltenden Gesetzen und Entsorgungsvorschriften** entsorgt/recycelt werden!



Das Produkt darf nicht im Hausmüll entsorgt werden!

Wartungsnachweis



Garantieanspruch für dieses Gerät besteht nur bei Durchführung der vorgeschriebenen Wartungsarbeiten (durch eine autorisierte Fachwerkstatt)! Nach jeder erfolgten Durchführung eines Wartungsintervalls muss unverzüglich dieser Wartungsnachweis (mit Unterschrift u. Stempel) an uns übermittelt werden. ¹⁾

¹⁾ per E-Mail an: service@probst-handling.de / per Fax oder Post

Betreiber: _____
 Gerätetyp: _____ Artikel-Nr.: _____
 Geräte-Nr.: _____ Baujahr: _____

Wartungsarbeiten nach 25 Betriebsstunden		
Datum:	Art der Wartung:	Wartung durch Firma:
		Stempel
	
		Name / Unterschrift

Wartungsarbeiten nach 50 Betriebsstunden		
Datum:	Art der Wartung:	Wartung durch Firma:
		Stempel
	
		Name / Unterschrift
		Wartung durch Firma:
		Stempel
	
		Name / Unterschrift
		Wartung durch Firma:
		Stempel
	
		Name / Unterschrift

Wartungsarbeiten 1x jährlich		
Datum:	Art der Wartung:	Wartung durch Firma:
		Stempel
	
		Name / Unterschrift
		Wartung durch Firma:
		Stempel
	
		Name / Unterschrift

DE

TSZ-UNI



GB | Operating Instructions



Bitte beachten Sie, dass das Produkt ohne vorliegende Betriebsanleitung in Landessprache nicht eingesetzt / in Betrieb gesetzt werden darf. Sollten Sie mit der Lieferung des Produkts keine Betriebsanleitung in Ihrer Landessprache erhalten haben, kontaktieren Sie uns bitte. In Länder der EU / EFTA senden wir Ihnen diese kostenlos nach. Für Länder außerhalb der EU / EFTA erstellen wir Ihnen gerne ein Angebot für eine Betriebsanleitung in Landessprache, falls die Übersetzung nicht durch den Händler/Importeur organisiert werden kann.

Please note that the product may not be used / put into operation without these operating instructions in the national language. If you did not receive operating instructions in your national language with the delivery of the product, please contact us. In countries of the EU / EFTA we will send them to you free of charge. For countries outside the EU / EFTA, we will be pleased to provide you with an offer for an operating manual in the national language if the translation cannot be organised by the dealer/importer.

Contents

1	EC-Declaration of Conformity / UKCA-Declaration of Conformity	3
2	Safety	4
2.1	Safety symbols	4
2.2	Explanation of basic concepts	4
2.3	Definition skilled worker / specialist	4
2.3.1	Explanation of the pictograms	5
2.4	Safety Marking	6
2.5	Personal safety requirements	7
2.6	Protective equipment	7
2.7	Accident prevention	7
2.8	Function Control	7
2.8.1	General	7
2.9	Safety procedures	8
2.9.1	General	8
2.9.2	Carrier / Lifting device	8
3	General	9
3.1	Authorized use	9
3.2	Survey and construction	11
3.3	Accessoires	11
3.4	Technical data	11
4	Installation	12
4.1	Mechanical connection	12
4.1.1	Lifting eye / Suspension bolt	12
4.1.2	Load hooks and lifting tackle	12
4.1.3	Rotators (optional)	12
4.1.4	Fork sleeves (optional)	13
4.2	Installation of the steelfinger grippers WB-SQ	14
5	Adjustments	15
5.1	Adjustment of the gripping range	15
5.2	Accessoires– HVA for batch processing	17
6	Operation	18
6.1	Gripping, moving and laying of gripping goods	18
6.2	Picture of the automatic release	19
6.3	Operation: Steelfinger grippers WB-SQ	20
7	Maintenance and care	22
7.1	Maintenance	22
7.1.1	Mechanics	22
7.1.2	Additional with steelfinger grippers (WB-SQ)	23
7.2	Trouble shooting	24
7.3	Repairs	24
7.4	Safety procedures	25
7.5	Hints to the type plate	26
7.6	Hints to the renting/leasing of PROBST devices	26
8	Disposal / recycling of devices and machines	26

We hereby reserve the right to make changes to the information and illustrations in the operating instructions.

1 EC-Declaration of Conformity / UKCA-Declaration of Conformity

Description: Concrete Step Handles TSZ
 Type: TSZ-UNI
 Order number: 53100338

Manufacturer: Probst GmbH
 Gottlieb-Daimler-Straße 6
 71729 Erdmannhausen, Germany
 info@probst-handling.de
 www.probst-handling.com



Importer: Probst Ltd
 Unit 2 Fletcher House
 Stafford Park 17
 Telford Shropshire TF3 3DG, United Kingdom
 www.probst-handling.co.uk
 sales@probst-handling.co.uk



The machine described above complies with the relevant requirements of the following EU directives:
The object of the declaration described above is in conformity with the relevant UK-Regulations and UK-Guidelines:

EC-machinery directive 2006/42/EC (Reference: OJ L 157, 09.06.2006)

UK-Regulation: Supply of Machinery (Safety) Regulations 2008 (SI 2008 No. 1597)

The following standards and technical specifications were used:

DIN EN ISO 12100

Safety of machinery - General principles for design - Risk assessment and risk reduction

UK-Regulation: BS EN ISO 12100-1:2003+A1:2009

DIN EN ISO 13857

Safety of machinery - safety distances to prevent hazard zones being reached by upper and lower limbs.

UK-Regulation: BS EN ISO 13857:2019

Authorized person for EC-documentation:

Name: Jean Holderied
 Address: Probst GmbH; Gottlieb-Daimler-Straße 6; 71729 Erdmannhausen, Germany

Authorized person for UK-documentation:

Name: Nigel Hughes
 Address: Probst Ltd ; Unit 2 Fletcher House; Stafford Park 17; Telford Shropshire TF3 3DG, United Kingdom

Signature, information to the subscriber:



Erdmannhausen, 02.08.2023.....
 (Eric Wilhelm, Managing Director)

2 Safety

2.1 Safety symbols



Danger to life!

Identifies imminent hazard. If you do not avoid the hazard, death or severe injury will result.



Hazardous situation!

Identifies a potentially hazardous situation. If you do not avoid the situation, injury or damage to property can result.



Prohibition!

Identifies imminent a prohibition. If you do not avoid the prohibition, death and severe injury, or damage to property will result.



Important information or useful hints for the usage.

2.2 Explanation of basic concepts

Gripping range:	<ul style="list-style-type: none"> specify the minimum and maximum product measurements of the gripping good, which can be gripped with this device.
Gripping good(s):	<ul style="list-style-type: none"> is the product, which will be gripped or transported.
Opening width:	<ul style="list-style-type: none"> consists of the gripping range and the measure to drive over the gripping good. <i>$\text{gripping range} + \text{measure to drive over the gripping good} = \text{opening width}$</i>
Immersion depth:	<ul style="list-style-type: none"> is the maximum gripping height of gripping goods, conditional of the height of the gripping arms of the device.
Device:	<ul style="list-style-type: none"> is the description for the gripping device.
Product dimensions:	<ul style="list-style-type: none"> Are the dimensions of the gripping good (e.g. length, breadth, height of the product).
Dead weight:	<ul style="list-style-type: none"> is the own weight (without gripping good) of the device.
Carrying capacity/working load limit (WLL*):	<ul style="list-style-type: none"> specify the maximum possible load of the device (for lifting of gripping goods). *= WLL → (english:) <u>W</u>orking <u>L</u>oad <u>L</u>imit
Area in proximity to the ground:	<ul style="list-style-type: none"> the gripping good must be lowered to just above the ground (approx. 0.5 m) immediately after being picked up (e.g. from a pallet or from a truck). For transport, lift the gripping good only as high as necessary (recommendation approx. 0.5 m above the ground).

2.3 Definition skilled worker / specialist

Only skilled workers or specialists are allowed to carry out the installation-, maintenance-, and repair work on this device!

Skilled workers or specialists must have for the following points (if it applies for this device), the necessary professional knowledge.

- for mechanic
- for hydraulics
- for pneumatics
- for electrics

2.3.1 Explanation of the pictograms

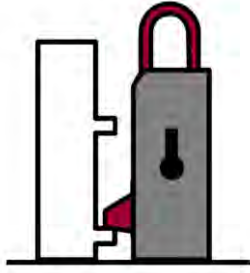

Automatic release is „empty“

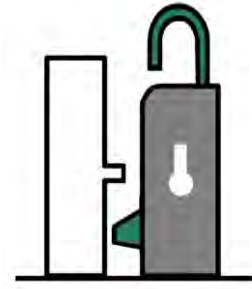

Automatic release is „full“

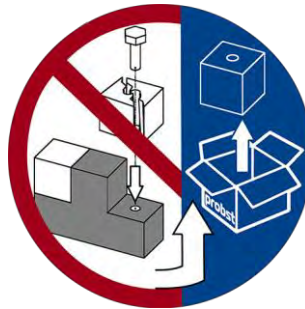

Do not use damaged accessories, replace if necessary!



Do not hold limbs under the lifted load!
Risk of injury!



Allowed slings: hook and lifting strap.





Load securing chain (lashing chain) must not be used as sling chain!
The load securing chain can break and the load would fall!
Risk of injury and death!



If the load falls into the load securing chain, the chain must be checked professionally and replaced if necessary.
Do not continue to use damaged load-securing chains!

2.4 Safety Marking



PROHIBITION SIGN

Symbol	Meaning	Order-No.	Size
	It is not allowed to stand under hanging loads. Danger to life!	29040210 29040209 29040204	Ø 30 mm Ø 50 mm Ø 80 mm
	The transportation of non-rectangular goods is not allowed!	29040213 29040212 29040211	Ø 30 mm Ø 50 mm Ø 80 mm
	Do not lift any components off-centre (always in centre of gravity).	29040216 29040215 29040214	Ø 30 mm Ø 50 mm Ø 80 mm

WARNING SIGN

Symbol	Meaning	Order-No.	Size
	Danger of squeezing the hands.	29040221 29040220 29040107	30 x 30 mm 50 x 50 mm 80 x 80 mm

REGULATORY SIGN

Symbol	Meaning	Order-No.	Size
	Each operator must have read and understood the operating instructions (and all safety instructions).	29040665 29040666 29041049	Ø 30 mm Ø 50 mm Ø 80 mm
	The manual guiding of the device is only allowed at the red handles.	29040227 29040226 29040225	Ø 30 mm Ø 50 mm Ø 80 mm

OPTIONAL

	Be sure that the fork sleeves are mechanically fixed (with locking screw and safety chain or rope) to the lifting device.	29040223 29040222	Ø 50 mm Ø 80 mm
---	---	----------------------	--------------------

2.5 Personal safety requirements



Each operator must have read and understood the operating instructions (and all safety instructions). Only qualified, authorized personal is allowed to operate the device and all devices which are connected (lifting device/carrier).



The **manual guiding** is **only** allowed for devices **with handles**. **Otherwise there is a risk of injury to the hands!**

2.6 Protective equipment

The protective equipment must consist, according to the safety regulations of the following parts:

- Protective clothing
- Safety gloves
- Safety shoes

2.7 Accident prevention



- The workplace has to be covered for unauthorized persons, especially children.
- **Caution at thunderstorm - danger of lightning!**
Depending on the intensity of the thunderstorm, stop working with the device if necessary.



- The workplace must be sufficiently illuminated.
- **Be careful with wet, frozen, iced and dirty building materials! There is a danger of the gripping material slipping out. → DANGER OF ACCIDENT!**

2.8 Function Control

2.8.1 General



- Before every usage of the device check the functions and the working condition.
- Maintenance and lubrication are only permitted when device is shut down!



- Do not use the device, until all faults which can cause safety hazards are removed.
- If there are any cracks, splits or damaged parts on any parts of the device, immediately stop using it.



- The operating instructions must be available at the workplace every time.
- Do not remove the type plate of the machine.
- Unrecognisable information signs (such as regulatory or prohibition signs) must be replaced.

2.9 Safety procedures

2.9.1 General



- The use of the device is only permitted in proximity to the ground. Do not swing it over people heads.
- The stay under lifted load is forbidden. **Danger to Life!**



- The manual guiding of the device is only allowed at the handles.



- While using the device the stay of persons in the working area is forbidden. Except it is indispensable, caused of the way of using the device, e.g. if the device must be leaded by hand.
- Jerky lifting or lowering of the device with or without load is **prohibited**, as well as driving fast with the carrier device/lifting device over uneven terrain! In general, with the load lifted, drive with the lifting equipment (e.g. excavator) **only at walking speed** - avoid unnecessary vibrations. **Danger:** Load could fall down or load handling equipment could be damaged!



- Do not lift any components off-centre (always in centre of gravity), because that **could fall down**.
- The device should not be opened if the opening path of the gripping arm is blocked by a resistance (e.g. other concrete blocks or the like)!



- The operator is not allowed to leave the control unit as long as the device loaded with load. The load must always be in the range of vision of the operator.
- Never exceed the carrying capacity/working load limit (WLL) and the nominal width/gripping range of the device.



- Do not pull out stuck or tightened loads with the device.
- **Never** pull or drag loads sideways. Otherwise parts of the device could be damaged. (see Fig. A →)

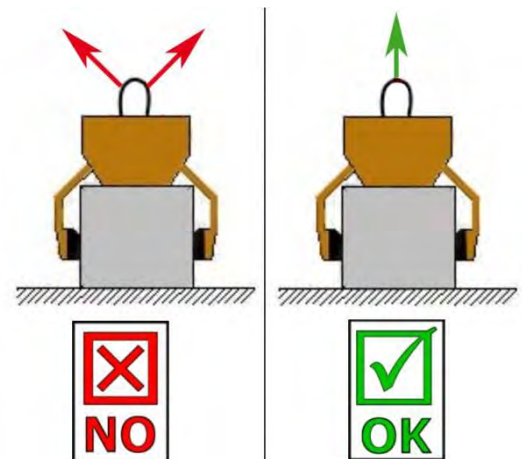

Fig. A

2.9.2 Carrier / Lifting device



- The used carrier/lifting device (e.g. excavator) have to be in good, safe working condition.
- Only authorized and qualified persons are allowed to operate the carrier/lifting device.
- The operator of the carrier/lifting device must have all the necessary qualifications.



- **Never exceed the maximum allowable carrying capacity/working load limit (WLL) of the carrier/lifting device and the lifting gear.**

3 General

3.1 Authorized use

The device TSZ-UNI is specially designed for gripping, transporting and the following laying of gripping goods such as, steps, kerb stones, contact angle and L-stones. Via the assembly of the accessoire "steelfinger grippers WB-SQ" ashlar rocks can also be gripped.

The device is used in conjunction with a corresponding lifting device (e.g. excavator).



- The device is only designed for the use specified in this documentation.
- Every other use is not authorized and is forbidden!
- All relevant safety regulations, corresponding legal regulations, especially regulations of the declaration of conformity, and additional local health and safety regulations must be observed.



Prior to every operation the user **must** ensure that:

- The equipment is suited to the intended operation
- the functioning and the working condition of the equipment is examined
- the load is suitable to be handled.

Any doubts about instructions should be raised with the manufacturer prior to use.



ATTENTION: The use of this device is only permitted in proximity to the ground (→ chapter "Safety at work" and "Explanation of basic concepts").



Only stone elements with parallel and plane surface are allowed to be picked-up and handled. Because the gripping good could **fall down**.



NOT ALLOWED ACTIVITIES:

Unauthorized alterations of the device and the use of any self-made additional equipment could cause danger and are therefore **forbidden!**

Carrying capacities / working load limits(WLL) of the device must not be exceeded and nominal widths/gripping ranges must not be exceeded or fallen below.

All unauthorized transports with the device are strictly prohibited:

- Transport of people and animals.
- Gripping and transporting of other loads and materials than described in this operating instruction.
- Never suspend any goods with ropes, chains or similar at the device, except at the designated lifting eyes/-bolts.
- Gripping of gripping goods with packaging foil, because they could fall down.
- Gripping of gripping goods with surfaces that reduce the coefficient of friction (e.g., abrasive, treated, dirty, frozen, coated, painted surfaces), as this causes a reduction in the coefficient of friction between the grippers and the gripping goods → **Danger of slipping!**
Remedy: In case of dirt of any kind, it is absolutely necessary to clean the grippers and the surface of the products in the area of the grippers **before each** gripping process!
- Gripping of gripped goods, which can deform or break due to the clamping force of the gripping device!
- Gripping of goods which show visible damage, or which may break due to their own weight.
- Gripping and transporting of non-rectangular and round gripping goods, because they could fall down (see figure to the right). →
- Transportation of material with “feet”, “bellies” and “blind spacers”.

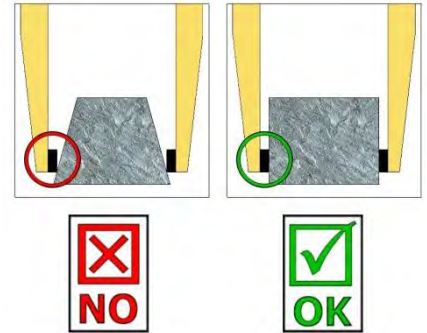

3.2 Survey and construction

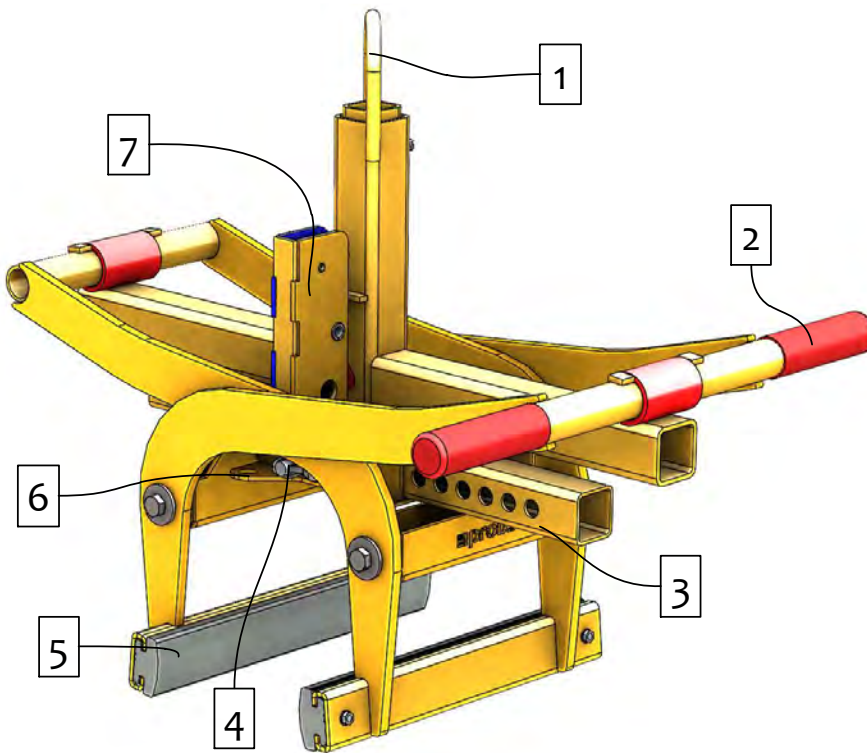

1. Lifting eye for attaching to crane hook
2. Handles for the guidance of the device
3. Adjustment of gripping range
4. Spring bolt (for gripping range adjustment)
5. Rubber gripper (exchangeable)
6. Montageplatte für HVA
7. Automatic release for the fully automatic switch over from "full" to "empty"

3.3 Accessoires

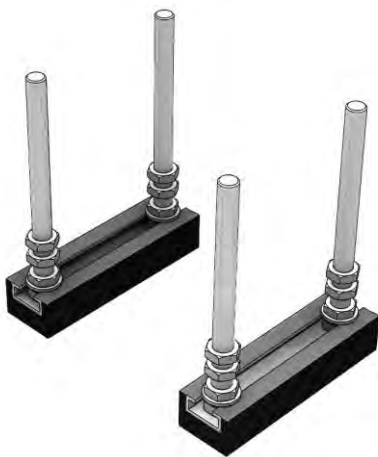

HVA-FTZ/TSZ
Laying in batch operation

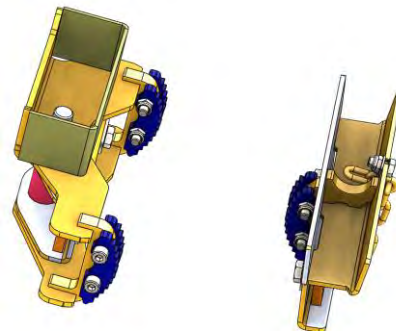

TSZ-UNI-WB-SQ
Gripping of roughly-cut ashlar rocks

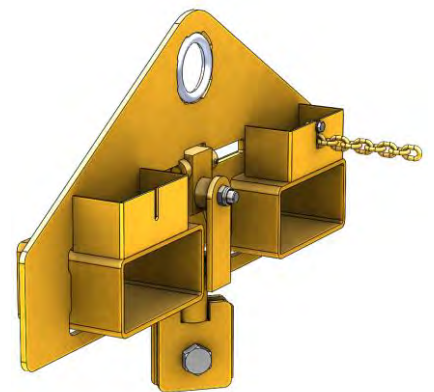

TSZ-UNI-ET
Fork sleeve

3.4 Technical data

The exact technical data (carrying capacity / working load limit (WLL), dead weight, etc.) are listed on the type plate.

4 Installation

4.1 Mechanical connection

Use only original accessories, in case of doubt consult the manufacturer.



Take care that the **carrying capacity / working load limit (WLL)** of the lifting device/carrier is **not exceeded**, through the load of the device, the optional attaching devices (turning device, fork sleeves, crane boom etc.) and the additional load of the gripping goods!

Gripping devices **always** have to be **gimballed**, so they can swing freely in any position.



In **no case** it is allowed to mount gripping devices with lifting devices/carriers in a **rigid way!**
Break of the suspension may occur within short time. Death, severe injuries and material damage can result!



When using the device on optional attachments (such as fork sleeves, crane boom, etc.), it cannot be excluded, due to the lowest possible construction of the total device (to avoid loss of lifting height), that the device may collide with adjacent components if the device is suspended in an oscillating motion and unfavourable positioning during travel movements of the carrier device. This should be avoided as far as possible by positioning the device appropriately and in a sensible driving style. Damage resulting from this will not be regulated within the scope of the warranty.

4.1.1 Lifting eye / Suspension bolt

The device is equipped with a lifting eye / suspension bolt and can be mounted on various carrier / lifting devices.



Take care that the lifting eye / suspension bolt is safely joined with the lifting tackle (e.g. crane hook, belt) and cannot slide down.

4.1.2 Load hooks and lifting tackle



The device is attached to the carrier/lifting device with a load hook or a suitable lifting tackle.

Ensure that the single chains strands are not twisted or knotted.

Attaching the device to the lifting device/carrier, take care that all local safety regulation is observed.

4.1.3 Rotators (optional)



When using rotators, a free-wheel throttle valve **must be** installed.

In order to prevent a sudden speedup and stopping the rotational movements, as this may **damage** the device within a short time.

4.1.4 Fork sleeves (optional)



In order to connect the forklift truck and the fork sleeve (3), the forklift truck forks (1) are inserted into the fork sleeve (3). The forks (1) are locked either by using the locking screws (2), which are inserted through a hole in the forks (1), or by using a chain or rope, which must be placed through the eyelet on the fork sleeve (3) and around the fork carrier (4).



This connection must be made, otherwise the fork sleeve may slip off the forklift forks during forklift handling. **DANGER OF ACCIDENT!**

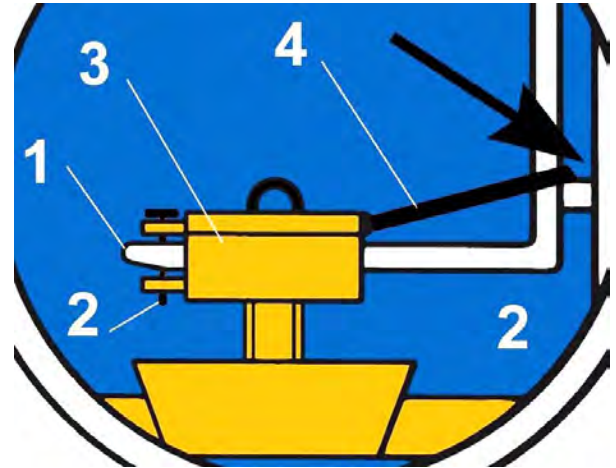
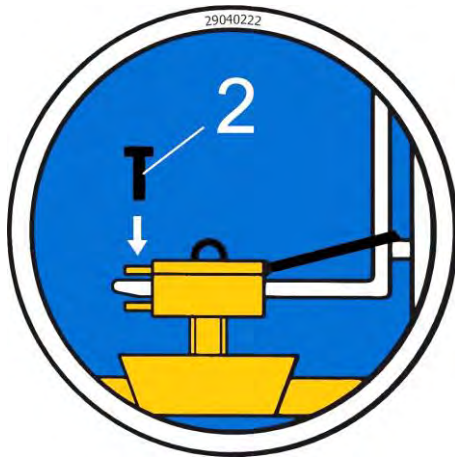

4.2 Installation of the steelfinger grippers WB-SQ

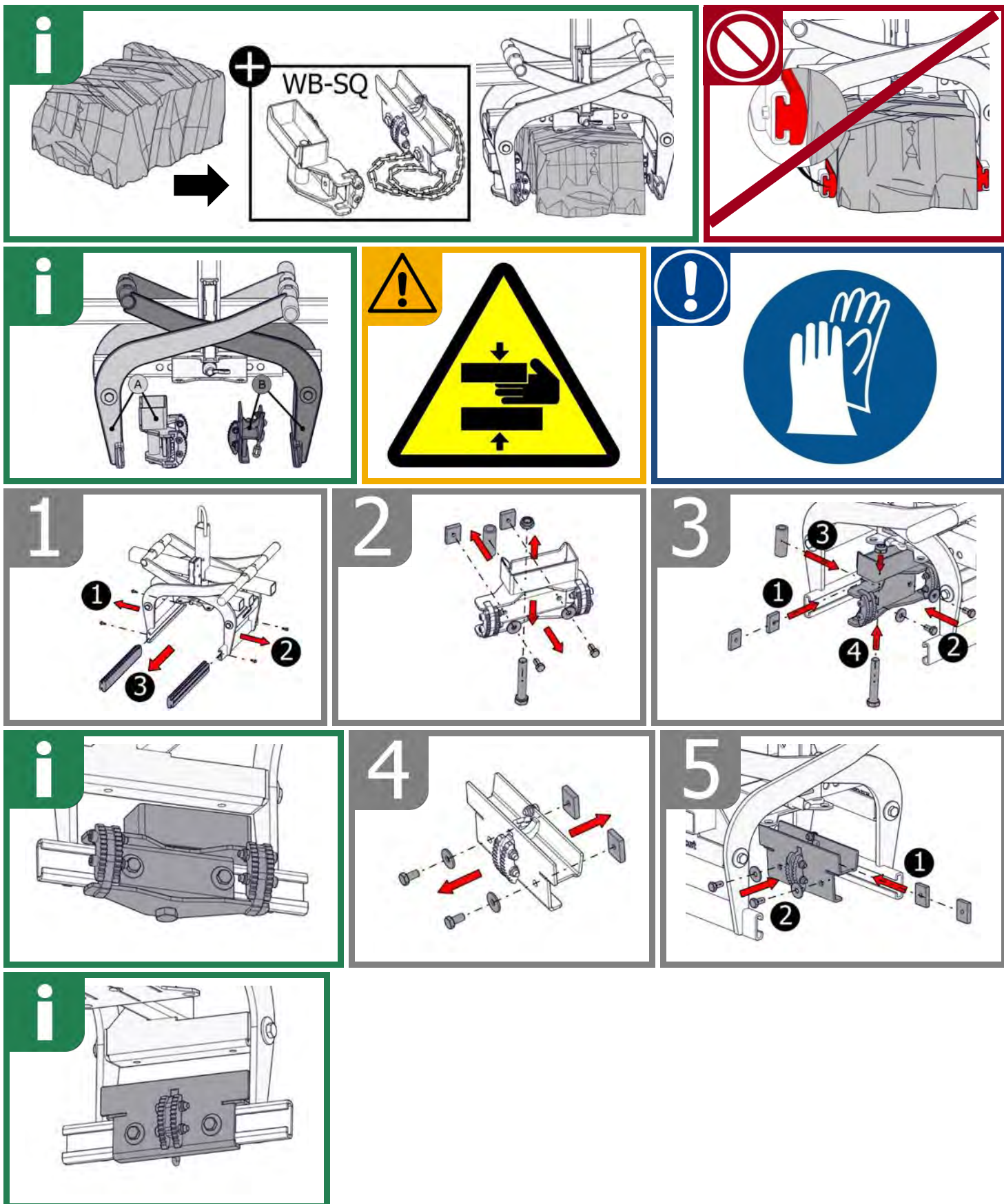

5 Adjustments

5.1 Adjustment of the gripping range

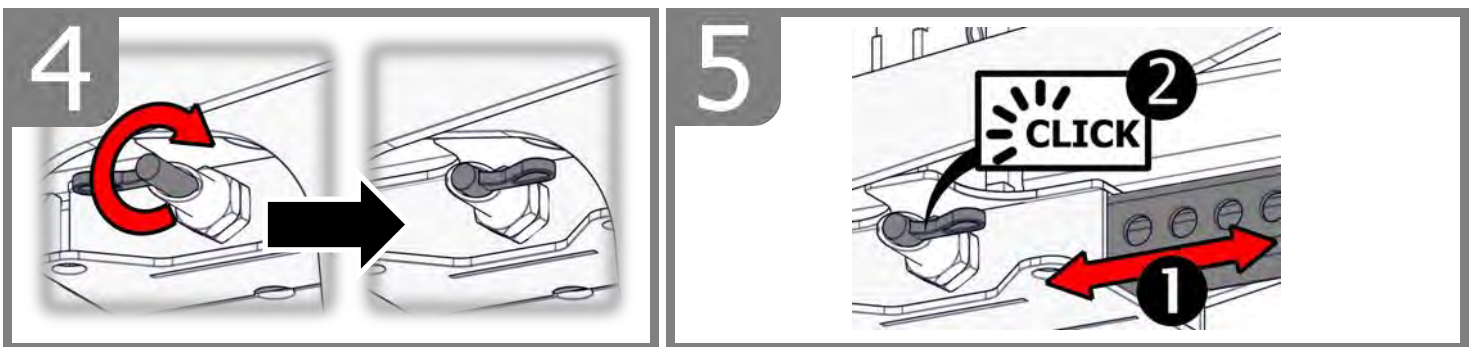
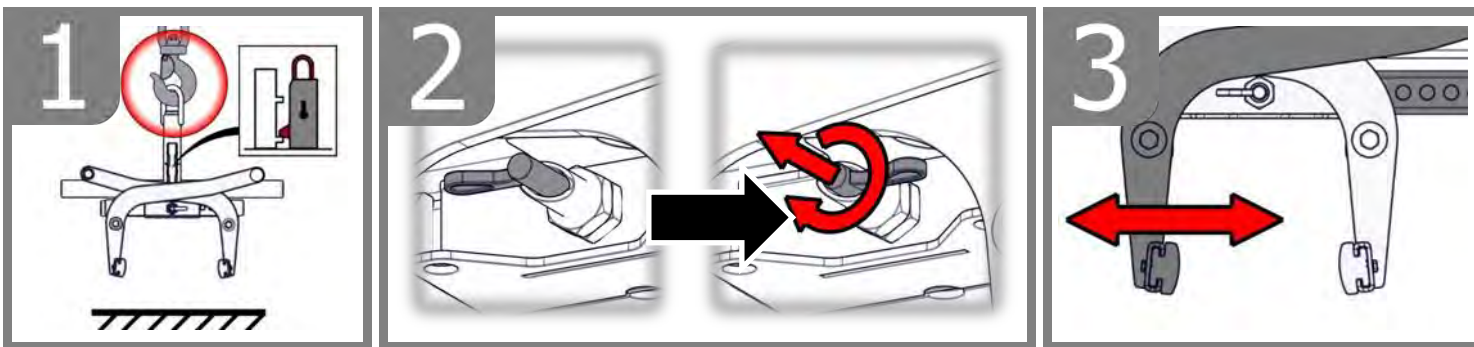
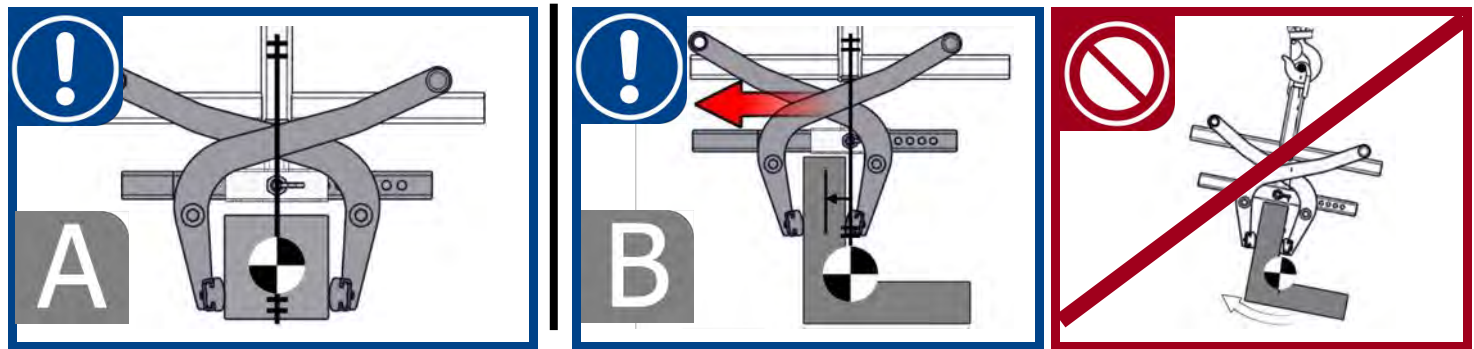
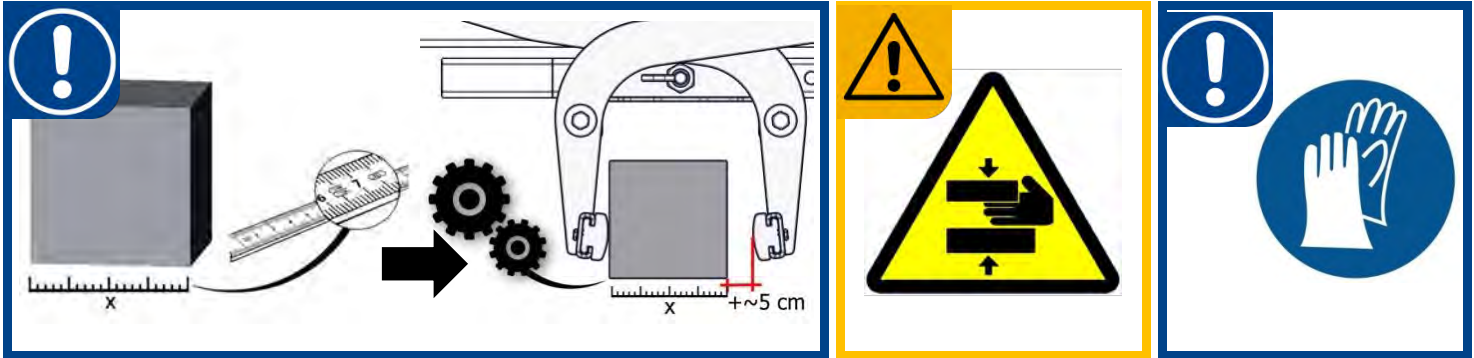

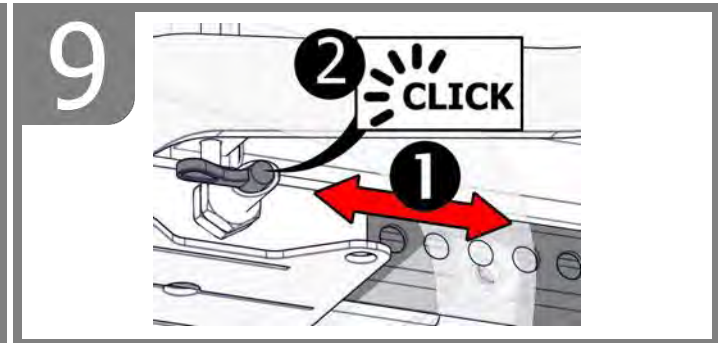
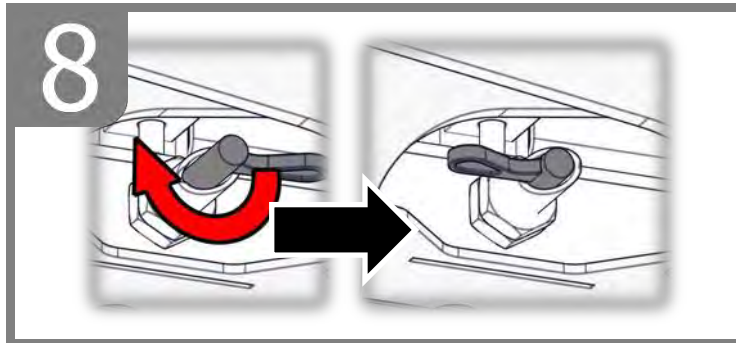
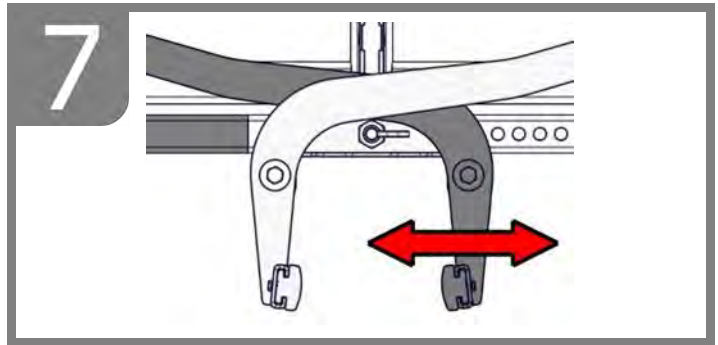
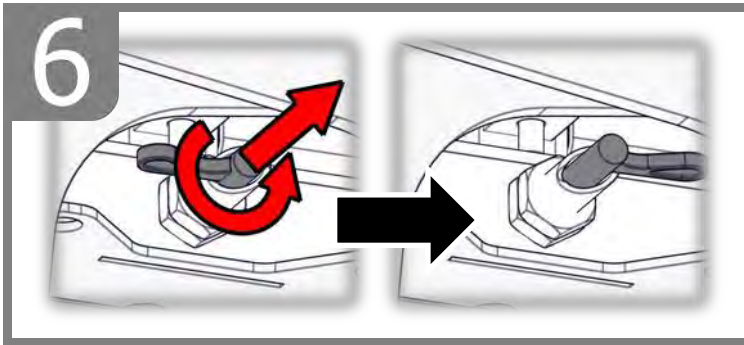

5.2 Accessoires– HVA for batch processing

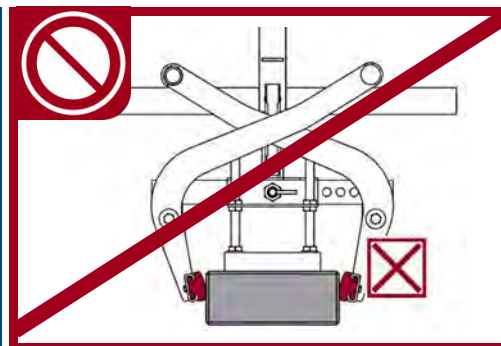
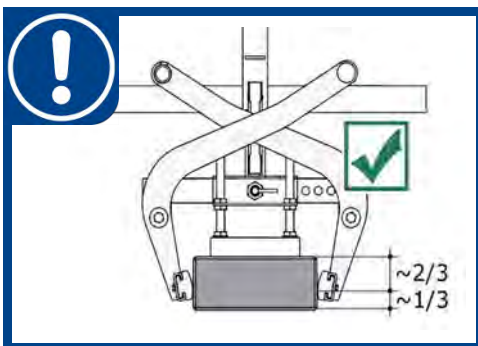
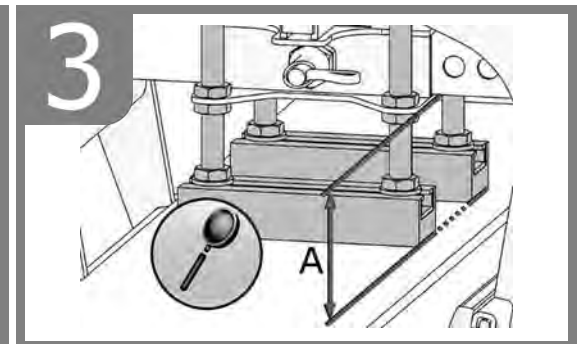
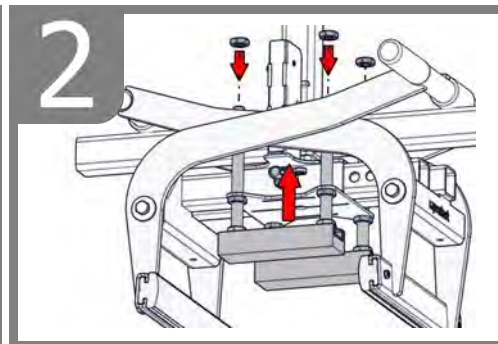
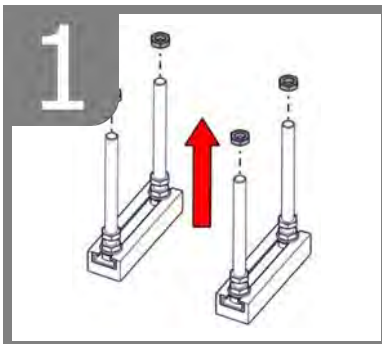
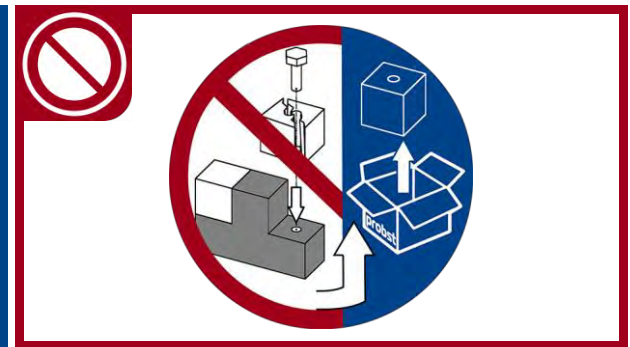
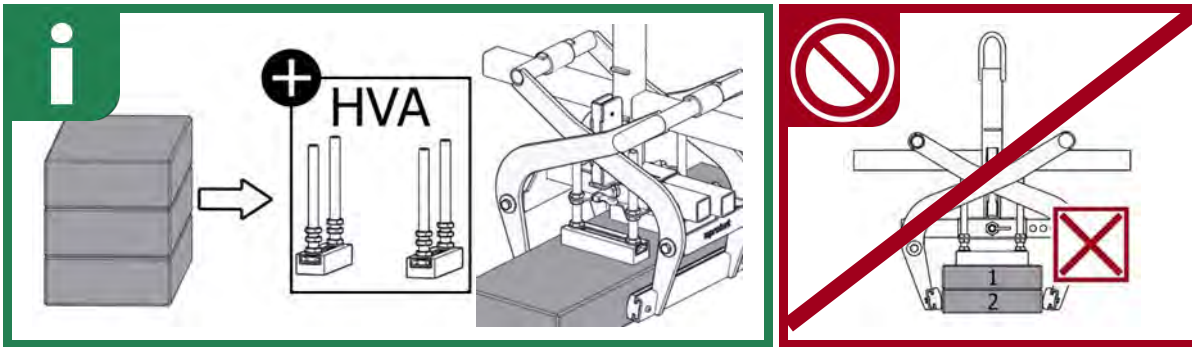

6 Operation

6.1 Gripping, moving and laying of gripping goods

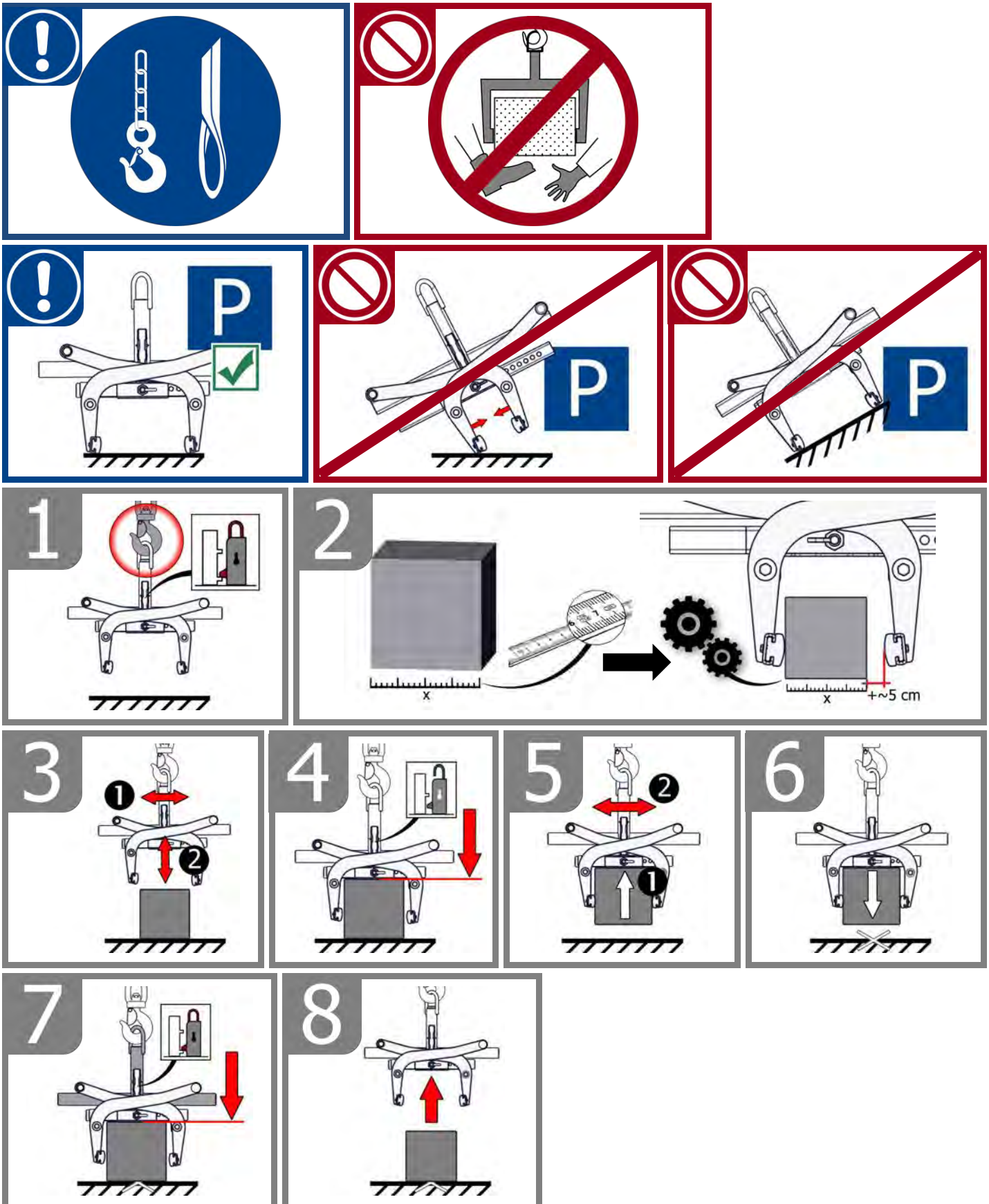

6.2 Picture of the automatic release

The device is equipped with an automatic release, that means the OPENING and CLOSING of the gripping arms results through the set down and lifting of the device.

Pictures of the positions of the automatic release:

<p>1</p> <ul style="list-style-type: none"> • Device is lifted through the lifting equipment/carrier • Gripping arms are opened 	<p>2</p> <ul style="list-style-type: none"> • Device is set up on the gripping good • Gripping arms are opened 	<p>3A</p> <ul style="list-style-type: none"> • Device is lifted through the lifting equipment/carrier • Gripping good is clamped and can be transported to the destination
<p>3B</p> <ul style="list-style-type: none"> • With faulty switching, the change-over switch must be pushed back manually (e.g. with a screwdriver)¹⁾ 	<p>4</p> <ul style="list-style-type: none"> • Device is set down with the gripping good (on the ground) • Gripping arms are opening 	<p>5/1</p> <ul style="list-style-type: none"> • Device is lifted through the lifting equipment/carrier • Gripping arms are opened (laydown position of the device on the ground)



¹⁾ Otherwise there may be faulty switching and when setting down the load this can cause deformation or damage of the automatic release!

The jerky lifting and lowering of the device with and without load. e.g. caused through driving fast with the lifting equipment/carrier over uneven grounds is **forbidden**



When replacing a defective automatic release, it is essential to ensure that the slots of the two clamping pins **always** point downwards.

The position of the slots **must not be** above or center, otherwise there is a risk that the automatic release may jam when switching!

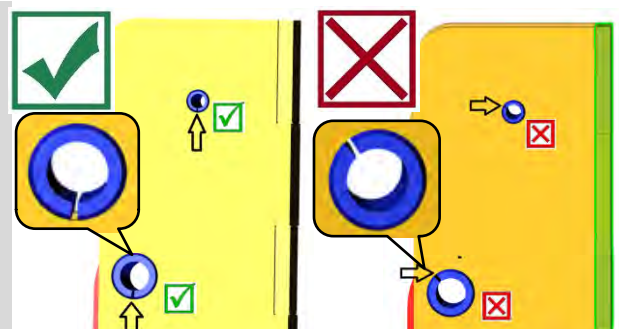

6.3 Operation: Steelfinger grippers WB-SQ

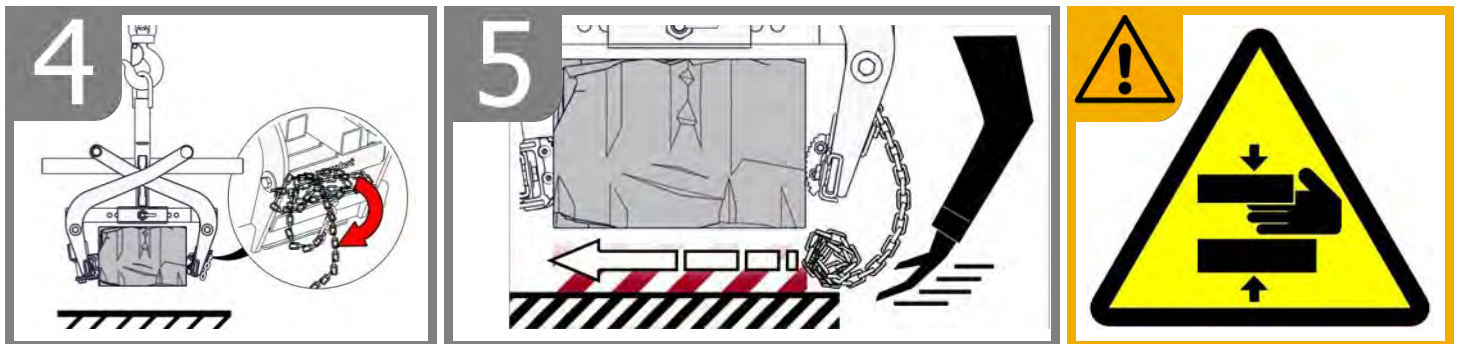
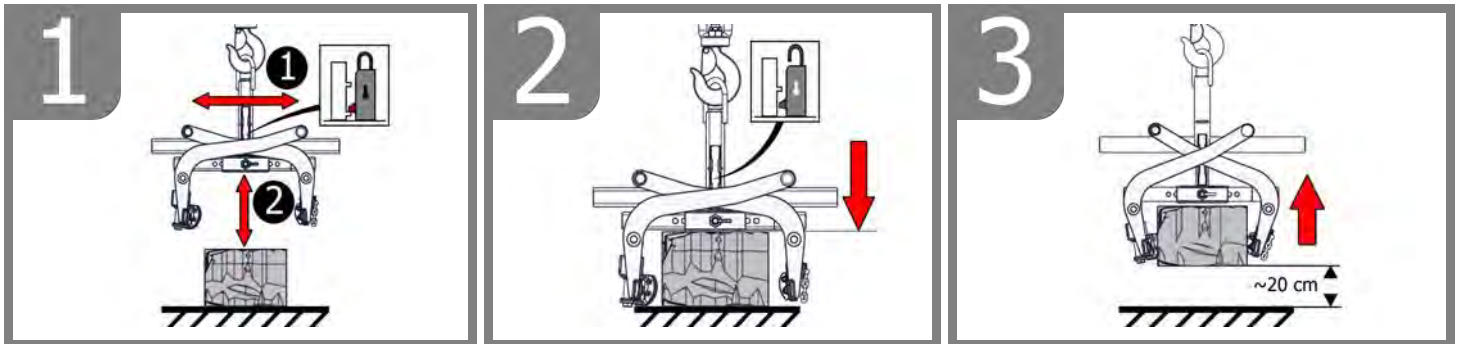
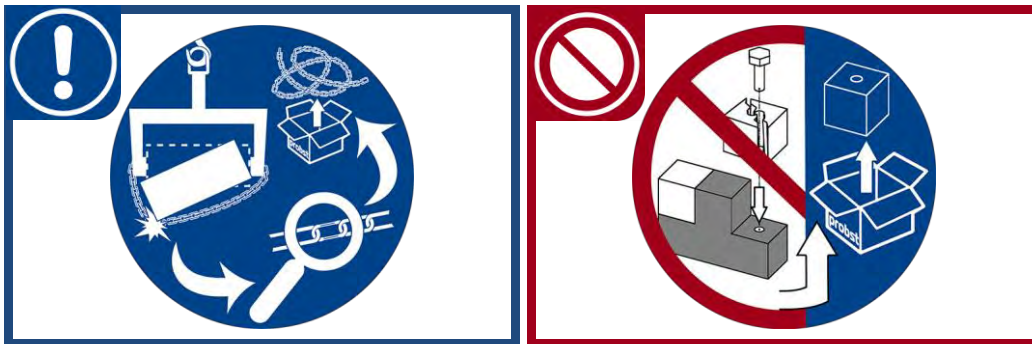
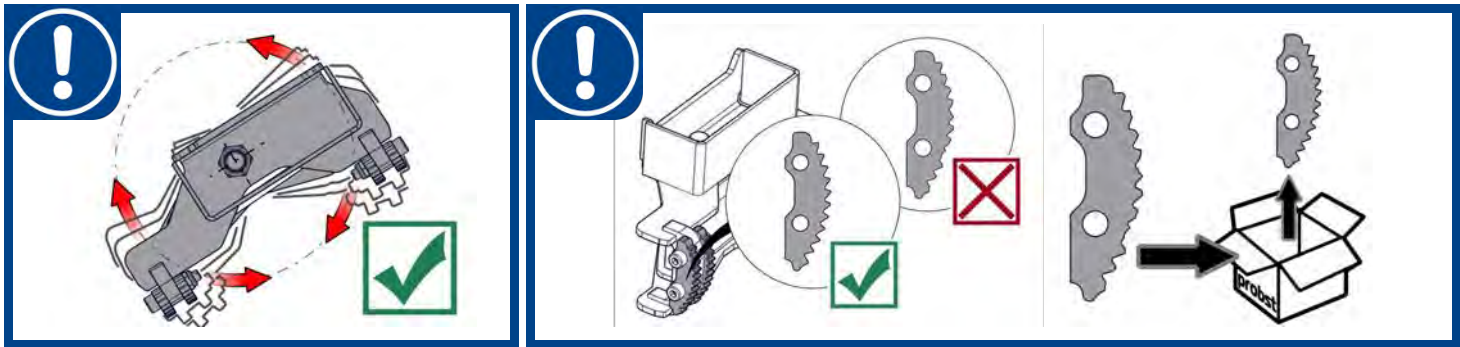

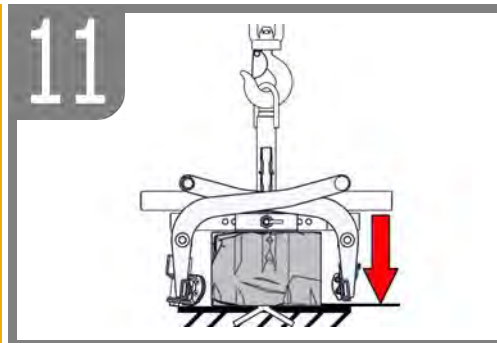
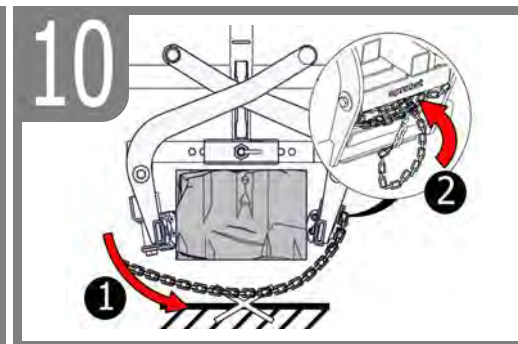
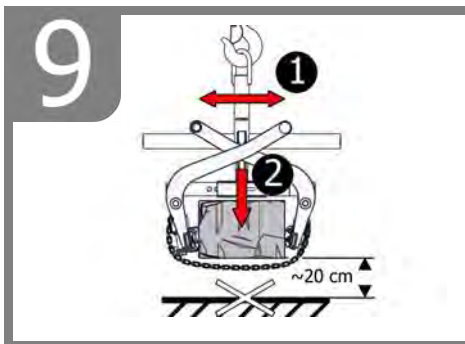
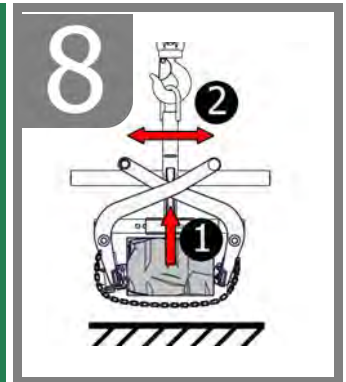
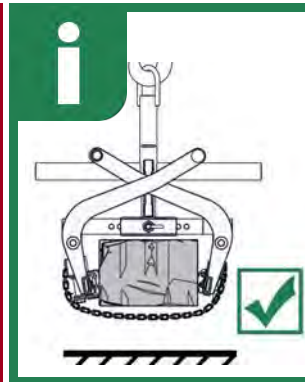
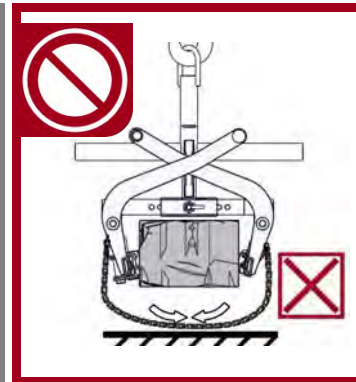
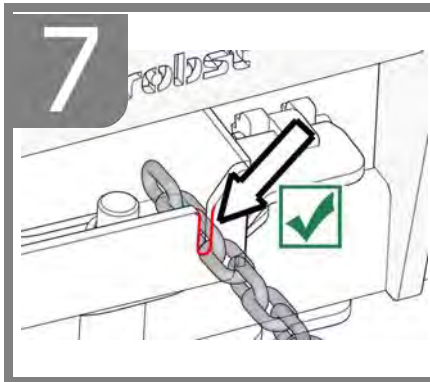
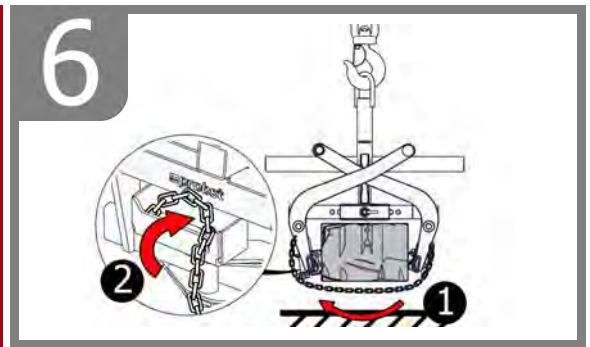

7 Maintenance and care

7.1 Maintenance



To ensure the correct function, safety and service life of the device the following points must be executed in the maintenance interval.

Used **only original spare parts**, otherwise the warranty expires.



All operations may only be made in closed state of the device!
For all operations you have to make sure, that the device will not close unintended. **Danger of injury!**

7.1.1 Mechanics

MAINTENANCE PERIOD	Work to be carried out
Initial inspection after 25 operating hours	<ul style="list-style-type: none"> Check or retighten all fixing screws (may only be carried out by a qualified person).
Every 50 operating hours	<ul style="list-style-type: none"> Retighten all fixing screws (make sure that the screws are retightened according to the valid tightening torques of the corresponding strength classes). Check all existing safety elements (such as folding pins) for proper function and replace defective safety elements. → 1) Check all joints, guides, pins and sprockets, chains for proper function, readjust or replace if necessary. Check gripper jaws (if present) for wear and clean, replace if necessary. All existing sliding guides, rack gears and joints of moving parts or machine components must be greased / lubricated to reduce wear and for optimum movement sequences (recommended grease: Mobilgrease HXP 462). Lubricate all grease nipples (if present) with grease gun.
At least 1x per year (shorten the inspection interval in case of harsh operating conditions)	<ul style="list-style-type: none"> Inspection of all suspension parts, as well as bolts and brackets. Inspection for cracks, wear, corrosion and functional safety by an expert.

1)

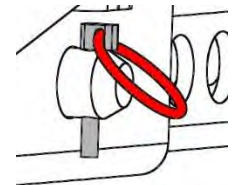
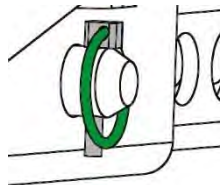

Rubber gripper bar



Regular control for dirt (e.g. little stone particles) in the upper area (see points in figure detail „X“ in Fig. 2) of the rubber gripper bar (6) → see Fig. 1 / Fig. 2

Problem: Dirt can damage the rubber gripper bar (6) when gripping (when little stone particles are pressed into the rubber gripper bar).

Redress: Remove the dirt in this area at the rubber gripper bar (6), or when heavy polluted, dismount and clean the rubber gripper bar.

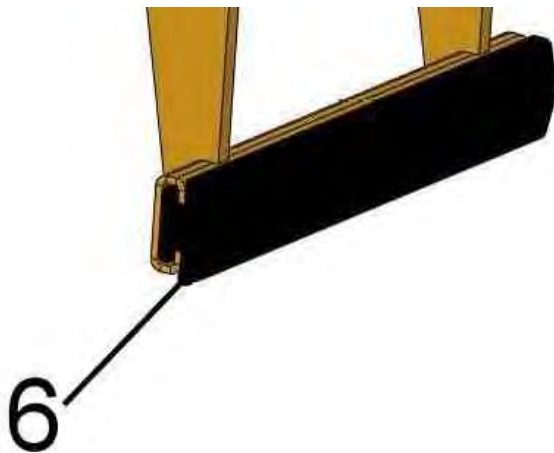

Fig. 1

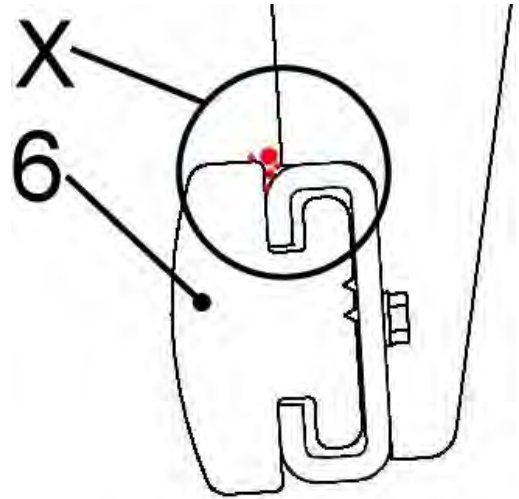

Fig. 2

7.1.2 Additional with steelfinger grippers (WB-SQ)

Before each start-up:	<ul style="list-style-type: none"> • Check all steelfinger grippers for mobility, abrasion and contamination. Worn (no longer sharp-edged) or bent steelfinger grippers must be replaced!
Regular:	<ul style="list-style-type: none"> • Cleaning of the device with high pressure cleaner (warm water).
Weekly:	<ul style="list-style-type: none"> • Lubricate and oil mobile parts

AUTOMATIC-RELEASE



Never grease or oil the automatic-release!
Clean with high-pressure cleaner when the automatic-release is dirty.

7.2 Trouble shooting

ERROR	CAUSE	REPAIR
The clamping-power is not big enough, the load is slipping out		
(optional)	The grippers are worn	Replace the grippers
(optional)	The maximum load is exceed	Reduce the weight of. the load
(Adjustment of the gripping range) (optional)	The actual opening width is not correct	Adjust the gripping range according to the load you want to transport
(Property of material)	The surface of the material is dirty or the material is not suitable / allowed for this device.	Check the surface of the material or ask the manufacturer, if you the material is allowed for this device.
Unbalanced load		
	The device is not loaded symmetrically	Adjust the position of the load
(Adjustment of the gripping range) (optional)	The adjustment of the gripping range is not symmetrical.	Correct the adjustment of the gripping range
Automatic release does not work		
mechanical (optional)	Automatic release does not work	Clean automatic release with high pressure-cleaner Correct faulty switching (→see chapter "Picture of the automatic release") Change the inset of the automatic release

7.3 Repairs



Only persons with the appropriate knowledge and ability are allowed to repair the device. Before the device is used again, it **has to be** checked by a qualified person or an expert.

7.4 Safety procedures



- It is the contractor's responsibility to ensure that the device is checked by an expert in periods of max. 1 year and all recognized errors are removed (→ DGUV norm 100-500).
- The corresponding legal regulations and the regulations of the declaration of conformity must be observed!
- The expert inspection can also be done by the manufacturer Probst GmbH.
Contact us at: service@probst-handling.de
- We recommend affixing the inspection sticker "„Sachkundigenprüfung / Expert inspection" in a clearly visible place (order no.: 2904.0056+Tüv sticker with year number) after the inspection has been done.



The check by an expert must be proved!

Device	Year	Date	Expert	Company

7.5 Hints to the type plate



- Type, serial-number and production year are very important for the identification of your device. If you need information to spare-parts, warranty or other specific details please refer to this information's.
- The maximum carrying capacity/working load limit (WLL) is the maximum load which can be handled with the device. **Do not** exceed this carrying capacity/working load limit (WLL).
- If you use the device in combination with other lifting equipment (Crane, chain hoist, forklift truck, excavator) consider the deadweight of the device.



Example:

7.6 Hints to the renting/leasing of PROBST devices



With every renting/leasing of PROBST devices the **original operating instructions must be included** unconditionally (in deviation of the user's country's language, the respective translations of the original operating instructions must be delivered additionally)!

8 Disposal / recycling of devices and machines



The product **may only** be taken out of service and prepared for disposal / recycling by qualified personnel. Correspondingly existing **single components** (such as metals, plastics, liquids, batteries/rechargeable batteries etc.) **must** be disposed of/recycled in accordance with the nationally/country-specific applicable laws and **disposal regulations!**



The product must not be disposed of in household waste!

Proof of maintenance



Warranty claim for this machine only apply for performance of the mandatory maintenance works (by an authorised specialist workshop)! After each completed performance of a maintenance interval the included form must be fill out, stamped, signed and send back to us immediately. ¹⁾

¹⁾ via e-mail to service@probst-handling.de / via fax or post

Operator: _____
 Device type: _____ Article -No.: _____
 Device-No.: _____ Year of make: _____

First inspection after 25 operating hours		
Date:	Maintenance work:	Inspection by company:
		Company Stamp
	
		Name / Signature

All 50 operating hours		
Date:	Maintenance work:	Inspection by company:
		Company Stamp
	
		Name / Signature
		Inspection by company:
		Company Stamp
	
		Name / Signature
		Inspection by company:
		Company Stamp
	
		Name / Signature

Minimum 1x per year		
Date:	Maintenance work:	Inspection by company:
		Company Stamp
	
		Name / Signature
		Inspection by company:
		Company Stamp
	
		Name / Signature

TSZ-UNI



FR | Instructions d'emploi

Sommaire

1	CE-Déclaration de Conformité	3
2	Sécurité	4
2.1	Instructions de sécurité	4
2.2	Définitions des termes	4
2.3	Définition du personnel qualifié / expert	4
2.3.1	Explication des pictogrammes	5
2.4	Signalisation de sécurité	6
2.5	Mesures de sécurité personnelle	7
2.6	Equipment de protection	7
2.7	Protection contre les accidents	7
2.8	Essai de fonctionnement et inspection visuelle	7
2.8.1	Généralités	7
2.9	Sécurité en cours de fonctionnement	8
2.9.1	Généralités	8
2.9.2	Appareils porteur / Appareil de levage	8
3	Généralités	9
3.1	Utilisation conforme	9
3.2	Vue d'ensemble et structure	11
3.3	Accessoires	11
3.4	Caractéristiques techniques	11
4	Installation	12
4.1	Montage sur l'appareil porteur	12
4.1.1	Œillet d'accrochage / Boulon d'accrochage	12
4.1.2	Crochets de charge et dispositif d'élingage	12
4.1.3	Têtes rotatives (en option)	12
4.1.4	Fourreaux (en option)	13
4.2	Montage des griffes de préhension en acier WB-SQ	14
5	Réglage	15
5.1	Réglage de l'ouverture	15
5.2	Accessoires - HVA pour fonctionnement par lots	17
6	Maniement	18
6.1	Saisir, déplacer et déposer des charges	18
6.2	Images du système de changement automatique	19
6.3	Fonctionnement : Griffes de préhension en acier WB-SQ	20
7	Maintenance et entretien	22
7.1	Maintenance	22
7.1.1	Mécanique	22
7.1.2	En cas d'utilisation des griffes de préhension en acier (WB-SQ)	23
7.2	Élimination des dérangements	24
7.3	Réparations	24
7.4	Devoir de contrôle	25
7.5	Informations concernant la plaque signalétique	26
7.6	Remarque concernant la location/le prêt des engins PROBST	26
8	Élimination / recyclage des appareils et des machines	26

Nous nous réservons le droit de modifier les informations et les illustrations du mode d'emploi.

1 CE-Déclaration de Conformité

Description: Pince pour pose de marches TSZ
Type: TSZ-UNI
N° de commande: 53100338



Fabricant: Probst GmbH
Gottlieb-Daimler-Straße 6
71729 Erdmannhausen, Germany
info@probst-handling.de
www.probst-handling.com

La machine décrite ci-dessus est conforme aux exigences applicables des directives UE suivantes :

Idée directrice EC 2006/42/CE

Les normes et spécifications techniques suivantes ont été utilisées:

DIN EN ISO 12100

Sécurité des machines – Principes généraux de conception – Appréciation du risque et réduction du risque

DIN EN ISO 13857

Sécurité des machines — Distances de sécurité empêchant les membres supérieurs et inférieurs d'atteindre les zones dangereuses.

Personne autorisée pour EC-documentation:

Nom: Jean Holderied

Adresse: Probst GmbH; Gottlieb-Daimler-Straße 6; 71729 Erdmannhausen, Germany

Signature, informations ou signataire:

Erdmannhausen, 28.06.2023.....
(Eric Wilhelm, Directeur général)

2 Sécurité

2.1 Instructions de sécurité



Danger mortel !

Indique un danger. Si elle n'est pas évitée, elle peut entraîner la mort et des blessures graves.



Situation dangereuse !

Indique une situation dangereuse. Le fait de ne pas l'éviter peut entraîner des blessures ou des dommages matériels.



Prohibition !

Indique une interdiction. Le non-respect de cette consigne peut entraîner la mort, des blessures graves ou des dommages matériels.



Informations importantes ou conseils d'utilisation utiles.

2.2 Définitions des termes

Prenez de la distance :	<ul style="list-style-type: none"> indique les dimensions minimales et maximales du produit à saisir avec ce dispositif.
Objet(s) à saisir:	<ul style="list-style-type: none"> est le produit qui est saisi ou transporté.
Largeur d'ouverture :	<ul style="list-style-type: none"> est composé de la plage de préhension et de la dimension d'entrée. <i>plage de préhension + dimension d'entrée = plage d'ouverture</i>
Profondeur d'immersion :	<ul style="list-style-type: none"> correspond à la hauteur de préhension maximale des marchandises à saisir, en raison de la hauteur des bras de préhension de l'appareil.
Appareil :	<ul style="list-style-type: none"> est la désignation du dispositif de préhension.
Dimension du produit :	<ul style="list-style-type: none"> sont les dimensions de la marchandise à saisir (par ex. longueur, largeur, hauteur d'un produit).
Un poids mort :	<ul style="list-style-type: none"> est le poids à vide (sans matériel de préhension) de l'appareil.
Capacité de charge (WLL *) :	<ul style="list-style-type: none"> indique la charge maximale admissible de l'appareil (pour le levage de marchandises à benne preneuse). *= WLL → (anglais :) Working Load Limit
Zone à proximité du sol:	<ul style="list-style-type: none"> le produit à saisir doit être abaissé juste après sa prise (par ex. d'une palette ou d'un camion) jusqu'à ce qu'il soit juste au-dessus du sol (env. 0,5 m). Pour le transport, ne soulever la marchandise à saisir qu'aussi haut que nécessaire (recommandation : env. 0,5 m au-dessus du sol).

2.3 Définition du personnel qualifié / expert

Les travaux d'installation, d'entretien et de réparation sur cet appareil ne doivent être effectués que par du personnel qualifié ou des experts !

Le personnel qualifié ou les experts doivent posséder les connaissances professionnelles nécessaires dans les domaines suivants, dans la mesure où ils s'appliquent à ce dispositif :

- pour les mécaniciens
- pour l'hydraulique
- pour le pneumatique
- pour l'électricité

2.3.1 Explication des pictogrammes

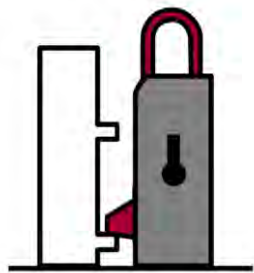

Changeur automatique fermé

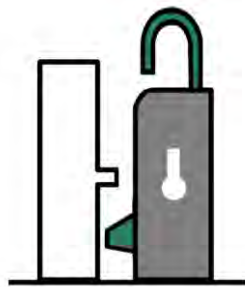

Changeur automatique ouverte

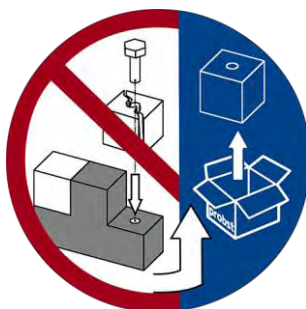

N'utilisez pas d'accessoires endommagés, remplacez-les si nécessaire !



Ne tenez pas les membres sous la charge soulevée !
!Risque de blessure !



Élingues autorisées : crochet et sangle de levage.



La chaîne d'arrimage (chaîne d'arrimage) ne doit pas être utilisée comme chaîne d'élingage !

La chaîne d'arrimage peut se briser et la charge peut tomber ! **!Risque de blessure et de mort !**





Si la charge tombe dans la chaîne d'arrimage, la chaîne doit être contrôlée par un professionnel et remplacée si nécessaire.

Ne pas continuer à utiliser des chaînes d'arrimage endommagées !

2.4 Signalisation de sécurité



PANNEAUX D'INTERDICTION

Symbole	Signification	Réf.	Taille
	Ne jamais se placer sous une charge suspendue. Danger de mort !	29040210 29040209 29040204	Ø30 mm Ø50 mm Ø80 mm
	Interdiction de saisir des produits coniques.	29040213 29040212 29040211	Ø30 mm Ø50 mm Ø80 mm
	Ne jamais saisir d'objet de manière excentrée (toujours les saisir en leur milieu).	29040216 29040215 29040214	Ø30 mm Ø50 mm Ø80 mm

PANNEAUX D'AVERTISSEMENT

Symbole	Signification	Réf.	Taille
	Risque d'écrasement des mains.	29040221 29040220 29040107	30 x 30 mm 50 x 50 mm 80 x 80 mm

PANNEAUX OBLIGATION

Symbole	Signification	Réf.	Taille
	Chaque opérateur doit avoir lu et assimilé la notice d'instructions de l'appareil, ainsi que les règles de sécurité.	29040665 29040666 29041049	Ø 30 mm Ø 50 mm Ø 80 mm
	Le guidage manuel de l'appareil n'est autorisé que si celui-ci est tenu par les poignées rouges.	29040227 29040226 29040225	Ø 30 mm Ø 50 mm Ø 80 mm

OPTIONELLES

	Utiliser des vis de blocage et cordage ou chaîne pour sécuriser les fourreaux et les fourches du chariot élévateur.	29040223 29040222	Ø50 mm Ø80 mm
---	---	----------------------	------------------

2.5 Mesures de sécurité personnelle



- Chaque opérateur doit avoir lu et assimilé la notice d'instructions de l'appareil, ainsi que les règles de sécurité.
- L'appareil et tous les appareils sur et dans lesquels l'appareil est monté ne peuvent être utilisés que par des personnes dûment mandatées, qualifiées et habilitées.



- Seules les appareils équipées de **poignées** peuvent être **dirigées à la main**.
Sinon, il y a un risque de blessure aux mains !

2.6 Equipment de protection

Conformément aux exigences techniques de sécurité, l'équipement de protection comprend:

- des vêtements de protection
- des gants de protection
- des chaussures de sécurité

2.7 Protection contre les accidents



- Protéger largement la zone de travail pour empêcher l'accès des personnes non autorisées, *en particulier des enfants*.
- **Attention en cas d'orage - danger de foudre!**
En fonction de l'intensité de l'orage, arrêtez de travailler avec l'appareil si nécessaire.



- Eclairer suffisamment la zone de travail !
- **Attention aux matériaux de construction mouillés, gelés, glacés et sales !**
Il y a un risque que le matériel de préhension glisse. → DANGER D'ACCIDENT !

2.8 Essai de fonctionnement et inspection visuelle

2.8.1 Généralités



- Le fonctionnement et l'état de l'appareil doivent être vérifiés avant chaque utilisation.
- N'effectuez l'entretien, le graissage et la remise en état de l'engin que lorsque celui-ci est à l'arrêt !



- En cas de défauts impliquant la sécurité, l'engin ne pourra être remis en service qu'après leur élimination complète.
- En présence de fissures, fentes ou parties endommagées quelconques sur des éléments quelconques de l'engin, il faut **immédiatement** arrêter d'utiliser l'engin.



- Les instructions de service de l'engin doivent pouvoir être consultées à tout moment sur son lieu d'utilisation.
- Ne pas retirer la plaque signalétique apposé sur l'engin.
- Remplacer les panneaux indicateurs illisibles (panneaux d'interdiction ou d'avertissement).

2.9 Sécurité en cours de fonctionnement

2.9.1 Généralités



- Les travaux avec l'appareil ne doivent être effectués que dans une zone proche du sol. Il est interdit de balancer l'appareil sur des personnes.
- Il est interdit de rester sous une charge suspendue. Danger pour la vie !



- Le guidage manuel n'est autorisé que pour les appareils avec poignée.



- Pendant le fonctionnement, il est interdit aux personnes de rester dans la zone de travail ! Sauf si cela est indispensable, en raison de la nature de l'application de l'appareil, par exemple en guidant manuellement l'appareil (par des poignées).
- Il est **interdit** de soulever ou d'abaisser l'appareil par à-coups, avec ou sans charge, ainsi que de rouler rapidement avec l'engin porteur/de levage sur un terrain accidenté ! En règle générale, lorsque la charge est soulevée, l'engin porteur/de levage (p. ex. pelleuse) ne doit **rouler qu'à l'allure du pas** - les secousses inutiles doivent être évitées.
Danger : la charge pourrait tomber ou le moyen de levage être endommagé !



- Ne jamais soulever la marchandise de manière excentrique (toujours au centre de gravité de la charge), sinon il y a risque de basculement.
- L'appareil ne doit pas être ouvert si la voie d'ouverture est bloquée par une résistance.
- La capacité de charge et les largeurs nominales de l'appareil ne doivent pas être dépassées.
- L'opérateur ne doit pas quitter le poste de commande tant que l'appareil est chargé et doit toujours garder la charge à vue.
- Ne pas arracher les charges collées avec l'appareil.
- Ne jamais tirer ou traîner des charges en biais. Dans le cas contraire, des parties de l'appareil pourraient être endommagées (voir fig. A).

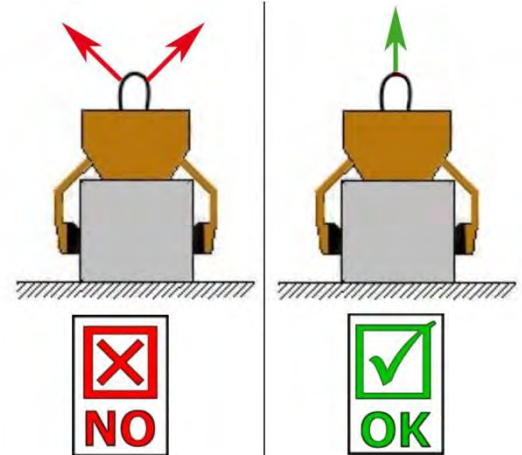

Fig. A

2.9.2 Appareils porteur / Appareil de levage



- L'appareil porteur/de levage (par ex. excavatrice) utilisé doit se trouver dans un état de fonctionnement sûr.
- Seulement des personnes mandatées et qualifiées ont le droit d'utiliser l'appareil porteur/de levage.
- L'opérateur de l'appareil porteur/de levage doit répondre aux qualifications imposées par la loi.



- **Il est strictement interdit de dépasser la charge maximale admissible de l'engin de porteur / engin de levage et dispositif d'élingage!**

3 Généralités

3.1 Utilisation conforme

Le dispositif TSZ-UNI est exclusivement destiné à la préhension, au transport et au dépôt de grappins tels que marches, bordures de trottoir, cornières et pierres en forme de L. L'accessoire en option "Griffes de préhension en acier WB SQ" permet également de saisir des blocs de pierre bruts.

L'appareil est utilisé avec un engin de levage approprié (p. ex. une pelle mécanique).



- L'appareil ne peut être utilisé que pour l'usage prévu dans la notice d'instructions, en respectant les règles de sécurité en vigueur, ainsi que les dispositions correspondantes de la déclaration de conformité.
- Tout autre usage est considéré comme non conforme à l'usage prévu et est interdit !
- Les règles légales de sécurité et de prévention des accidents applicables sur le lieu d'utilisation doivent également être respectées.



Avant chaque utilisation, l'utilisateur doit s'assurer que :

- L'appareil est adapté à l'usage prévu
- L'appareil est en bon état
- Les charges peuvent être soulevées

En cas de doute il convient de contacter le fabricant.



ATTENTION: Ne travailler avec l'engin qu'à proximité du sol (→ chapitre « Sécurité en cours de fonctionnement » et « Définitions des termes »).



Les surfaces de préhension des éléments en pierre **doivent impérativement** être parallèles et planes !
Risque de chute dans le cas contraire !



ACTIVITÉS INTERDITES :

Toute modification non autorisée de l'appareil ou l'utilisation d'appareils supplémentaires que vous avez vous-même construits met en danger la vie et l'intégrité corporelle et est donc strictement interdite !

Les capacités de charge (WLL) de l'appareil ne doivent pas être dépassées et les diamètres nominaux/plages de préhension ne doivent pas être dépassés ou ne pas être atteints.

Tous les transports avec l'appareil qui ne sont pas conformes à la réglementation sont strictement interdits:

- Le transport de personnes et d'animaux.
- La saisie et le transport de paquets de matériaux de construction, d'objets et de matériaux non décrits dans ce mode d'emploi.
- Suspendre les charges à l'aide de câbles, chaînes ou autres sur l'appareil, à l'exception des oeilletons/écrous de suspension prévus à cet effet.
- Saisir la marchandise à l'aide d'un film d'emballage, car il y a un **risque de glissement**.
- La saisie de marchandises dont la surface réduit le coefficient de frottement (par exemple, surfaces frottées, traitées, sales, gelées, revêtues, peintes), car cela réduit le coefficient de frottement entre les mâchoires de la pince et les marchandises saisies → **risque de glissement !**
Remède : si les mâchoires de préhension et la surface des produits dans la zone des mâchoires de préhension sont sales de quelque manière que ce soit, il est absolument nécessaire de les nettoyer avant chaque opération de préhension !
- Saisir des marchandises qui peuvent se déformer ou se briser en raison de la force de serrage de la pince !
- Saisir les marchandises qui présentent des dommages visibles ou qui peuvent se briser sous l'effet de leur propre poids.
- Saisir et transporter des marchandises à préhension conique et ronde, car il y a un risque de glissement. (Illustration à droite).
- Les couches de pierre qui ont des "pieds", des "ventres" ou des "entretroises aveugles"

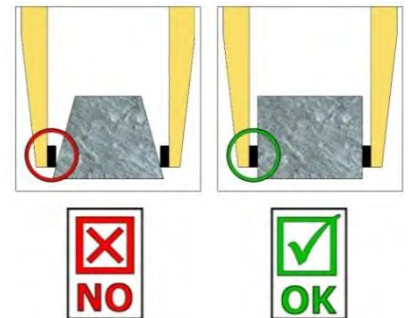

3.2 Vue d'ensemble et structure

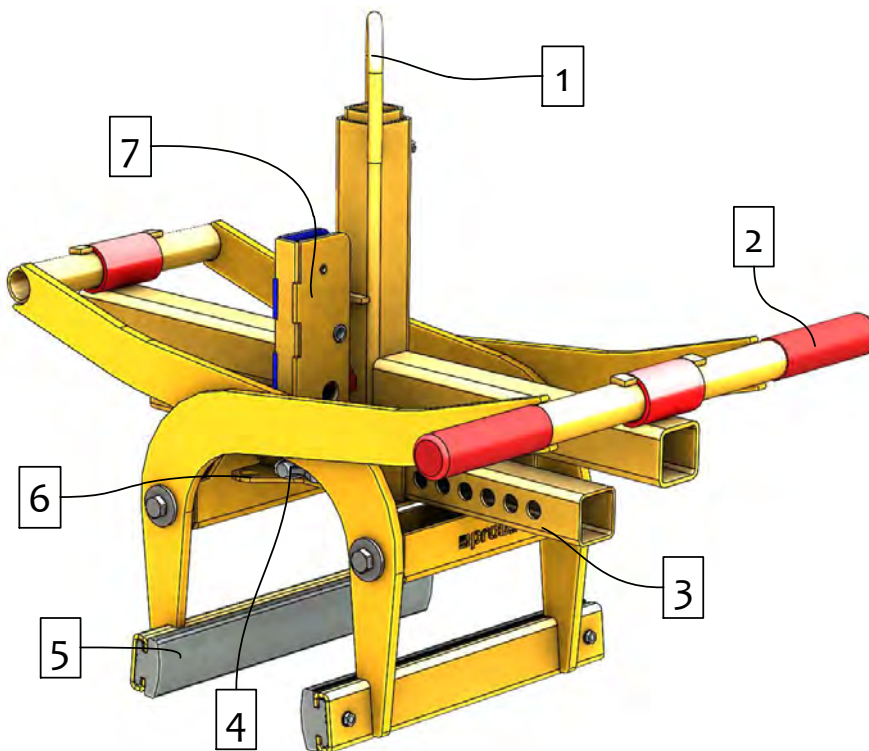

1. œillet de suspension pour crochet de grue
2. Poignée de guidage de l'appareil
3. Réglage de la plage de préhension
4. Boulon à ressort pour le réglage de la plage de préhension
5. Mâchoire de préhension en caoutchouc (interchangeable)
6. Plaque de montage pour HVA
7. Commutation automatique pour le passage entièrement automatique de la "préhension" à la "libération"

3.3 Accessoires

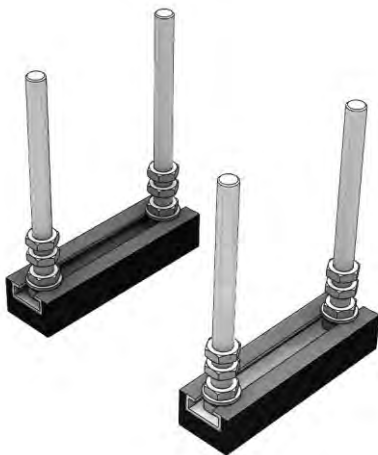

HVA-FTZ/TSZ
Pose en mode batch

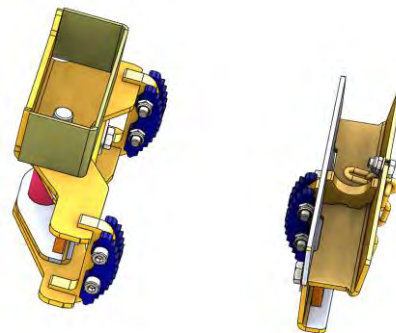

TSZ-UNI-WB-SQ
Saisir les pierres brutes taillées

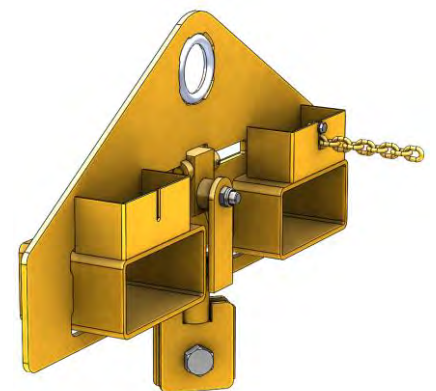

TSZ-UNI-ET
Pochette insérée

3.4 Caractéristiques techniques

Les caractéristiques techniques détaillées (par ex. charge maximale, poids propre, etc.) figurent dans la plaque signalétique.

4 Installation

4.1 Montage sur l'appareil porteur

N'utiliser que des accessoires Probst d'origine, en cas de doute prendre contact avec le fabricant.



La **charge admissible** de l'appareil porteur /engin de levage ne doit pas être dépassée par la charge de l'appareil et des appareils rapportés (moteur vireur, poches à emboîter, potence etc.) ainsi que par la charge supplémentaire des objets à appréhender.

En général, le appareil doit être **suspendu par cardan** à la appareil de lavage/porteur, de manière à ce que le appareil raccordé puissent osciller librement avec n'importe quelle position.



En **peut en aucun cas** un appareil peut être monté rigide à de l'appareil porteur /engin de levage !

En cas d'entrave du mouvement d'oscillation, des contraintes peuvent apparaître et entraîner une rupture du appareil et du système de suspension. **La mort, des blessures graves et des dommages matériels peuvent en être la conséquence.**



Lors de l'utilisation de l'appareil sur des accessoires optionnels (tels que poche d'insertion, flèche de grue, etc.), il n'est pas exclu, en raison de la construction la plus basse possible de l'ensemble de l'appareil (pour éviter la perte de hauteur de levage), que l'appareil entre en collision avec des composants adjacents si l'appareil est suspendu de manière oscillante et positionné de manière défavorable lorsque le porteur se déplace. Cela doit être évité autant que possible en positionnant l'outil de manière appropriée et en conduisant de manière adéquate. Les dommages qui en résultent ne seront pas réglementés dans le cadre de la garantie.

4.1.1 Œillet d'accrochage / Boulon d'accrochage

L'appareil est équipé d'un œillet/boulon d'accrochage et peut donc être accroché aux appareils porteurs les plus divers.



Veiller à ce que l'œillet/le boulon d'accrochage soit relié sûrement au crochet de grue/de levage et ne puisse pas glisser.

4.1.2 Crochets de charge et dispositif d'élingage



- L'appareil est attaché à l'appareil porteur/de levage à l'aide d'un crochet de levage ou d'une dispositif d'élingage appropriée.
- **Il faut faire attention à ce que les différentes gaines de chaîne ne soient pas tordues ou nouées.**
- Lors de l'installation mécanique de l'appareil, il faut respecter les consignes de sécurité localement en vigueur.

4.1.3 Têtes rotatives (en option)



En cas d'utilisation de têtes rotatives, il est **impératif** de monter un **dispositif de régulation de roue libre**.

Pour qu'une accélération ou un arrêt brusque des mouvements de rotation soit exclu car ceux-ci pourraient sinon **détériorer** l'appareil en peu de temps.

4.1.4 Fourreaux (en option)

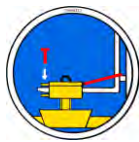

Pour établir une liaison sûre entre le chariot élévateur et la poche d'insertion (3), on introduit les dents du chariot élévateur (1) dans la poche d'insertion (3).

Ensuite, on les bloque soit au moyen de vis de blocage (2), qui sont introduites dans un trou à prévoir dans les dents du chariot élévateur (1), soit au moyen d'une chaîne ou d'une corde (4), qui doit être passée dans les œillets de la poche de rangement (3) et autour du tablier porte-fourche (↘).



Cet assemblage doit être mis en place afin d'éviter que le fourreau ne glisse des fourches du chariot lorsque celui-ci est en service. **RISQUE D'ACCIDENT!**

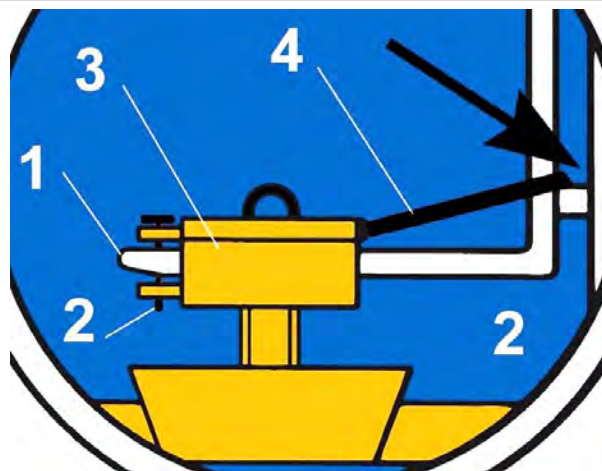
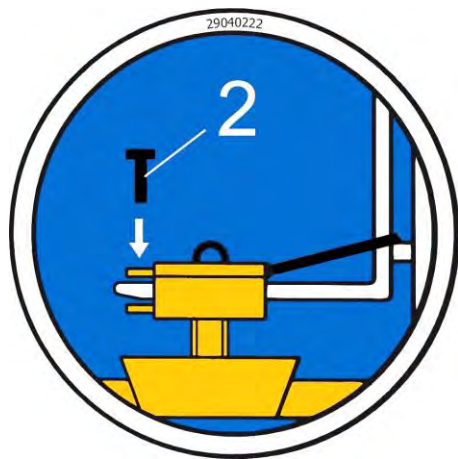

4.2 Montage des griffes de préhension en acier WB-SQ

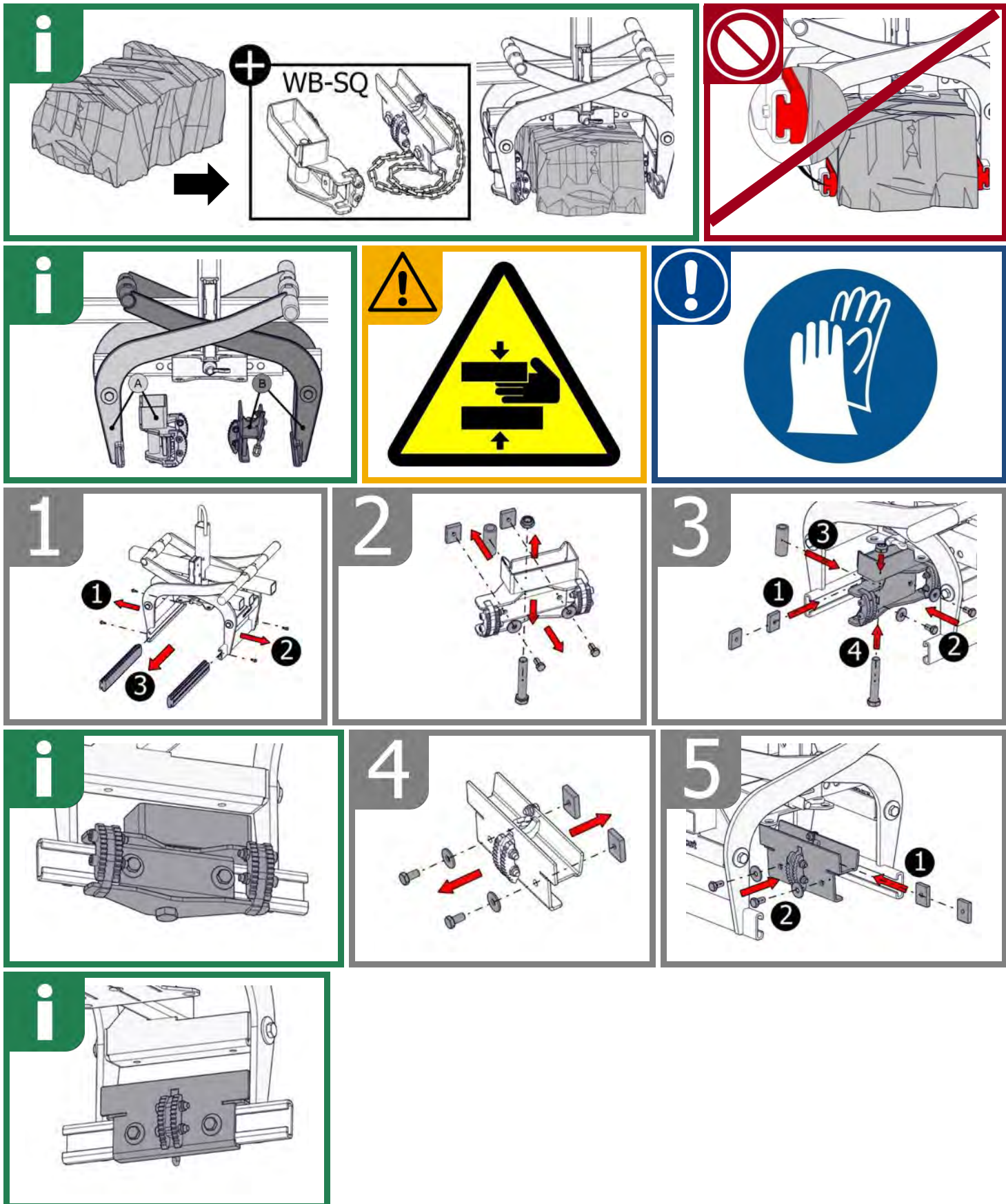

5 Réglage

5.1 Réglage de l'ouverture

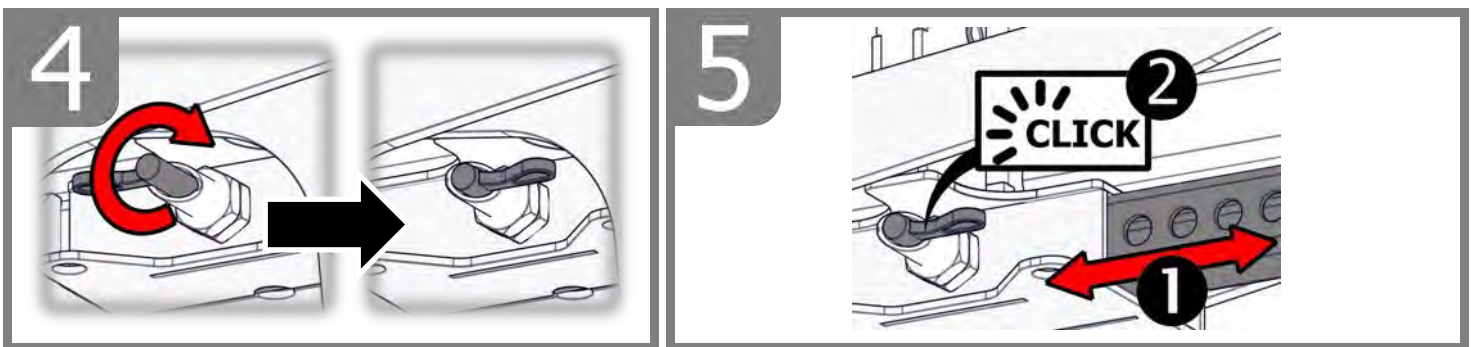
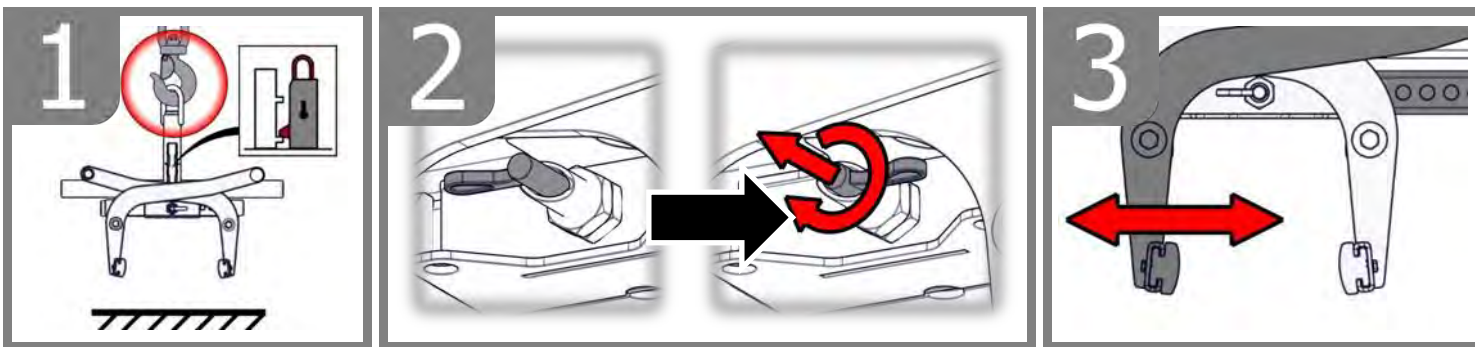
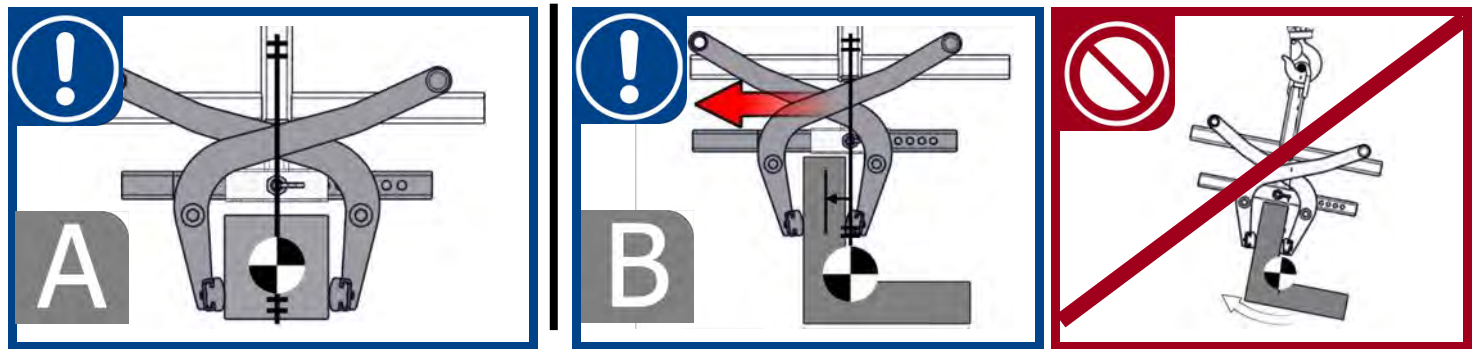
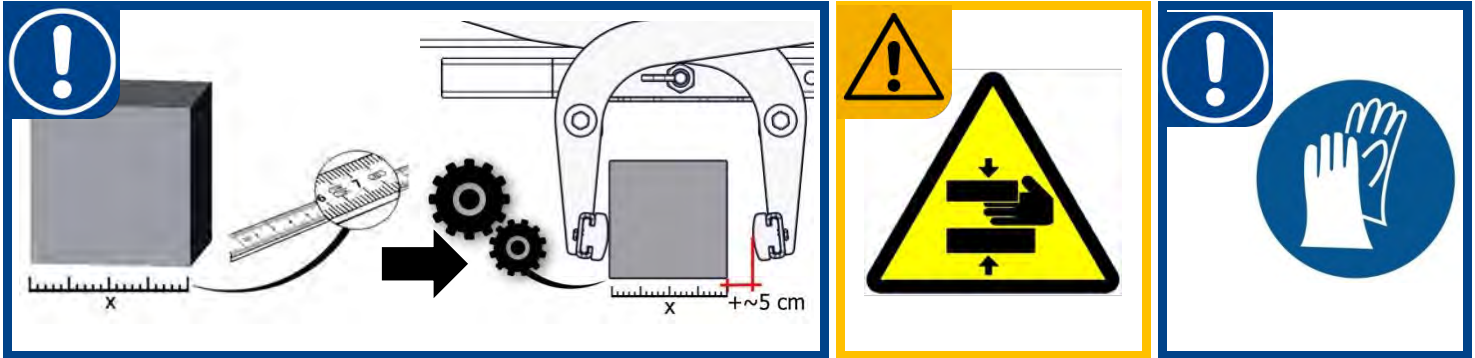

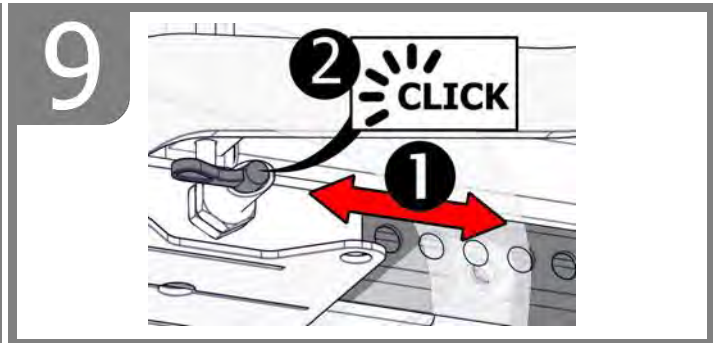
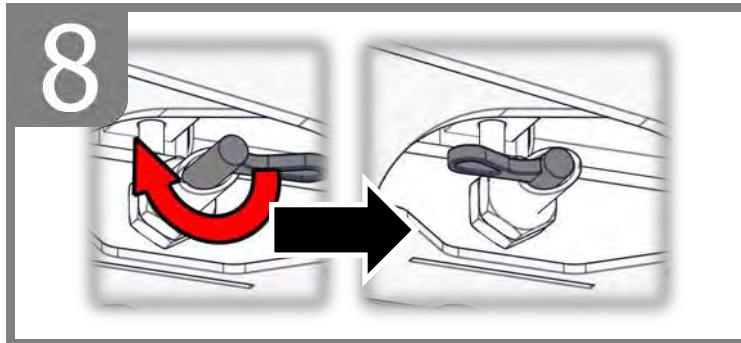
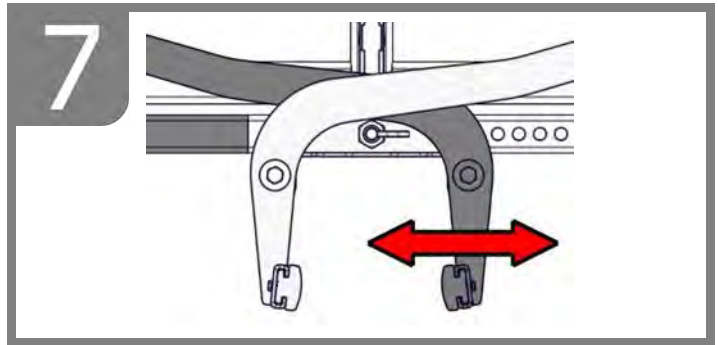
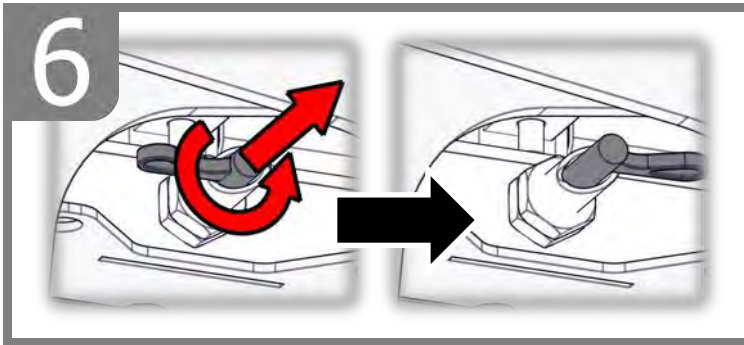

5.2 Accessoires - HVA pour fonctionnement par lots

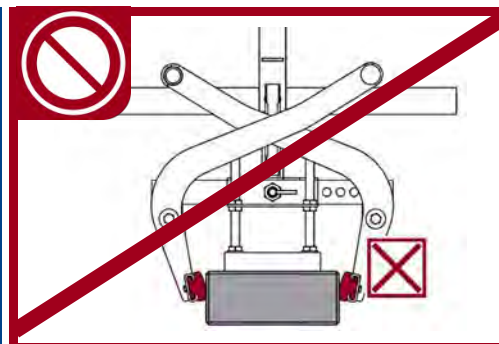
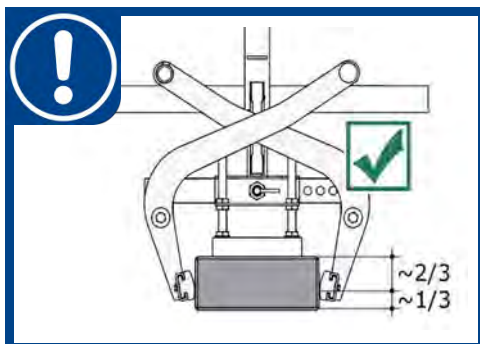
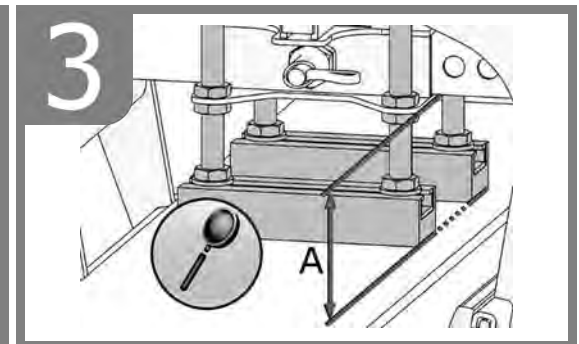
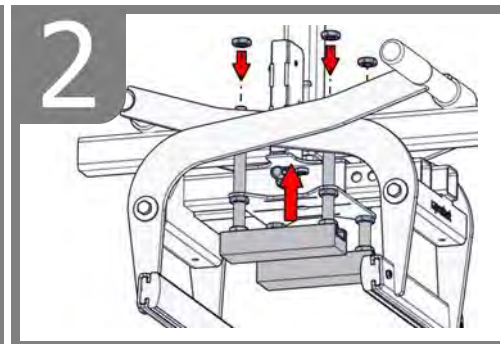
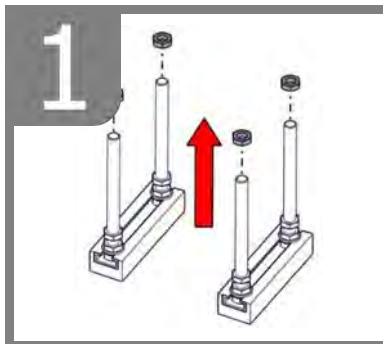
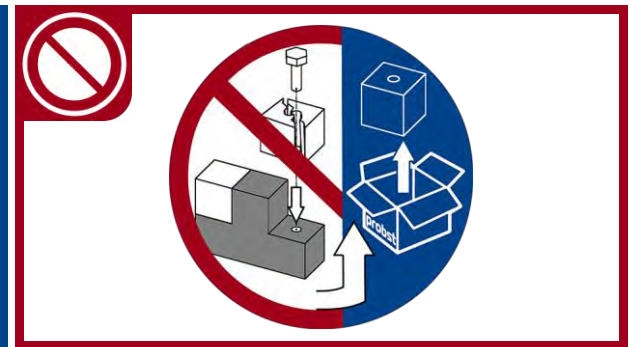
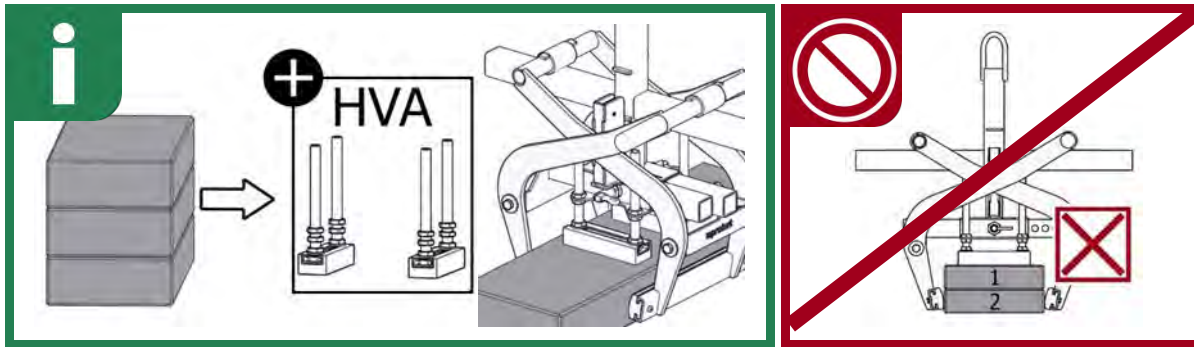

6 Maniement

6.1 Saisir, déplacer et déposer des charges

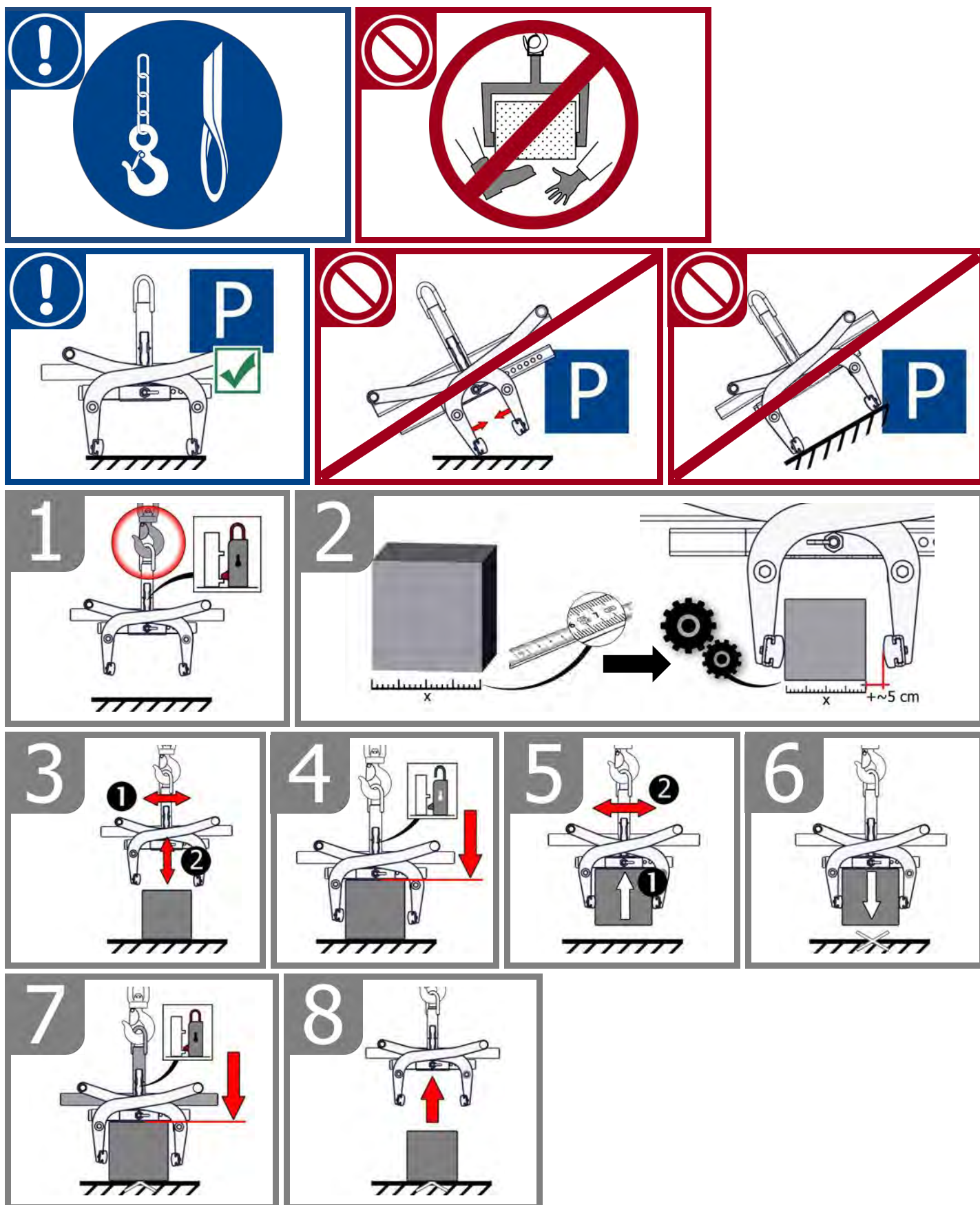

6.2 Images du système de changement automatique

L'appareil est équipé d'un système de commutation entièrement automatique, c'est-à-dire que l'OUVERTURE et la FERMETURE des bras de préhension s'opèrent par le dépôt et le soulèvement de l'appareil.

Représentations schématiques des positions de commutation du système automatique de changement.

<p>1</p> <ul style="list-style-type: none"> Appareil soulevé par appareil porteur. Bras de préhension ouverts. 	<p>2</p> <ul style="list-style-type: none"> Appareil déposé sur produit préhensible. Bras de préhension ouverts. 	<p>3A</p> <ul style="list-style-type: none"> Appareil soulevé par appareil porteur. Produit préhensible monté et en cours de transport vers le lieu de destination.
<p>3B</p> <ul style="list-style-type: none"> En cas de mauvaise commutation, le mécanisme doit être enfoncé à nouveau manuellement (par ex. à l'aide d'un tournevis). ¹⁾ 	<p>4</p> <ul style="list-style-type: none"> Appareil et produit manipulé déposés sur le sol. Bras de préhension ouverts. 	<p>5/1</p> <ul style="list-style-type: none"> Appareil soulevé par appareil porteur. Bras de préhension ouverts. (Position de repos de l'appareil sur le sol).



¹⁾ Sinon, il existe un risque de provoquer de faux contacts et par conséquent une déformation voire une destruction du mécanisme de changement lors de la dépose de la charge.
Il est interdit de lever ou abaisser brutalement l'appareil et de rouler à vitesse élevée avec l'engin de préhension/levage sur un terrain accidenté.



Lors du remplacement d'un système automatique de changement défectueux, les fentes des deux goupilles de serrage doivent **toujours** être orientées vers le bas.
 Les fentes ne doivent **en aucun cas** être orientées vers le haut ou vers le côté, car le système automatique de changement risque alors de se coincer pendant l'ouverture ou la fermeture des bras de préhension !

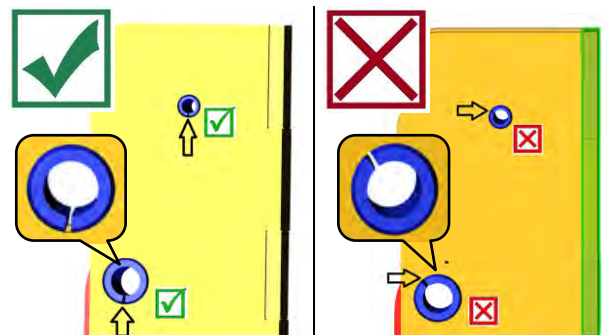

6.3 Fonctionnement : Griffes de préhension en acier WB-SQ

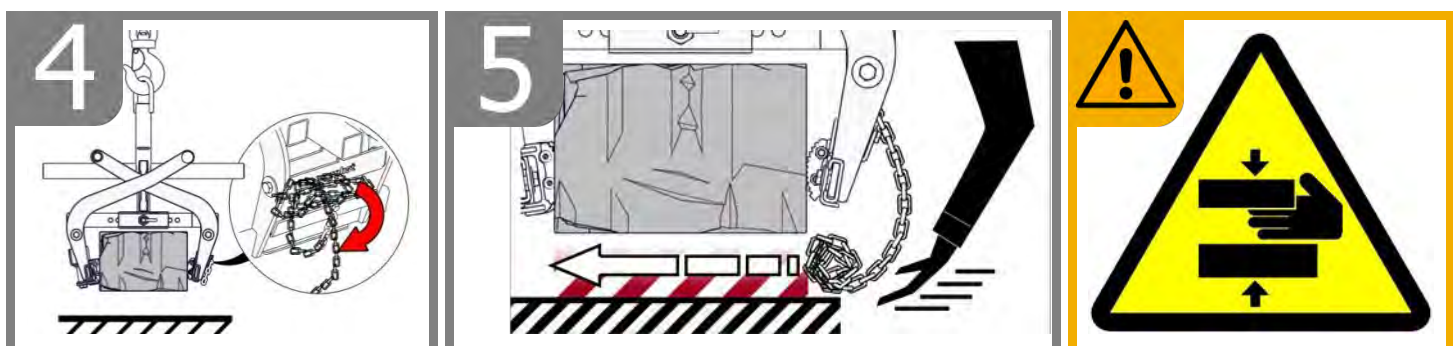
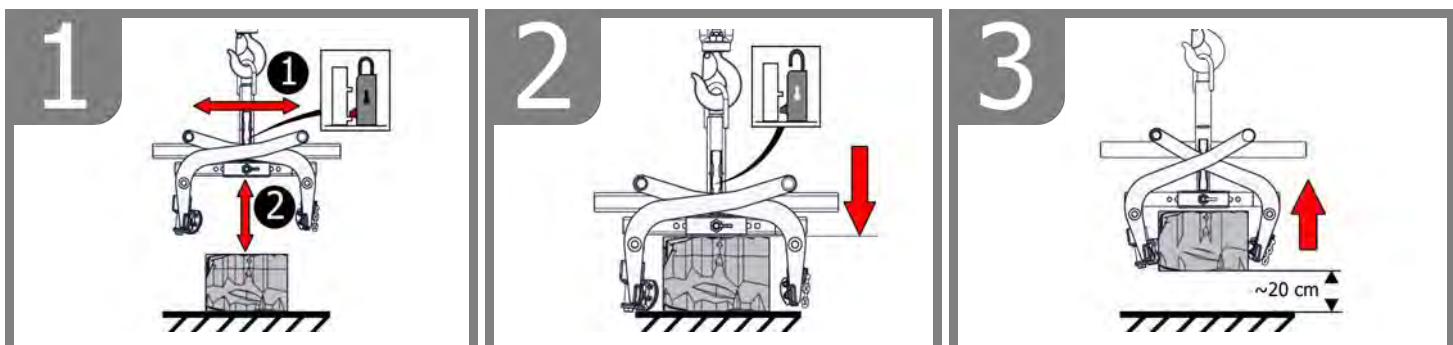
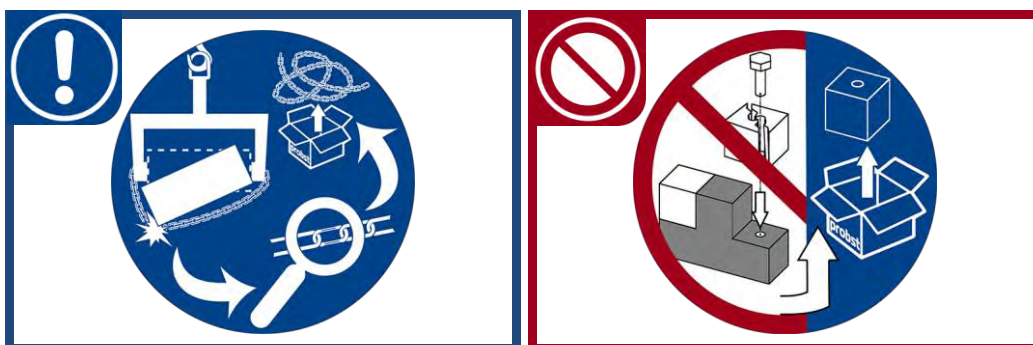
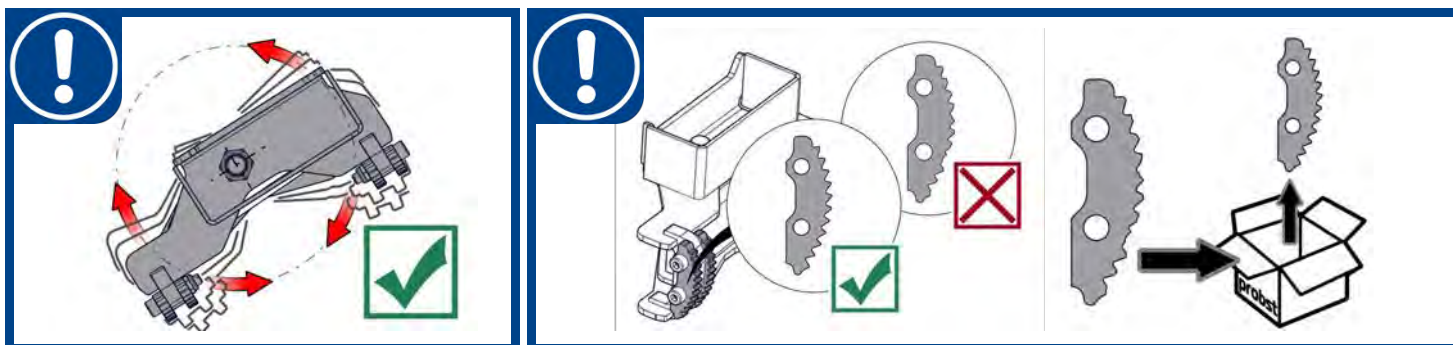

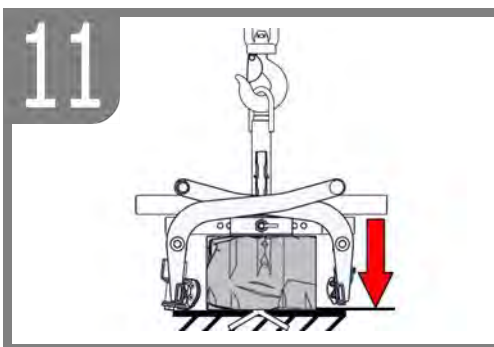
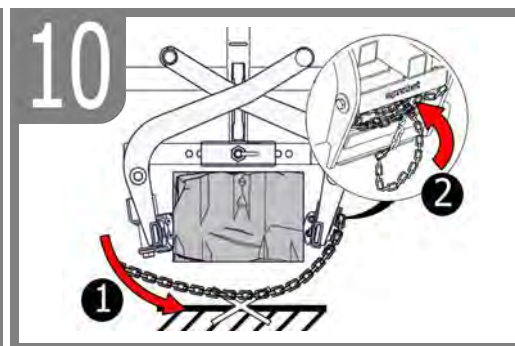
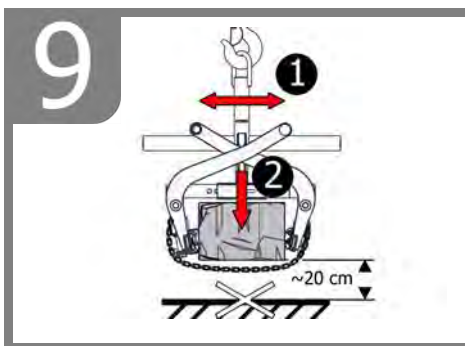
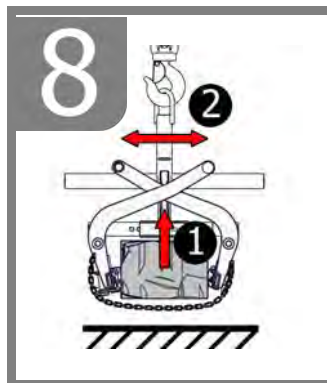
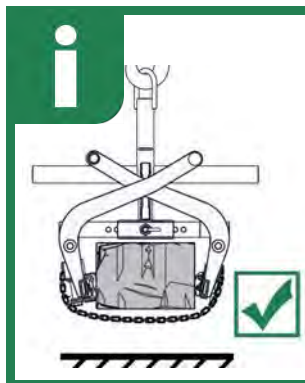
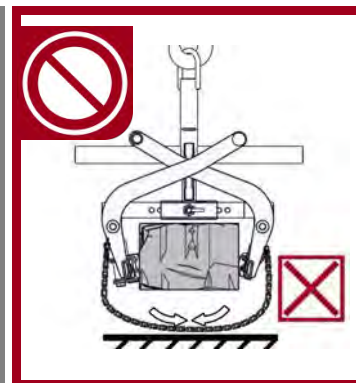
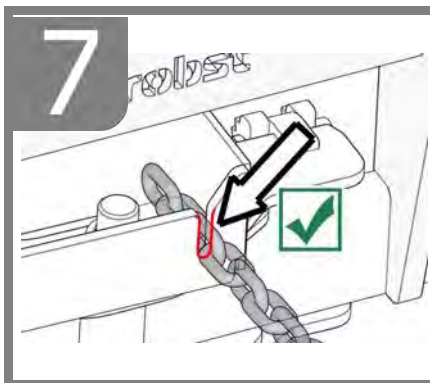
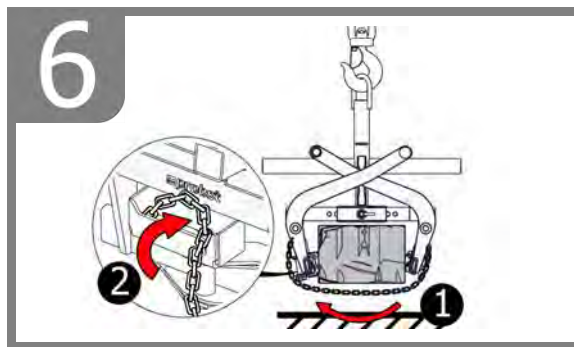

7 Maintenance et entretien

7.1 Maintenance



Pour que l'appareil fonctionne parfaitement, pour assurer sa sécurité de fonctionnement et une longue durée de vie, il est impératif d'effectuer les opérations de maintenance spécifiées dans le tableau ci-dessous aux intervalles prescrits.

Utiliser **exclusivement des pièces de rechange d'origine** ; la garantie ne s'applique pas dans le cas contraire.



Tenir compte du fait que tous les travaux effectués sur l'appareil impliquent systématiquement son arrêt !

Lors de tous les travaux, il faut s'assurer que l'appareil ne peut pas se fermer involontairement.

Risque de blessure !

7.1.1 Mécanique

DÉLAI DE MAINTENANCE	Travaux à réaliser
Inspection initiale après 25 heures de fonctionnement	<ul style="list-style-type: none"> • Vérifiez ou resserrez toutes les vis de fixation. (ne peut être effectuée que par une personne qualifiée).
Toutes les 50 heures de fonctionnement	<ul style="list-style-type: none"> • Resserrez toutes les vis de fixation (veillez à ce que les vis soient resserrées selon les couples de serrage valables des classes de résistance correspondantes). • Vérifiez le bon fonctionnement de tous les éléments de fixation existants (tels que les goupilles fendues articulées) et remplacez les éléments de fixation défectueux. 1) • Vérifiez le bon fonctionnement de tous les joints, guides, axes et engrenages, chaînes, réajustez ou remplacez-les si nécessaire. • Vérifiez l'usure des mâchoires de préhension (s'il y en a) et nettoyez-les, remplacez-les si nécessaire. • Graisser/lubrifier tous les guides coulissants, crémaillères, joints de pièces mobiles ou composants de machines existants pour réduire l'usure et pour un mouvement optimal (graisse recommandée : Mobilgrease HXP 462). • Lubrifiez tous les graisseurs (s'il y en a) avec un pistolet graisseur.
Au moins 1x par an (raccourcir l'intervalle d'essai dans des conditions de fonctionnement difficiles)	<ul style="list-style-type: none"> • Inspection de toutes les pièces de suspension, ainsi que des boulons et des oreilles. Inspection des fissures, de l'usure, de la corrosion et de la sécurité fonctionnelle par un expert.

1)

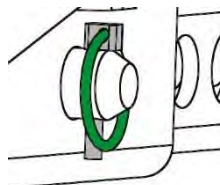

Mâchoires de préhension en caoutchouc



Contrôle régulier de l'absence de **salissures** (par exemple particules de pierre) dans la zone supérieure (voir le point zoomé « X » sur la fig. 2) des mâchoires de préhension en caoutchouc (6) → voir fig. 1 / fig. 2.

Problème : Les salissures peuvent endommager les mâchoires de préhension (6) lors d'un serrage dans cette zone (les particules de pierre peuvent s'incruster dans le caoutchouc).

Conseil : Retirer les salissures dans cette zone des mâchoires (6) ou, si les salissures sont importantes, démonter les mâchoires de préhension et les nettoyer.

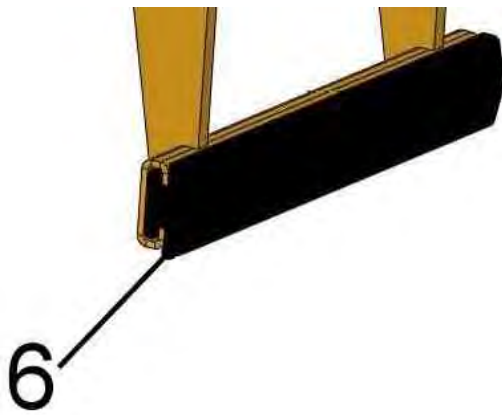

Fig. 1

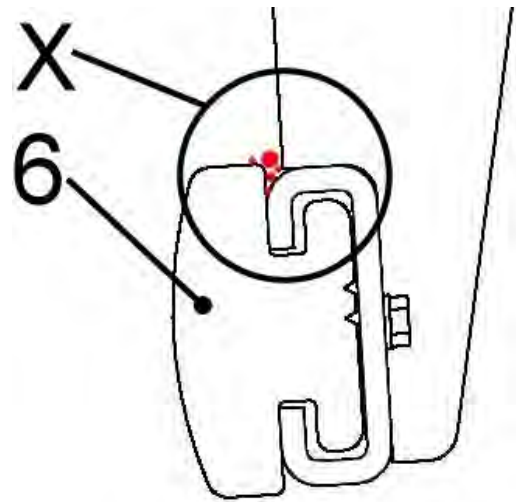

Fig. 2

7.1.2 En cas d'utilisation des griffes de préhension en acier (WB-SQ)

Avant chaque mise en service:

- Vérifier la mobilité, l'usure et la propreté des griffes de préhension en acier. Les griffes de préhension usées (qui ne sont plus acérées) ou tordues **doivent être remplacées** !

Régulièrement :

- Nettoyage de l'appareil avec un nettoyeur haute pression (eau chaude).

Chaque semaine :

- Graisser et lubrifier les éléments mobiles.

SYSTEME DE COMMUTATION ENTIEREMENT AUTOMATIQUE



Le système de commutation entièrement automatique ne doit **jamais** être lubrifié avec de la graisse ou d'huile !

Nettoyer tout encrassement visible avec un nettoyeur haute pression !

7.2 Élimination des dérangements

DÉRANGEMENT	CAUSE	DÉPANNAGE
La force de serrage est insuffisante, la charge glisse. (optional)	<ul style="list-style-type: none"> Les mâchoires sont usées. 	<ul style="list-style-type: none"> Remplacer les mâchoires.
(optional)	<ul style="list-style-type: none"> La charge est supérieure à celle autorisée. 	<ul style="list-style-type: none"> Réduire la charge
(Réglage de l'ouverture/ capacité de préhension) (optional)	<ul style="list-style-type: none"> L'ouverture/ capacité de préhension réglée n'est pas la bonne 	<ul style="list-style-type: none"> Régler l'ouverture/ capacité de préhension en fonction des matériaux à transporter.
(Propriétés du matériau)	<ul style="list-style-type: none"> La surface du matériau est sale ou le matériau n'est pas adapté / autorisé pour cet appareil. 	<ul style="list-style-type: none"> Contrôler la surface du matériau ou contacter le fabricant pour savoir si le matériau est autorisé pour cet appareil.
L'engin n'est pas droit		
	<ul style="list-style-type: none"> La pince est chargée unilatéralement. 	<ul style="list-style-type: none"> Répartir la charge de façon symétrique.
(Réglage de l'ouverture/ capacité de préhension)	<ul style="list-style-type: none"> L'ouverture / capacité de préhension n'est pas réglée de façon symétrique. 	<ul style="list-style-type: none"> Contrôler et rectifier le réglage de l'ouverture/ capacité de préhension.
Le fonctionnement des griffes n'est pas synchrone		
(Compensateur de crémaillère)	<ul style="list-style-type: none"> Le compensateur de crémaillère est défectueux 	<ul style="list-style-type: none"> Contrôler et réparer le compensateur de crémaillère
Le système de commutation entièrement automatique ne fonctionne pas		
Mécanique (en option)	<ul style="list-style-type: none"> Le système de commutation entièrement automatique ne fonctionne pas 	<ul style="list-style-type: none"> Nettoyer le système de commutation entièrement automatique au jet de vapeur Corriger la mauvaise commutation (→ voir chapitre « Représentation du système de commutation entièrement automatique ») Échanger l'insert du système de commutation entièrement automatique.

7.3 Réparations



- Seul un personnel disposant des connaissances et des compétences nécessaires est autorisé à effectuer des réparations sur l'appareil.
- Avant la remise en service, un contrôle extraordinaire **doit être** effectué par un spécialiste ou un expert.

7.4 Devoir de contrôle



- L'entrepreneur doit veiller à ce que l'appareil soit contrôlée au moins une fois par an par un expert, et à ce que les déficiences constatées soient réparées immédiatement (→ norme DGUV 100-500).
- Observer les prescriptions correspondantes des associations professionnelles déclaration de conformité.
- Le contrôle expert peut également être effectué par le fabricant Probst GmbH.
Contactez-nous à : service@probst-handling.de
- Lorsqu'un contrôle a été effectué et que les déficiences ont été réparées sur l'appareil, nous conseillons d'apposer la plaquette „CONTRÔLE DE SÉCURITÉ“ bien lisiblement sur l'appareil (No de commande: 2904.0056+vignette du contrôle technique avec date).



La vérification par un expert doit être impérativement documentée.

Appareil	Année	Date	Expert	Société

7.5 Informations concernant la plaque signalétique



- Le type et le numéro de l'appareil ainsi que l'année de construction sont des informations importantes pour identifier l'appareil. Elles doivent toujours être indiquées pour des commandes de pièces de rechange, des demandes de garantie et d'autres questions en liaison avec l'appareil.
- La charge maximale indique la capacité de charge maximale (WLL) pour laquelle l'appareil est conçu. La charge maximale (WLL) **ne doit** pas être dépassée.
- Le poids propre défini sur la plaque signalétique doit être pris en compte lors de l'utilisation avec un engin de levage / engin porteur (par ex. grue, palan, chariot élévateur, excavateur ...).



Exemple:

7.6 Remarque concernant la location/le prêt des engins PROBST



Lors de chaque location/prêt d'un engin PROBST, les **instructions d'emploi originales** correspondantes **doivent impérativement** être jointes (si la langue n'est pas celle de l'utilisateur, une traduction des instructions d'emploi originales dans la langue adéquate doit être fournie) !

8 Elimination / recyclage des appareils et des machines



Le produit **ne doit être** mis hors service et préparé pour l'élimination / le recyclage que par un personnel qualifié. Les **composants individuels** présents (tels que les métaux, les plastiques, les liquides, les piles/accumulateurs, etc.) **doivent être** éliminés/recyclés conformément aux lois et aux **réglementations nationales/locales en vigueur en matière d'élimination des déchets!**



Le produit ne doit pas être éliminé avec les ordures ménagères!

Preuve de maintenance



La garantie ne peut s'appliquer pour cet appareil qu'à condition que les travaux de maintenance prévus aient été effectués (par un atelier spécialisé et autorisé) ! Après la réalisation de travaux de maintenance périodiques, il faudra nous transmettre sans délai la présente attestation de maintenance (signée et revêtue de votre cachet). ¹⁾

¹⁾ par email à: service@probst-handling.de / par fax ou par courrier.

Opérateur: _____
 Modèle: _____ N° de commande.: _____
 N° de appareil: _____ Année de construction: _____

Première inspection après 25 heures de service		
Date:	Opérations à effectuer:	Maintenance de firme:
		<i>Pistil</i>
	
		Nom / Nom

Toutes les 50 heures de service		
Date:	Opérations à effectuer:	Maintenance de firme:
		<i>Pistil</i>
	
		Nom / Nom
		Maintenance de firme:
		<i>Pistil</i>
	
		Nom / Nom
		Maintenance de firme:
		<i>Pistil</i>
	
		Nom / Nom

Au minimum 1 fois par an		
Date:	Opérations à effectuer:	Maintenance de firme:
		<i>Pistil</i>
	
		Nom / Nom
		Maintenance de firme:
		<i>Pistil</i>
	
		Nom / Nom

TSZ-UNI



NL | Bedrijfshandleiding

Inhoud

1	CE - Conformiteitsverklaring	3
2	Veiligheid	4
2.1	Veiligheidsinstructies.....	4
2.2	Definities van termen.....	4
2.3	Definitie van gekwalificeerd personeel / deskundige	4
2.3.1	Verklaring van de pictogrammen	5
2.4	Veiligheidsaanduidingen	6
2.5	Persoonlijke veiligheidsmaatregelen	7
2.6	Beschermende uitrusting.....	7
2.7	Ongevallenpreventie	7
2.8	Functionele en visuele controle	7
2.8.1	Algemeen.....	7
2.9	Veiligheid tijdens bedrijf.....	8
2.9.1	Algemene informatie	8
2.9.2	Draagmachines/hefwerktuigen.....	8
3	Algemeen	9
3.1	Gebruik volgens de voorschriften	9
3.2	Overzicht en opbouw.....	11
3.3	Accessoires	11
3.4	Technische gegevens	11
4	Installatie	12
4.1	Mechanische montage	12
4.1.1	Inhangooeg / Inhangbout	12
4.1.2	Lasthaak en draagdoek.....	12
4.1.3	Draaikoppen (optioneel).....	12
4.1.4	Aan de machine gebouwde constructie met insteekzakken (option).....	13
4.2	Montage van de stalen grijpklaauwen WB-SQ	14
5	Afstelwerkzaamheden	15
5.1	Instelling van de openingsbreedte.....	15
5.2	Accessoires - HVA voor seriematige werking.....	17
6	Bediening	18
6.1	Het grijpen, verplaatsen en deponeren van lasten	18
6.2	Afbeelding van de wisselautomaat	19
6.3	Bediening: Stalen grijpklaauwen WB-SQ	20
7	Onderhoud en verzorging	22
7.1	Onderhoud	22
7.1.1	Mechanica.....	22
7.1.2	Meer informatie over de stalen grijpvlak (WB-SQ)	23
7.2	Verhelpen van storingen	24
7.3	Reparaties	24
7.4	Controleplicht	25
7.5	Instructie m.b.t. het typeplaatje.....	26
7.6	Instructie m.b.t. verhuur/uitlenen van PROBST apparaten.....	26
8	Verwijdering / recycling van apparatuur en machines	26

Wijzigingen van de informatie en afbeeldingen in de gebruiksaanwijzing voorbehouden.

1 CE - Conformiteitsverklaring

Benaming: Tang voor het leggen van trappen TSZ
Typ: TSZ-UNI
Bestel-Nr.: 53100338



Fabrikant: Probst GmbH
Gottlieb-Daimler-Straße 6
71729 Erdmannhausen, Germany
info@probst-handling.de
www.probst-handling.com

De hierboven beschreven machine voldoet aan de betreffende bepalingen van de volgende Europese richtlijnen:

2006/42/EG (machinerichtlijn)

De volgende normen en technische specificaties zijn gebruikt:

DIN EN ISO 12100

Veiligheid van machines - Algemene ontwerpbeginsselen – Risicobeoordeling en risicoreductie

DIN EN ISO 13857

Zekerheid van machines — Zekerheidsafstand voor het vermijden van gevaarlijke delen met het boven en onder lichaam

Autoriseerde persoon voor EC-dokumentatie:

Naam: Jean Holderied
Adres: Probst GmbH; Gottlieb-Daimler-Straße 6; 71729 Erdmannhausen, Germany

Handtekening, gegevens over ondertekenaar:

Erdmannhausen, 28.06.2023.....
(Eric Wilhelm, Managing Director)



2 Veiligheid

2.1 Veiligheidsinstructies



Sterfelijk gevaar!

Geeft een gevaar aan. Als dit niet wordt vermeden, zijn de dood en ernstige verwondingen het gevolg.



Gevaarlijke situatie!

Geeft een gevaarlijke situatie aan. Als dit niet wordt vermeden, kan dit leiden tot letsel of schade aan eigendommen.



Verbod!

Dat duidt op een verbod. Het niet naleven ervan zal leiden tot de dood, ernstig letsel of schade aan eigendommen.



Belangrijke informatie of nuttige tips voor het gebruik.

2.2 Definities van termen

Grijp bereik:	<ul style="list-style-type: none"> • geeft de minimale en maximale productafmetingen aan van het product dat met dit apparaat moet worden vastgepakt.
Grijpwaar (grijpwaaren):	<ul style="list-style-type: none"> • is het product dat wordt vastgepakt of getransporteerd.
Openingsbreedte:	<ul style="list-style-type: none"> • is samengesteld uit het grijpbereik en de instapdimensie. <i>$grijpbereik + ingangsafmeting = openingsbereik$</i>
Dompeldiepte:	<ul style="list-style-type: none"> • komt overeen met de maximale grijphoogte van de grijpgoederen, vanwege de hoogte van de grijparmen van het apparaat.
Apparaat:	<ul style="list-style-type: none"> • is de aanduiding voor de grijper.
Productafmeting:	<ul style="list-style-type: none"> • zijn de afmetingen van de te grijpen goederen (bijv. lengte, breedte, hoogte van een product).
Dood gewicht:	<ul style="list-style-type: none"> • is het leeggewicht (zonder grijpermateriaal) van het apparaat.
Belastingscapaciteit (WLL *):	<ul style="list-style-type: none"> • geeft de maximaal toelaatbare belasting van het apparaat aan (voor het heffen van grijpgoederen). *= WLL → (Engels:) <u>Working Load Limit</u>
Gebied dicht bij de grond:	<ul style="list-style-type: none"> • de grijpwaar moet onmiddellijk na het opnemen (b.v. van een pallet of een vrachtwagen) tot vlak boven de grond (ca. 0,5 m) worden neergelaten. Til de grijpwaar voor het transport slechts zo hoog op als nodig is (aanbeveling ca. 0,5 m boven de grond).

2.3 Definitie van gekwalificeerd personeel / deskundige

Installatie-, onderhouds- en reparatiewerkzaamheden aan dit apparaat mogen alleen door gekwalificeerd personeel of deskundigen worden uitgevoerd!

Gekwalificeerd personeel of deskundigen moeten over de nodige vakkennis beschikken op de volgende gebieden, voor zover van toepassing op dit toestel:

- voor monteurs
- voor hydrauliek
- voor pneumatiek
- voor de elektra

2.3.1 Verklaring van de pictogrammen

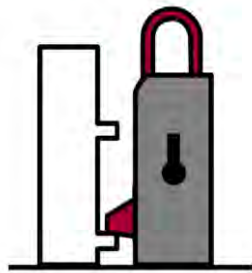

Automatische wisselautomaat gesloten

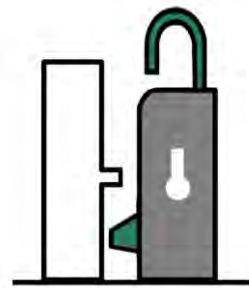

Automatische wisselautomaat open

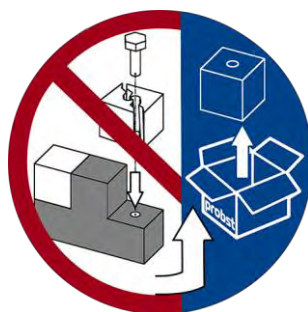

Gebruik geen beschadigde accessoires, vervang deze indien nodig!



Houd de ledematen niet onder de gehesen last!
Gevaar voor letsel!



Toegestane draagbanden: haak en hijsband.





De ladingbeveiligingsketting (sjorketting) mag niet als stropketting worden gebruikt!
De lastketting kan breken en de lading zou neerstorten!
Gevaar voor letsel en dood!



Als de lading in de lastborgingsketting valt, moet de ketting professioneel worden gecontroleerd en indien nodig worden vervangen.
Gebruik geen beschadigde lastborgingsketting meer!

2.4 Veiligheidsaanduidingen



VERBODSTEKENS

Symbool	Betekenis	Bestel-Nr.	Formaat
	Nooit onder een zwevende last gaan staan. Levensgevaar!	29040210 29040209 29040204	Ø30 mm Ø50 mm Ø80 mm
	Er mogen geen kegelvormige goederen worden vastgepakt.	29040213 29040212 29040211	Ø 30 mm Ø 50 mm Ø 80 mm
	Neem nooit ladingen uit het midden op, altijd in het zwaartepunt van de lading.	29040216 29040215 29040214	Ø 30 mm Ø 50 mm Ø 80 mm

WAARSCHUWINGEN

Symbool	Betekenis	Bestelnummer:	Formaat:
	De handen kunnen vastgeklemd raken.	2904.0221 2904.0220 2904.0107	30 x 30 mm 50 x 50 mm 80 x 80 mm

GEBODSTEKENS

Symbool	Betekenis	Bestel-Nr.	Formaat
	Elke bediener moet de handleiding met de veiligheidsvoorschriften van het toestel gelezen en begrepen hebben.	29040665 29040666 29041049	Ø 30 mm Ø 50 mm Ø 80 mm
	Handmatige geleiding van het apparaat is alleen toegestaan op de rode handgrepen.	29040227 29040226 29040225	Ø 30 mm Ø 50 mm Ø 80 mm

OPTIONEEL

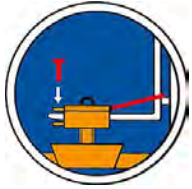
	Zet de insteekzak en de vorkheftrucktanden vast met een borgschroef en een veiligheidsketting of -touw.	29040223 29040222	Ø 50 mm Ø 80 mm
---	---	----------------------	--------------------

2.5 Persoonlijke veiligheidsmaatregelen



- Elk persoon die het apparaat bedient moet van tevoren de bedieningshandleiding voor de Easy Clean met de veiligheidsvoorschriften hebben gelezen en begrepen.
- Het apparaat en alle daarmee verbonden apparaten die in het apparaat in/aangebouwd zijn, mogen enkel door door personeel worden bediend die hiervoor gekwalificeerd en gecertificeerd zijn.



- Er mogen enkel machines met **handgrepen handmatig bedient** worden.
Anders bestaat er gevaar voor verwonding van de handen!

2.6 Beschermende uitrusting

De beschermende uitrusting bestaat volgens de veiligheidstechnische eisen uit:

- Beschermende kleding
- Veiligheidshandschoenen
- Veiligheidsschoenen

2.7 Ongevallenpreventie



- Beveilig het werkgebied voor onbevoegden, vooral kinderen, over een groot gebied.
- **Voorzichtig bij onweer - gevaar door blikseminslag!**
Stop, afhankelijk van de intensiteit van het onweer, zo nodig met het werken met de apparatuur.



- Verlicht het werkgebied voldoende.
- **Wees voorzichtig met natte, bevroren, ijzige en vuile bouwmaterialen!**
Het gevaar bestaat dat het grijpmateriaal eruit glijdt. GEVAAR VOOR ONGELUK!

2.8 Functionele en visuele controle

2.8.1 Algemeen



- Voor elk gebruik op werking moet gecontroleerd worden of het toestel goed functioneert en of het zich in goede staat bevindt.
- Onderhoud, smering en opheffen van storingen aan het toestel mogen uitsluitend buiten bedrijf plaatsvinden!



- Bij gebreken die de veiligheid betreffen, mag het toestel pas nadat de gebreken volledig zijn verholpen weer in gebruik worden genomen.
- In geval van scheuren, kieren of beschadigingen aan gelijk welke delen van het apparaat moet elke gebruik van het apparaat **onmiddellijk** stop gezet worden.



- De handleiding van het toestel moet op de werklocatie altijd kunnen worden geraadpleegd.
- De op het toestel aangebrachte typeplaatje mag niet worden verwijderd.
- Onleesbare verwijzingsplaatjes (zoals verbods- en waarschuwingstekens) moeten worden vervangen.

2.9 Veiligheid tijdens bedrijf

2.9.1 Algemene informatie



- Werkzaamheden met het apparaat mogen alleen worden uitgevoerd in een gebied dicht bij de grond. Het is verboden om het apparaat over personen heen te zwaaien.
- Het is verboden om onder een hangende lading te blijven. Gevaar voor het leven!



- Handbegeleiding is alleen toegestaan voor apparaten met handgrepen.



- Tijdens de werking is het verboden voor personen om in het werkgebied te verblijven! Tenzij het essentieel is, vanwege de aard van de toepassing van het apparaat, bijvoorbeeld door het apparaat handmatig te geleiden (door middel van handgrepen).
- Het schoksgewijs heffen of laten zakken van het werktuig met of zonder last is **verboden**, evenals het snel rijden met de drager/hijsinrichting over oneffen terrein! Rijd in het **algemeen met geheven** last met de drager/hijsinrichting (bv. graafmachine) slechts stapvoets - vermijd onnodige trillingen. **Gevaar**: De lading kan naar beneden vallen of de lastopnamemiddelen kunnen beschadigd raken!



- Neem de goederen nooit excentrisch op (altijd in het zwaartepunt van de lading), anders bestaat er gevaar voor kantelen.



- Het apparaat mag niet worden geopend als de openingsbaan wordt geblokkeerd door een weerstand.



- Het draagvermogen en de nominale breedte van het apparaat mogen niet worden overschreden.
- De bediener mag het controlestation niet verlaten zolang het apparaat geladen is met lading en moet de lading altijd in het zicht houden.n.
- Scheur geen vastzittende lading met het apparaat af.
- Trek of versleep ladingen nooit onder een hoek. Anders zouden delen van het apparaat beschadigd kunnen raken (zie Afb. A).

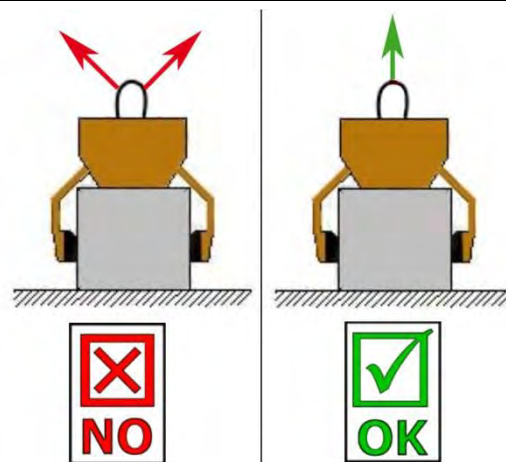

Afb. A

2.9.2 Draagmachines/hefwerktuigen



- De ingezette draagmachine/hefwerktuigen (bv. graafmachine) moet zich in een bedrijfsveilige toestand bevinden.
- De bediener van de draagmachine/hefwerktuigen moet aan de wettelijk voorgeschreven kwalificaties voldoen.
- Alleen geïnstrueerde, gekwalificeerde en gecertificeerde personen mogen de draagmachine/hefwerktuigen bedienen.



De maximaal toegestane draaglast van de draagmachine / hefwerktuigen en de draagdoek mag in geen geval overschreden worden!

3 Algemeen

3.1 Gebruik volgens de voorschriften

Het toestel (TSZ-UNI) mag uitsluitend gebruikt worden voor het grijpen, transporteren en verplaatsen van materialen zoals stenen traptreden, boordstenen, hoekstenen of andere blokken steen (door het monteren van optionele accessoire de *WB-SQ stalen grijpvlak*) met een bijhorend hef-/draagtoestel (bv. graafmachine).



- Het apparaat mag uitsluitend voor het in de handleiding omschreven voorgeschreven gebruik met inachtneming van de geldige veiligheidsvoorschriften en de desbetreffende wettelijke bepalingen en de bepalingen van de conformiteitsverklaring worden gebruikt.
- Elk ander gebruik geldt als niet conform de voorschriften en is **verboden!**
- De op de plaats van gebruik geldende wettelijke veiligheids- en ongevalpreventievoorschriften moeten bovendien worden aangehouden.



De gebruiker moet voor elk gebruik zeker zijn dat:

- het toestel geschikt is voor de voorziene toepassing
- dat het zich in de juiste stand bevindt
- dat de te heffen lasten mogen gehoffen worden

In geval van twijfel contacteert u best de fabrikant voor in gebruikname van het toestel.



OPGELET: Gebruik van het apparaat alleen op lage hoogte in de buurt van de bodem (→ hoofdstuk „Veiligheid tijdens bedrijf“ en “Definities van termen”)!



Er mogen **uitsluitend** steenelementen met parallelle en egale grijpvlakken worden gegrepen! Anders bestaat **gevaar voor afglijden!**



NIET TOEGESTANE ACTIVITEITEN:

Ongeoorloofde wijzigingen aan het toestel of het gebruik van zelfgemaakte extra voorzieningen brengen het leven van personen in gevaar en zijn daarom ten strengste **verboden!**

De draagvermogens (WLL) van het toestel mogen **niet** worden overschreden en **de nominale breedten/grijperbereiken mogen niet worden overschreden of niet worden onderschreden.**

Alle niet-beoogde transporten met het toestel zijn **ten strengste verboden:**

- het vervoer van mensen en dieren.
- het grijpen en transporteren van bouwpakketten, voorwerpen en materialen die niet in deze gebruiksaanwijzing zijn beschreven.
- lasten aan de eenheid op te hangen met touwen, kettingen en dergelijke, behalve aan de daarvoor bestemde ophangogen/bouten.
- het vastgrijpen van goederen met verpakkingsfolie, omdat het risico bestaat **dat ze wegglijden.**
- het grijpen van goederen met een oppervlak dat de wrijvingscoëfficiënt verlaagt (bijv. geschuurde, behandelde, vuile, bevroren, gecoate, geverfde oppervlakken), aangezien hierdoor de wrijvingscoëfficiënt tussen de grijpbekken en de gegrepen goederen wordt verlaagd - **→kans op uitglijden!**
Remedie: Als de grijpbekken en het oppervlak van de producten in de buurt van de grijpbekken op een of andere manier vuil zijn, moeten ze absoluut **voor elk** grijpproces worden gereinigd!
- grijpgoederen die door de klemkracht van het grijpgereedschap kunnen vervormen of breken!
- grijpen van goederen die zichtbare schade vertonen of onder hun eigen gewicht kunnen breken.
- het vastgrijpen en vervoeren van kegelvormige en rond gegripte goederen, omdat het risico bestaat dat ze wegglijden. (Illustratie rechts)
- Steenlagen die "voeten", "buiken" of "blinde afstandhouders" hebben.

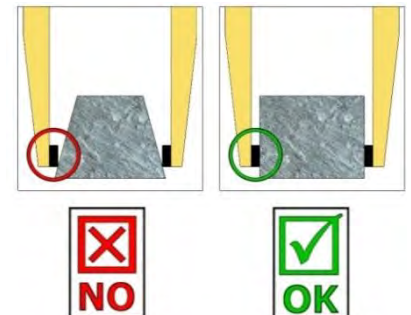

3.2 Overzicht en opbouw

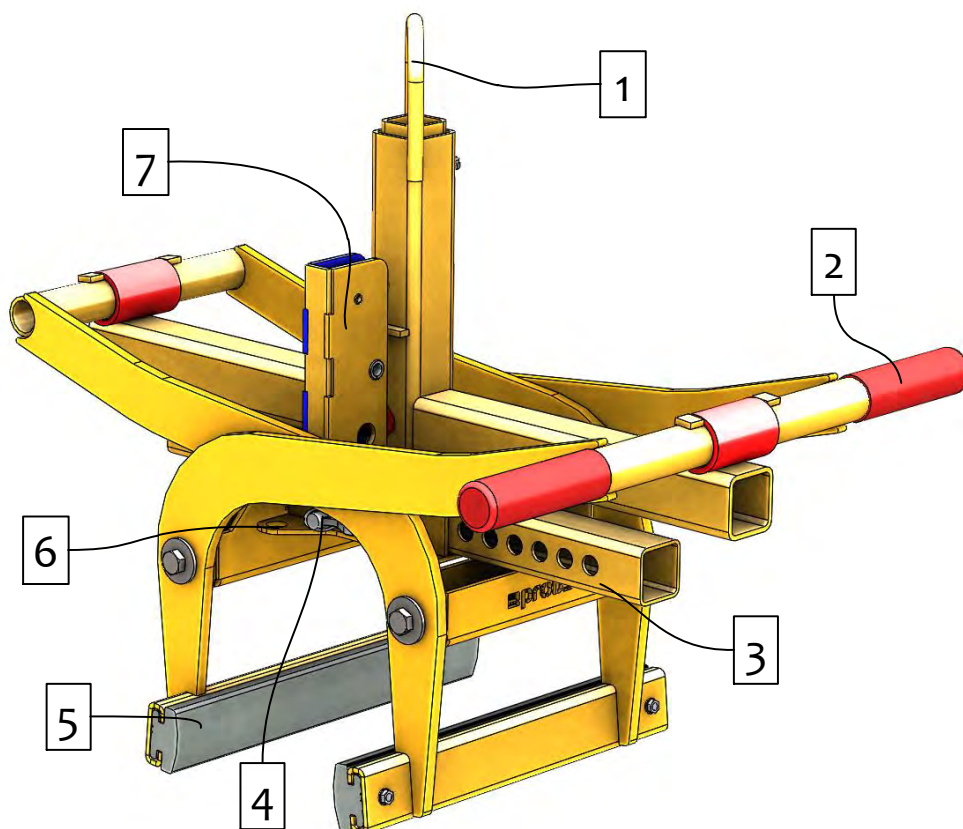

1	Inhangogen voor draagapparaat
2	Handgreep voor de geleiding van het apparaat
3	Aanpassing van het grijpbereik
4	Vergrendeling (aanpassing van het grijpbereik)
5	Gummigrijper
6	Montageplaat voor HVA
7	Wisselautomaat voor het volautomatisch omschakelen van "grijpen" naar "loslaten".

3.3 Accessoires



HVA-FTZ/TSZ
Leggen in batch-modus

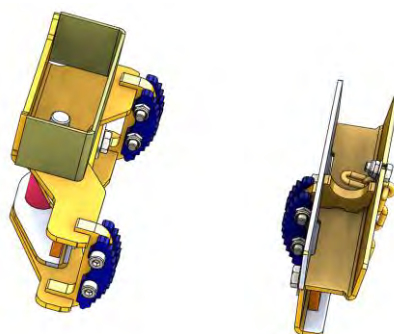

TSZ-UNI-WB-SQ
Greifen von roh behauenen Steinen

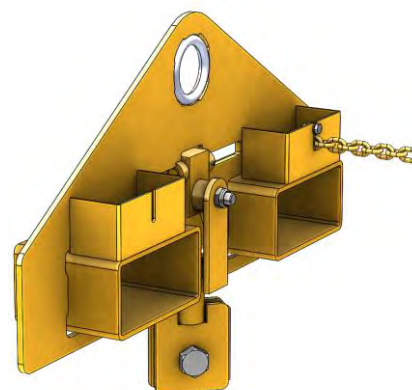

TSZ-UNI-ET
Insteezakken

3.4 Technische gegevens

De precieze technische gegevens (zoals draagvermogen, eigengewicht enz.) kunt u aan het bijgevoegde typeplaatje.

4 Installatie

4.1 Mechanische montage

Gebruik alleen origineel Probst-toebehoren en overleg bij twijfel met de fabrikant.



Het **draagvermogen** van het draagapparaat/hefgereedschap mag **niet** door de last van het apparaat, de aangebouwde machines (roterende motor, insteektassen, etc.) en de extra last van de grijpgoederen **overschreden** worden!

Grijpparamenten moeten **altijd cardanisch** worden opgehangen, zodat ze in elke positie vrij kunnen schommelen.



De grijpparamenten mogen **nooit rigide** met het hefgereedschap/draagapparaat worden verbonden! **Als wordt voorkomen dat het vrij schommelt, kunnen belastingen optreden, die tot breuk/beschadigingen van de ophanging en/of delen van het apparaat kunnen leiden.**

4.1.1 Inhangooog / Inhangbout

Het apparaat is voorzien van een inhangooog / inhangbout en kan hiermee aan zeer uiteenlopende draagparamenten/hefwerktuigen worden aangebracht.



Er moet worden opgelet dat het inhangooog / inhangbout veilig verbonden is met de aanslagmiddel (kraanhaak, mof enz.) aan hefgereedschap (bv. bagger). en niet omlaag kan glijden.

4.1.2 Lasthaak en draagdoek

Het apparaat wordt met een lasthaak of meet een geschikte draagdoek aan het draagapparaat/hefwerktuigen aangebracht.



Er moet op worden gelet dat de afzonderlijke kettingstrengen niet verdraaid zijn of in de knoop zitten.

Bij de mechanische installatie van het apparaat moet erop gelet worden dat alle plaatselijke veiligheidsvoorschriften opgevolgd worden.

4.1.3 Draaikoppen (optioneel)



Als er draaikoppen worden gebruikt, **moet** er een **vrijloopklep** aanwezig zijn.

Om te voorkomen dat draaibewegingen met schokken versnellen en stoppen. Het apparaat kan anders heel snel **beschadigd** raken.

4.1.4 Aan de machine gebouwde constructie met insteekzakken (option)

Om een veilige verbinding tussen de vorkheftruck en de inschuifruimte (3) tot stand te brengen, worden de heftrucktanden (1) in de inschuifruimte (3) gestoken.

Ze worden dan vergrendeld met borgschroeven (2), die door een gat in de heftand (1) worden gestoken, of met een ketting of touw (4), die door de oogjes van de insteekzak (3) en rond de vorkenwagen (↘) moet worden geleid.



Deze verbinding moet tot stand gebracht worden omdat anders de insteekzak bij het optillen van de vorken van de heftruck kan glijden. **GEVAAR OP ONGEVALLEN.**

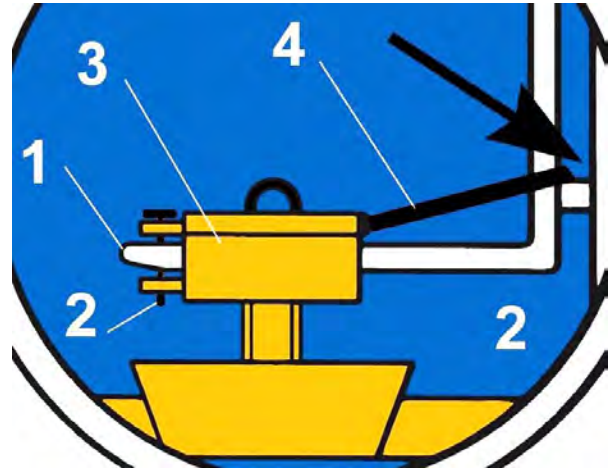
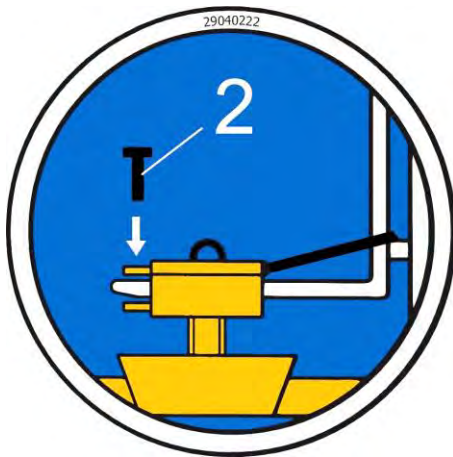

4.2 Montage van de stalen grijpklauwen WB-SQ

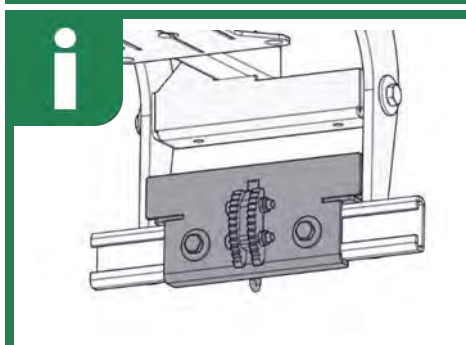
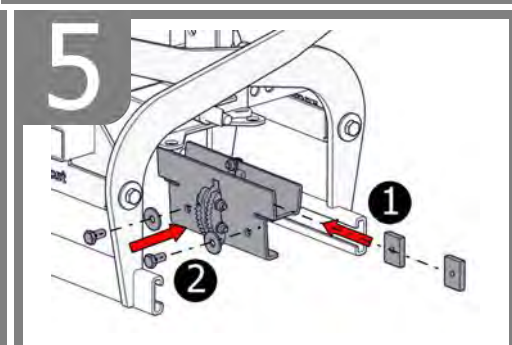
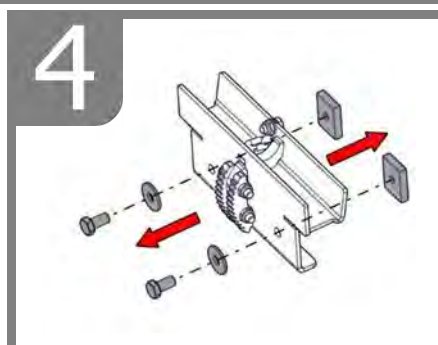
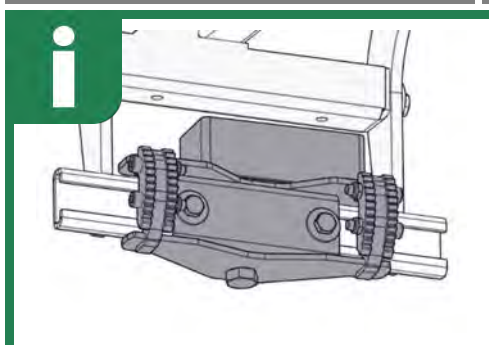
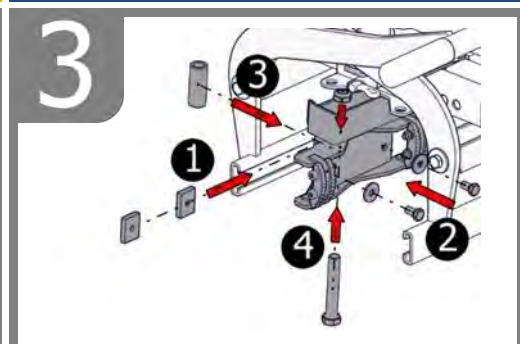
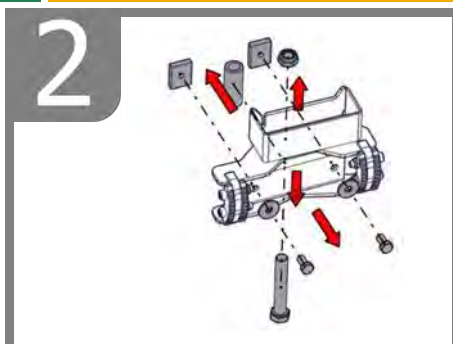
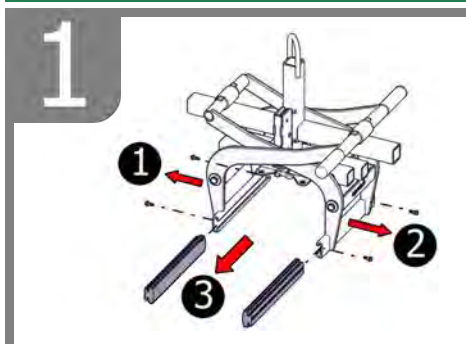
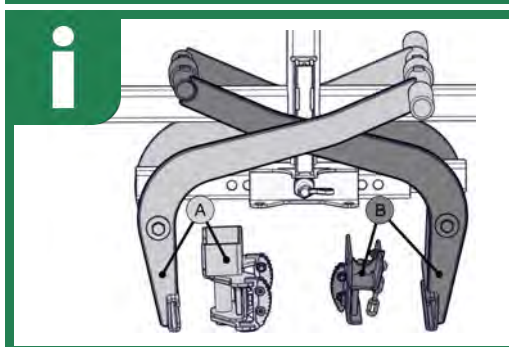
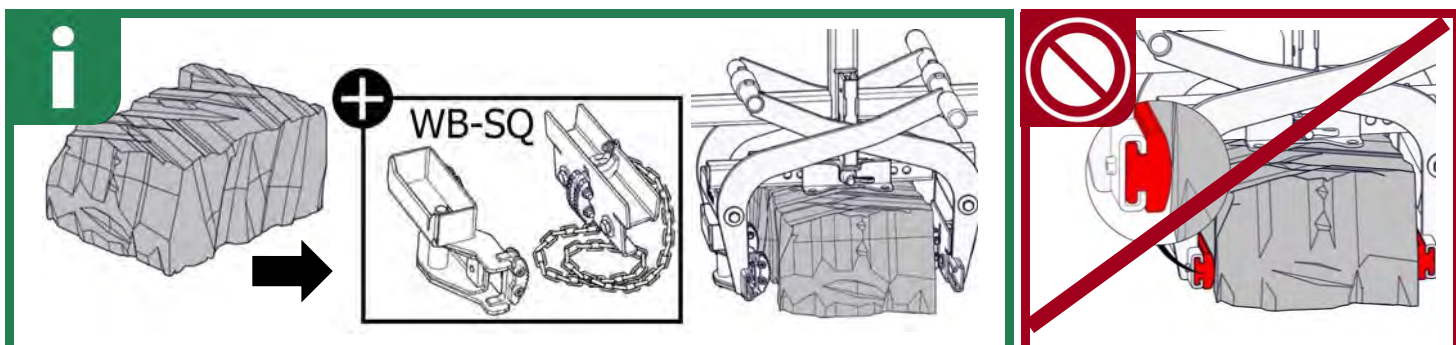

5 Afstelwerkzaamheden

5.1 Instelling van de openingsbreedte

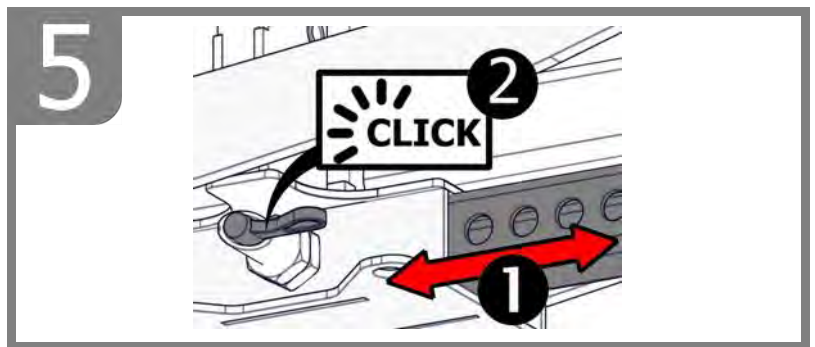
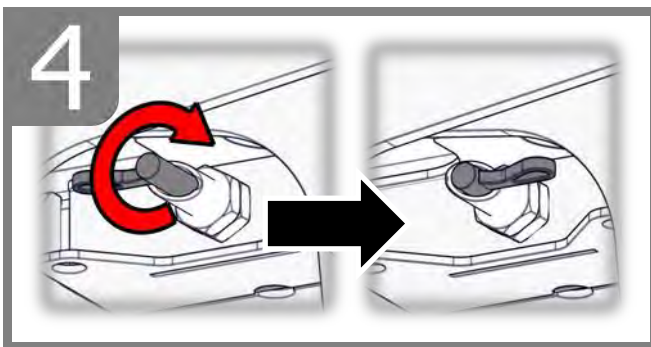
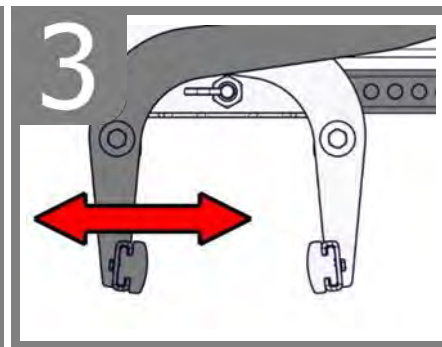
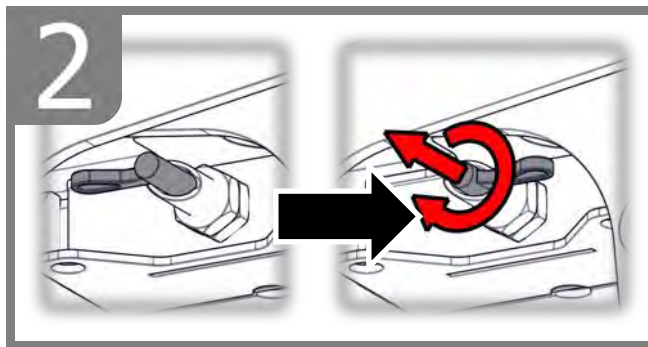
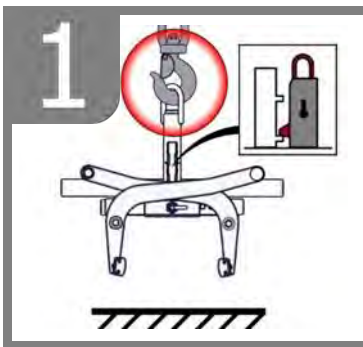
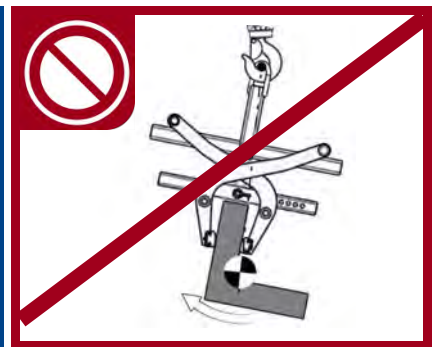
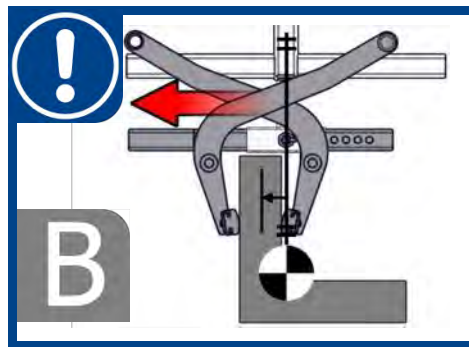
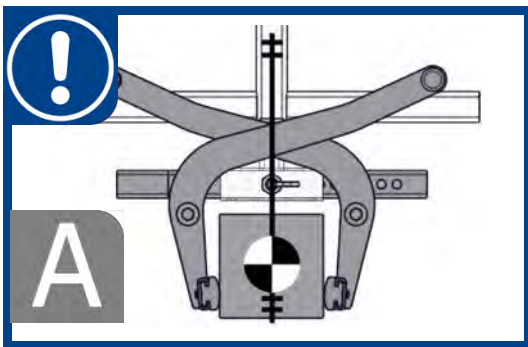
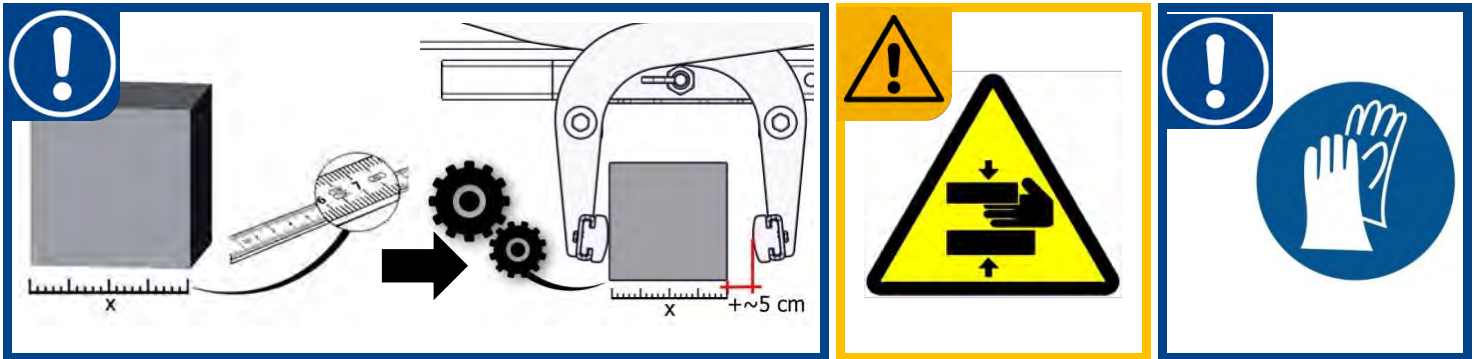

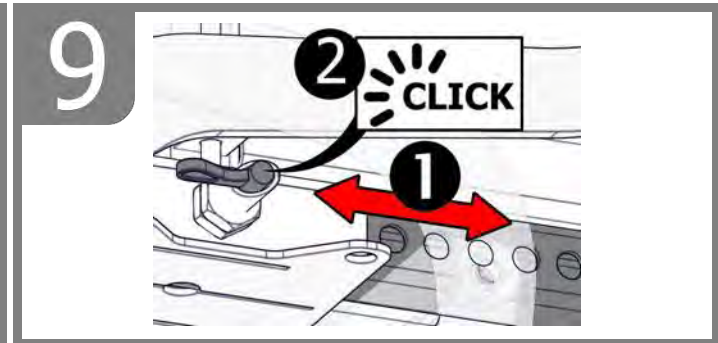
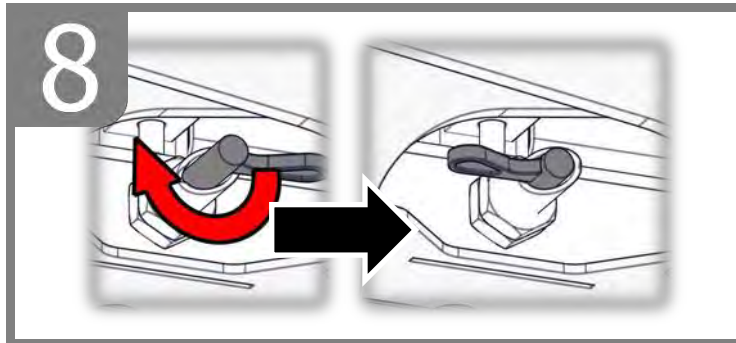
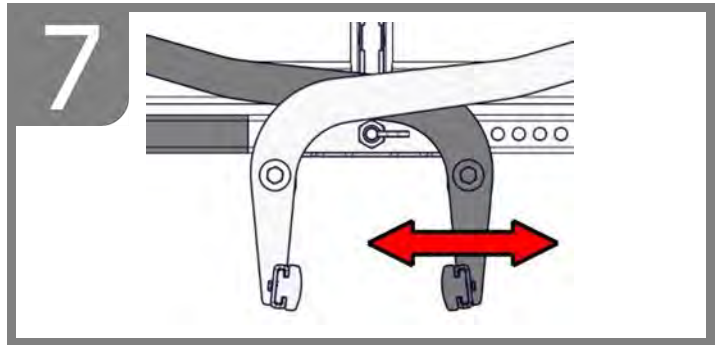
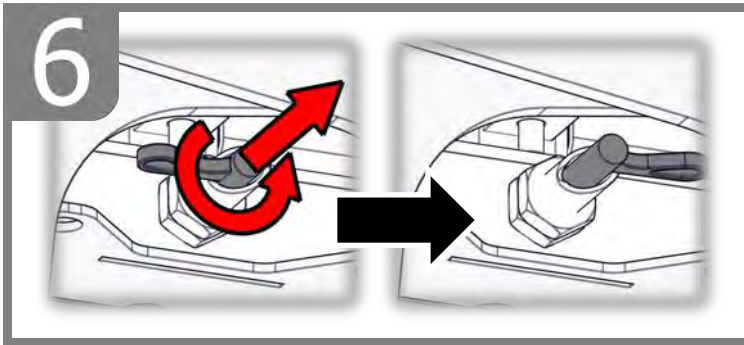

5.2 Accessoires - HVA voor seriematige werking

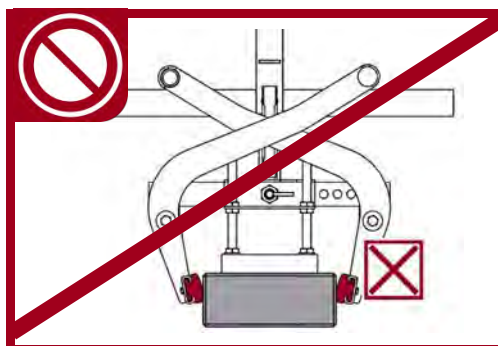
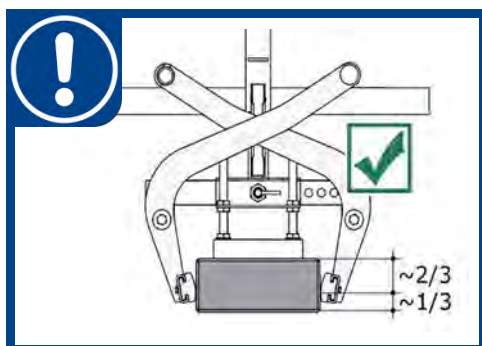
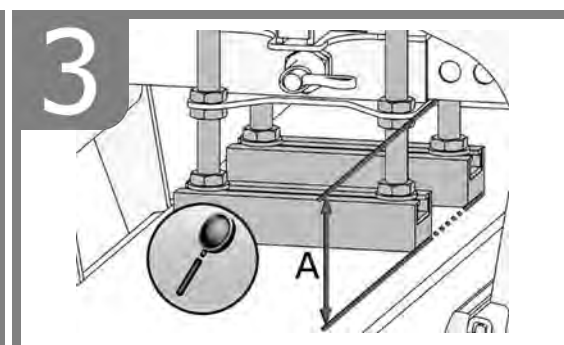
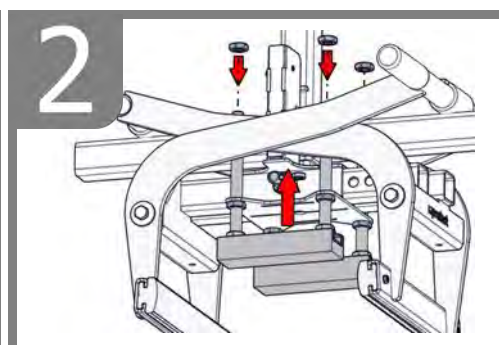
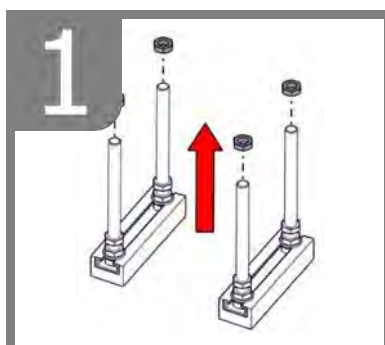
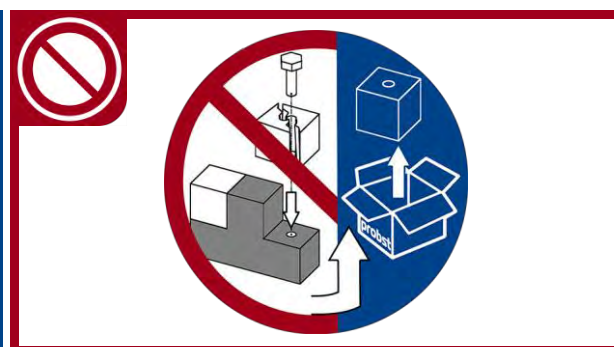
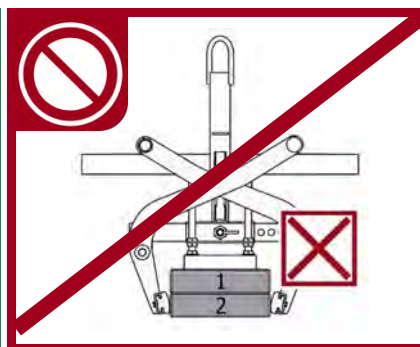
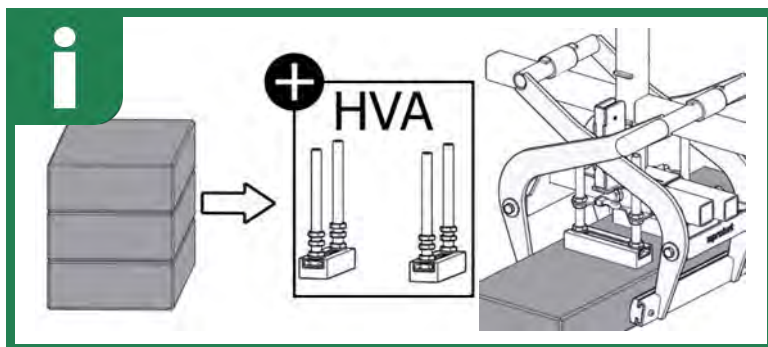

6 Bediening

6.1 Het grijpen, verplaatsen en deponeren van lasten

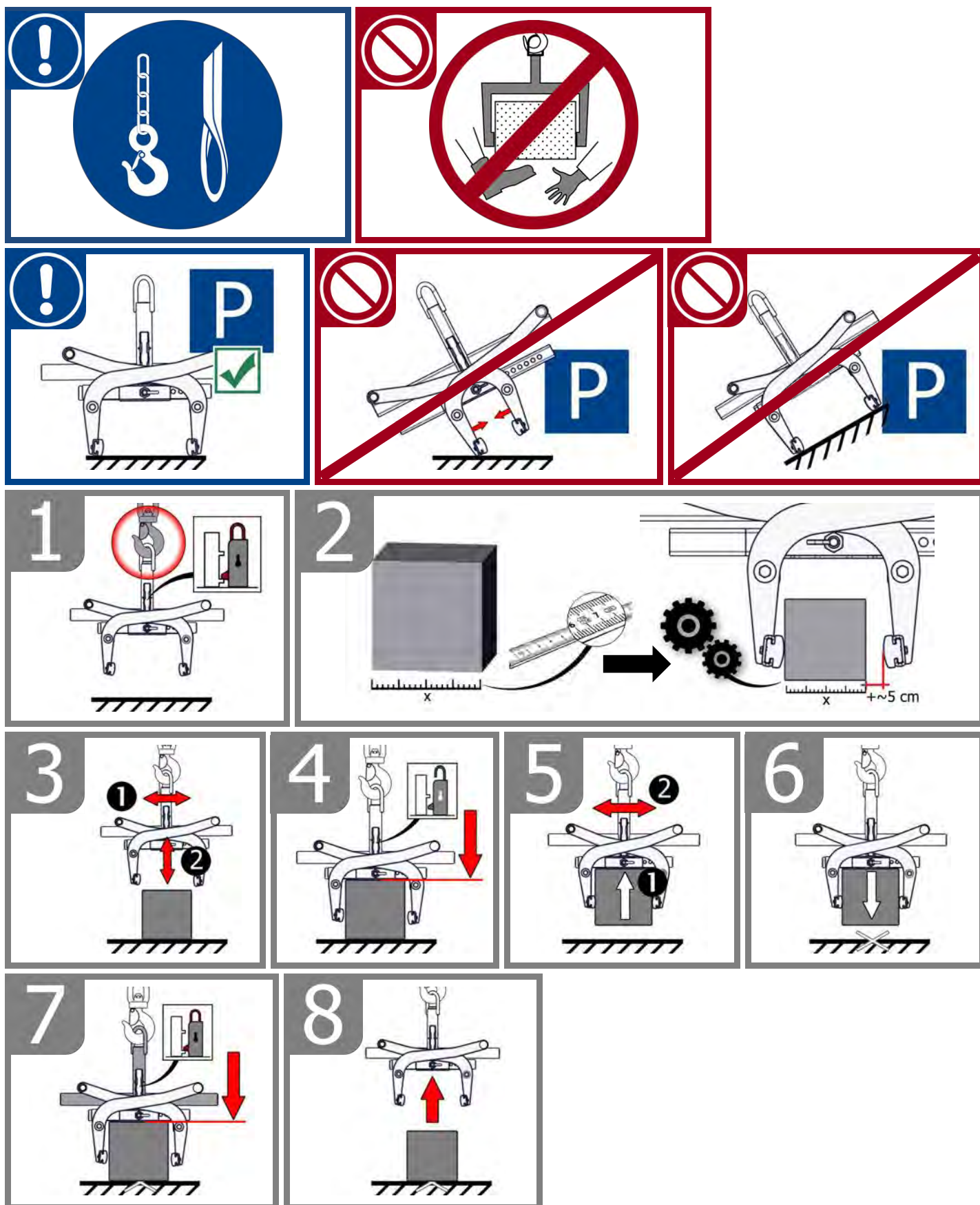

6.2 Afbeelding van de wisselautomaat

De machine is van een wisselautomaat voorzien, d.w.z. het OPENEN en SLUITEN van de grijparmen vindt plaats door het neerzetten en optillen van de machine.

Afbeeldingen van de schakelstanden van de wisselautomaat

<p>1</p> <ul style="list-style-type: none"> • Machine is door draagmachine opgetild. • Grijparmen zijn open. 	<p>2</p> <ul style="list-style-type: none"> • Machine wordt op het te grijpen materiaal neergezet. • Grijparmen zijn open. 	<p>3A</p> <ul style="list-style-type: none"> • Machine wordt door de draagmachine opgetild. • Te grijpen materiaal is gespannen en wordt naar de plaats van bestemming getransporteerd.
<p>3B</p> <ul style="list-style-type: none"> • Bij foutieve schakeling moet de schakelaar handmatig (bijv. met een schroevendraaier) weer terug worden gedrukt. 1) 	<p>4</p> <ul style="list-style-type: none"> • Machine is met te grijpen materiaal neergezet. • Grijparmen zijn open. 	<p>5/1</p> <ul style="list-style-type: none"> • Machine is door draagmachine opgetild. • Grijparmen zijn open. (Afstelpositie van het toestel op de grond).



1) Anders kan dit tot foutieve schakelingen leiden, wat resulteert in vervorming of defect raken van de wisselautomaat bij het neerzetten van de last.

Het schokkend optillen of neerlaten van het apparaat, maar ook het snel rijden met het draagapparaat/hefgereedschap over oneffen terrein is verboden!



Bij het vervangen van een defecte wisselautomaat dient men erop te letten, dat de gleuven van de beide spanstiften **altijd** omlaag wijzen.

De positie van de gleuven mag **nooit** boven of in het midden zitten, omdat anders het gevaar bestaat dat de wisselautomaat bij het omschakelen klem kan gaan zitten!

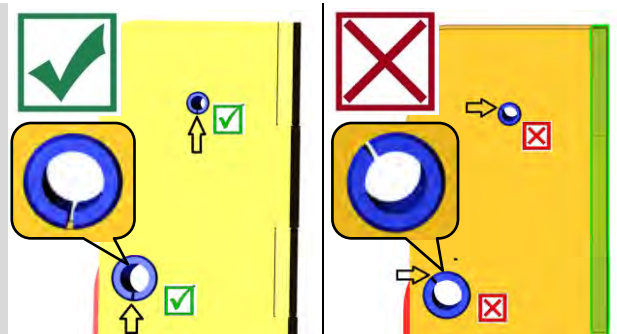

6.3 Bediening: Stalen grijpklaauwen WB-SQ

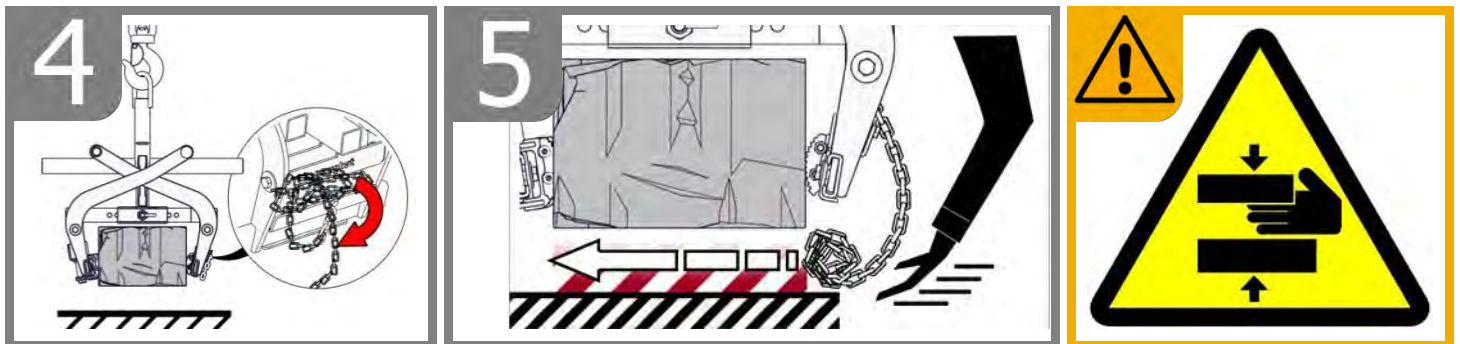
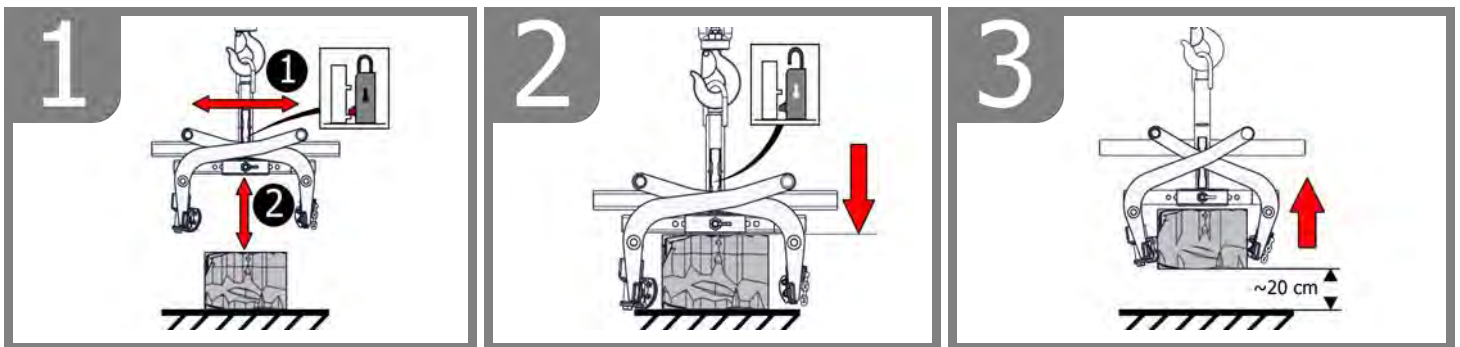
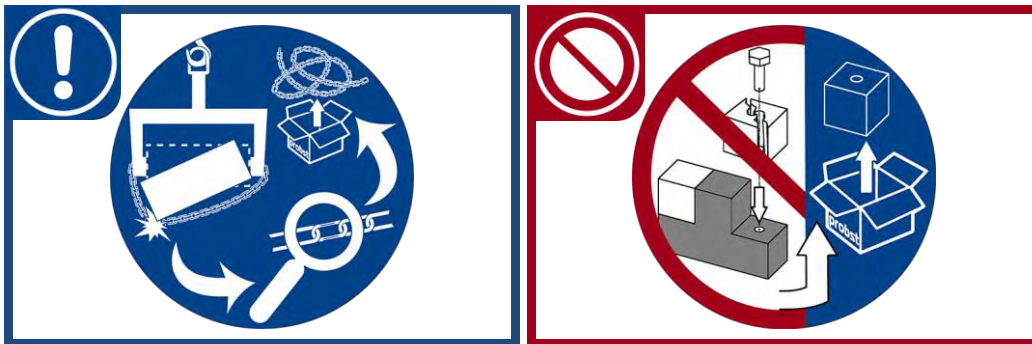
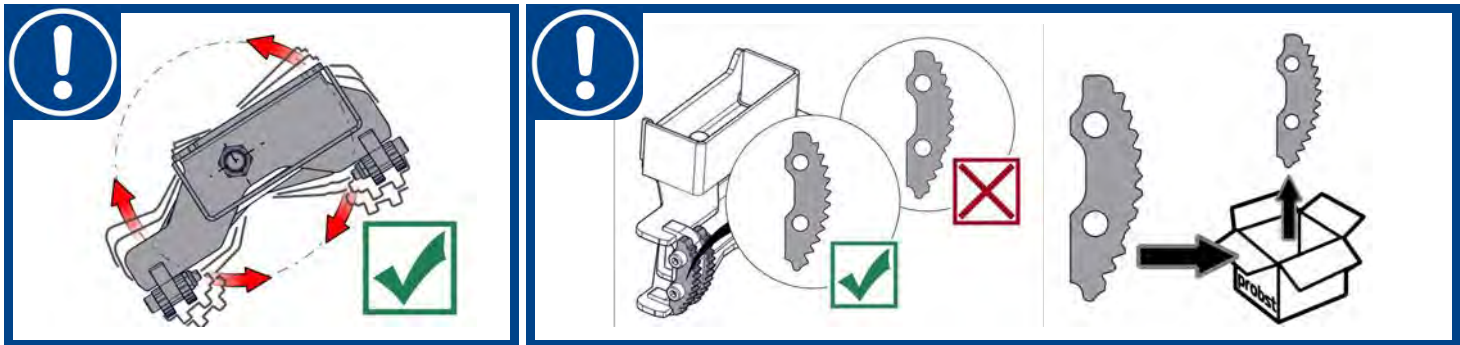

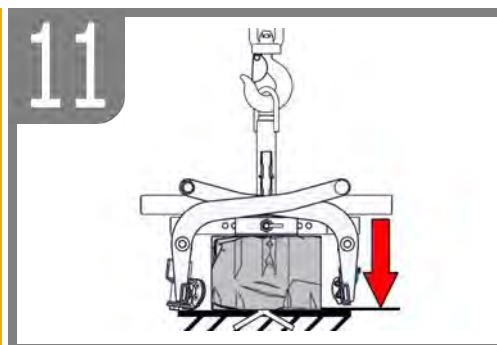
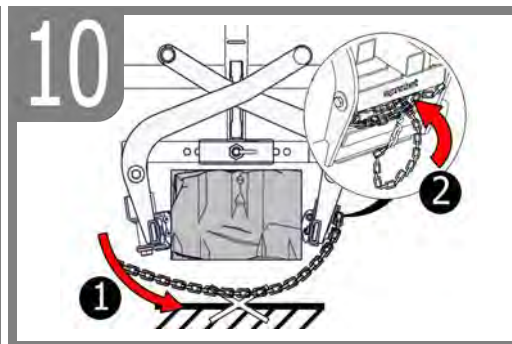
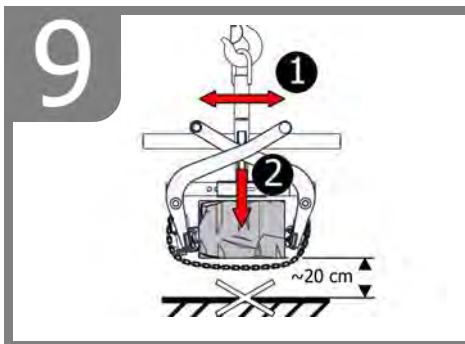
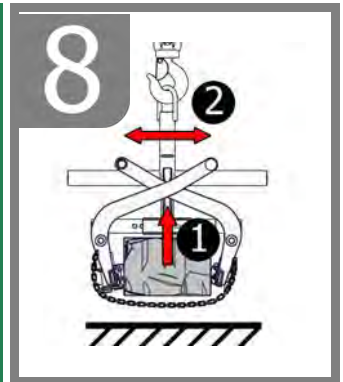
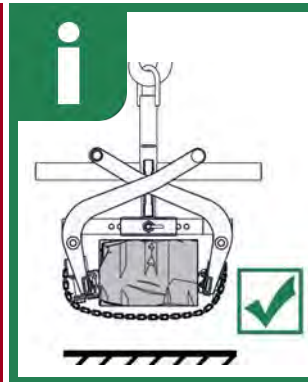
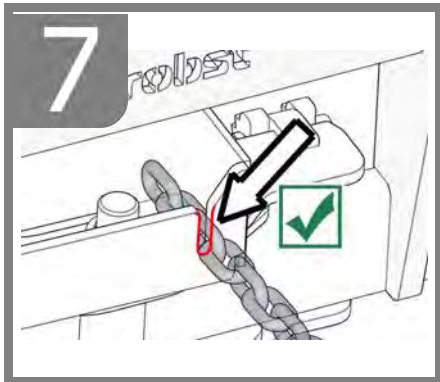

7 Onderhoud en verzorging

7.1 Onderhoud



Om onberispelijke functie, bedrijfsveiligheid en levensduur van het toestel te garanderen, moeten de in de tabel opgesomde onderhoudswerkzaamheden volgens de aangegeven perioden worden uitgevoerd

Er mogen **enkel originele vervangonderdelen** gebruikt worden om de garantie te kunnen behouden.



Hierbij moet erop worden gelet, dat alle werkzaamheden uitsluitend buiten bedrijf mogen plaatsvinden!

Om verwondingen te vermijden, moet er bij alle werkzaamheden gecontroleerd worden of het toestel zichzelf niet per ongeluk sluiten kan.

7.1.1 Mechanica

ONDERHOUDSPERIODE	Uit te voeren werkzaamheden
Eerste inspectie na 25 bedrijfsuren	<ul style="list-style-type: none"> Controleer of draai alle bevestigingsschroeven vast (mag alleen door een gekwalificeerd persoon worden uitgevoerd).
Elke 50 bedrijfsuren	<ul style="list-style-type: none"> Draai alle bevestigingsschroeven opnieuw aan (zorg ervoor dat de schroeven worden aangedraaid volgens de geldige aanhaalmomenten van de betreffende sterkteklassen). Controleer alle bestaande veiligheidselementen (zoals vouwpennen) op een goede werking en vervang defecte veiligheidselementen. → 1) Controleer alle verbindingen, geleiders, pennen en tandwielen, kettingen op goede werking, stel ze bij of vervang ze indien nodig. Controleer de grijpbekken (indien aanwezig) op slijtage en reinig ze, vervang ze indien nodig. Alle bestaande geleidingen en verbindingen van bewegende delen of machineonderdelen moeten worden gesmeerd / gesmeerd om slijtage te verminderen en voor een optimale bewegingsvolgorde. Smeer alle smeernippels (indien aanwezig) met een vetspuit. Smeer alle bestaande schuifgeleiders. Aanbevolen smeermiddel Mobilgrease HXP 462)
Minstens 1x per jaar (verkort de inspectie-interval in geval van zware bedrijfsomstandigheden)	<ul style="list-style-type: none"> Inspectie van alle ophangingsonderdelen, alsmede de bouten en beugels. Inspectie op scheuren, slijtage, corrosie en functionele veiligheid door een deskundige.

1)

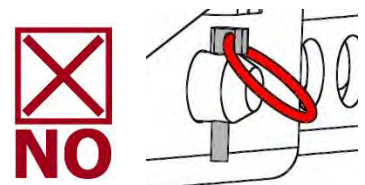
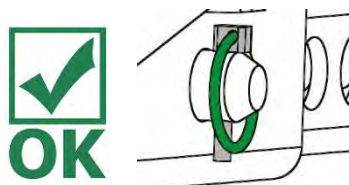

Gummi-grijparmen



Regelmatig controleren op vuil (bv. kleine steentjes) in het bovenste deel van rubberen grijparmen (6)(zie rode punten in "X" in afb. 2) → zie afb. 1 / afb. 2.

Probleem: Vuil kan de rubberen grijparmen (6) tijdens het grijpen beschadigen (kleine steentjes kunnen in het rubber drukken).

Oplossing: Vuil op de grijparmen (6) weghalen. Bij grotere vuildeeltjes is het gewenst de grijparmen te demonteren en te reinigen.

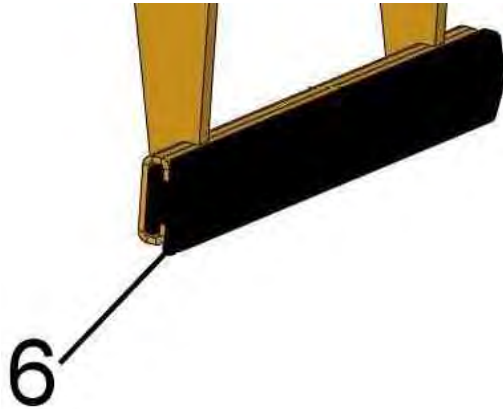

Afb. 1

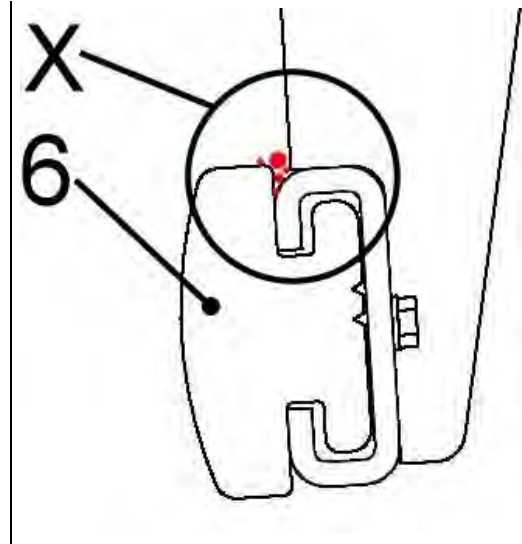

Afb. 2

7.1.2 Meer informatie over de stalen grijpvlak (WB-SQ)

Voor elk gebruik:	<ul style="list-style-type: none"> Het stalen grijpvlak controleren op beweeglijkheid, slijtage en vervuiling. Afsletten (stompe) of gebogen stalen grijpvlakken moeten vervangen worden!
Regelmatig:	<ul style="list-style-type: none"> Reiniging van het toestel met hogedrukreiniger (warm water).
Wekelijks:	<ul style="list-style-type: none"> Beweeglijke onderdelen smeren en inoliën.

WEISSELAUTOMAAAT



De wisselautomaat mag **nooit** met vet of olie gesmeerd worden!
Zichtbaar vuil met hogedrukreiniger reinigen!

7.2 Verhelpen van storingen

STORING	OORZAAK	OPLOSSING
De klemkracht is niet voldoende, de last glijdt weg.		
	<ul style="list-style-type: none"> De grijpklauwen zijn versleten 	<ul style="list-style-type: none"> Grijpklauwen vernieuwen
	<ul style="list-style-type: none"> Draaglast is groter dan toegestaan 	<ul style="list-style-type: none"> Draaglast verminderen
(Grijpbereik-instelling) (optional)	<ul style="list-style-type: none"> De verkeerde grijpbereik is ingesteld 	<ul style="list-style-type: none"> Grijpbereik volgens de te transporteren goederen instellen.
(Materiaaleigenschappen)	<ul style="list-style-type: none"> Het materiaaloppervlak is vervuild of het bouw materiaal is niet voor dit apparaat geschikt / toegestaan. 	<ul style="list-style-type: none"> Materiaaloppervlak controleren of overleggen met fabrikant of bouw materiaal voor dit apparaat is toegestaan.
Het apparaat hangt scheef		
	<ul style="list-style-type: none"> De grijper is eenzijdig belast 	<ul style="list-style-type: none"> Last symmetrisch verdelen
(Grijpbereik-instelling) (optional)	<ul style="list-style-type: none"> De grijpbereik is niet symmetrisch ingesteld 	<ul style="list-style-type: none"> Instelling van de grijpbereik controleren en corrigeren
Wisselautomaat functioneert niet (optional)		
(Mechanica)	<ul style="list-style-type: none"> Wisselautomaat functioneert niet 	<ul style="list-style-type: none"> Wisselautomaat met stoomstraler reinigen Corrigeer de foutieve schakeling (→ zie hoofdstuk "Afbeelding van de wisselautomaat"). Gebruik van de wisselautomaat vervangen

7.3 Reparaties



- Reparaties aan het toestel mogen uitsluitend door personen worden uitgevoerd die daarvoor de noodzakelijke kennis en competentie bezitten.
- Voordat opnieuw in gebruik wordt genomen, **moet** een buitengewone controle door een gekwalificeerd persoon of deskundige worden uitgevoerd.

7.4 Controleplicht



- De ondernemer dient ervoor te zorgen dat het apparaat ten minste eens per jaar door een deskundige wordt gekeurd en dat vastgestelde manco's worden verholpen (→ DGUV richtlijn 100-500).
- De desbetreffende wettelijke bepalingen en de bepalingen van de conformiteitsverklaring dienen in acht te worden genomen!
- De keuring door een deskundige kan ook door de fabrikant Probst GmbH worden gedaan. Neem contact met ons op via: service@probst-handling.de
- Wij adviseren om het vignet van de technische keuringsdienst „Sachkundigenprüfung / Expert inspection“ (VEILIGHEIDSKEURING) goed zichtbaar aan te brengen nadat de keuring is uitgevoerd en manco's zijn verholpen (Bestelnr.: 2904.0056+Tüv-sticker met jaartal).



De keuring door de deskundig moet absoluut worden gedocumenteerd!

Apparaat	Jaar	Datum	Deskundige	Bedrijf

7.5 Instructie m.b.t. het typeplaatje



- Het apparaattype, apparaatnummer en bouwjaar zijn belangrijke opgaven voor de identificatie van het apparaat. Zij dienen bij bestellingen van onderdelen, aanspraken op fabrieksgarantie en overige aanvragen m.b.t. het apparaat altijd mee worden aangegeven.
- Het maximale draagvermogen (WLL) geeft aan voor welke maximale belasting het apparaat ontworpen is. Het maximale draagvermogen (WLL) mag **niet** worden overschreden.
- Bij het gebruik bij het hefgereedschap/draagapparaat (bv. kraan, kettingtakel, vormheftruck, bagger) moet ook rekening worden gehouden met het op het typeplaatje aangeduide eigen gewicht.



Voorbeeld:

7.6 Instructie m.b.t. verhuur/uitlenen van PROBST apparaten



Bij iedere uitlening/verhuur van PROBST apparaten **moet** absoluut de daarbij horende **originele handleiding** worden meegeleverd (indien de taal van het land van de betreffende gebruiker afwijkt, dient bovendien de desbetreffende vertaling van de originele handleiding te worden meegeleverd)!

8 Verwijdering / recycling van apparatuur en machines



Het product **mag alleen** door gekwalificeerd personeel buiten gebruik worden gesteld en worden voorbereid voor verwijdering / recycling. Dienovereenkomstig aanwezige **afzonderlijke componenten** (zoals metalen, kunststoffen, vloeistoffen, batterijen/accu's enz.) moeten worden verwijderd/gerecycled in overeenstemming met de **nationaal/landspecifiek geldende wetten en verordeningen inzake afvalverwerking!**



Het product mag niet met het huisvuil worden meegegeven!

De garantie voor dit apparaat wordt enkel toegekend wanneer de voorgeschreven onderhoudswerken (door een geautoriseerde werkplaats) uitgevoerd werden. Na iedere onderhoudsbeurt moet het onderhoudsblad (met handtekening en stempel) onmiddellijk aan ons doorgestuurd worden. ¹⁾

¹⁾ per e-mail aan: service@probst-handling.de / per fax of post

Gebruiker: _____
 Apparaattype: _____ Artikel-Nr.: _____
 Apparaat -Nr.: _____ Bouwjaar: _____

Garantiewaarborg na 25 bedrijfsuren		
Datum:	Onderhoudstype:	Onderhoud door firma:
		<i>Stempel</i>
	
		Naam / Handtekening

Garantiewaarborg na 50 bedrijfsuren		
Datum:	Onderhoudstype:	Onderhoud door firma:
		<i>Stempel</i>
	
		Naam / Handtekening
		Onderhoud door firma:
		<i>Stempel</i>
	
		Naam / Handtekening
		Onderhoud door firma:
		<i>Stempel</i>
	
		Naam / Handtekening

Garantiewaarborg 1x per jaar		
Datum:	Onderhoudstype:	Onderhoud door firma:
		<i>Stempel</i>
	
		Naam / Handtekening
		Onderhoud door firma:
		<i>Stempel</i>
	
		Naam / Handtekening

TSZ-UNI



IT | Istruzioni d'uso

Indice

1	Certificato di conformità norme CE	3
2	Sicurezza	4
2.1	Istruzioni di sicurezza	4
2.2	Definizioni dei termini	4
2.3	Definizione di personale qualificato / esperto	4
2.3.1	Spiegazione dei pittogrammi	5
2.4	Segni di sicurezza	6
2.5	Misure di sicurezza personali	7
2.6	Equipaggiamento antinfortunistico	7
2.7	Protezione contro gli infortuni	7
2.8	Controllo funzionale e visivo	7
2.8.1	Generale	7
2.9	Sicurezza durante l'esercizio	8
2.9.1	Informazioni generali	8
2.9.2	Supportare unità / paranco	8
3	Aspetti generali	9
3.1	Uso autorizzato	9
3.2	Panoramica e struttura	11
3.3	Accessori	11
3.4	Dati tecnici	11
4	Montaggio	12
4.1	Connessione meccanica	12
4.1.1	Occhiello di sospensione/bulloni di sospensione	12
4.1.2	Gancio di carico e imbracatura	12
4.1.3	Rotori (optional)	12
4.1.4	Tasca portaforca (optional)	13
4.2	Installazione degli artigli di presa in acciaio WB-SQ	14
5	Regolazioni	15
5.1	Regolazione dell'ampiezza di presa (opzionale)	15
5.2	Accessori - HVA per la modalità batch	17
6	Funzionamento	18
6.1	Afferrare, spostare e depositare i carichi	18
6.2	Figura del dispositivo di rilascio automatico	19
6.3	Funzionamento: Unghie di presa in acciaio WB-SQ	20
7	Cura e manutenzione	22
7.1	Manutenzione	22
7.1.1	Meccanica	22
7.1.2	Addizionali per ganasce con denti in acciaio (WB-SQ)	23
7.2	Risoluzione dei problemi	24
7.3	Riparazioni	24
7.4	Procedure di sicurezza	25
7.5	Indicazioni per l'etichetta identificativa	26
7.6	Indicazioni per il noleggio/leasing di attrezzature PROBST	26
8	Smaltimento / riciclaggio di apparecchi e macchinari	26

Ci riserviamo il diritto di apportare modifiche alle informazioni e alle illustrazioni delle istruzioni per l'uso.

1 Certificato di conformità norme CE

Descrizione: Pinza universale per manufatti TSZ
Modello: TSZ-UNI
Articolo n.: 53100338



Produttore: Probst GmbH
Gottlieb-Daimler-Straße 6
71729 Erdmannhausen, Germany
info@probst-handling.de
www.probst-handling.com

La macchina sopra descritta rispetta I requisiti principali delle seguenti normative della EU:

2006/42/CE (linea di guida CE)

I seguenti standard e specifiche tecniche sono utilizzati in estratti:

DIN EN ISO 12100

Sicurezza del macchinario - Principi generali di progettazione - Valutazione del rischio e riduzione del rischio

DIN EN ISO 13857:2008

Sicurezza della macchina — Distanza di sicurezza al fine di evitare pericolo di passaggio sotto e basso carichi sospesi.

Persona autorizzata per CE-documentazione:

Nome: Jean Holderied

Indirizzo: Probst GmbH; Gottlieb-Daimler-Straße 6; 71729 Erdmannhausen, Germany

Firma, dati del sottoscrittore:

Erdmannhausen, 02.08.2023.....
(Eric Wilhelm, Direttore generale)

2 Sicurezza

2.1 Istruzioni di sicurezza



Pericolo per la vita!

Indica un pericolo. Se non viene evitato, il risultato è la morte e le lesioni gravi.



Situazione pericolosa!

Indica una situazione di pericolo. Se non viene evitato, possono verificarsi lesioni o danni alle cose.



Proibizione!

Denota un divieto. Se non viene osservato, il risultato è la morte e gravi lesioni o danni materiali.



Informazioni importanti o consigli utili per l'uso.

2.2 Definizioni dei termini

Afferra campo:	<ul style="list-style-type: none"> indica le dimensioni minime e massime del prodotto da afferrare con questo dispositivo.
Afferra merce (afferra merce):	<ul style="list-style-type: none"> è il prodotto che viene afferrato o trasportato.
Larghezza di apertura:	<ul style="list-style-type: none"> è composto dal campo di presa e dalla dimensione di ingresso. <i>campo di presa + dimensione d'ingresso = campo di apertura</i>
Profondità di immersione:	<ul style="list-style-type: none"> corrisponde all'altezza massima di presa dei prodotti di presa, a causa dell'altezza dei bracci di presa dell'apparecchio.
Dispositivo:	<ul style="list-style-type: none"> è la denominazione del dispositivo di presa.
Dimensione del prodotto:	<ul style="list-style-type: none"> sono le dimensioni della merce da afferrare (ad es. lunghezza, larghezza, altezza di un prodotto).
Un peso morto:	<ul style="list-style-type: none"> è il peso a vuoto (senza materiale di presa) dell'apparecchio.
Capacità di carico (WLL *):	<ul style="list-style-type: none"> indica il carico massimo ammissibile dell'apparecchio (per il sollevamento di merci afferrate). <p>*= WLL → (Inglese:) Working Load Limit</p>
Zona vicina al terreno:	<ul style="list-style-type: none"> il carico deve essere abbassato appena sopra il suolo (circa 0,5 m) subito dopo essere stato prelevato (ad esempio da un pallet o da un camion). Per il trasporto, sollevare il carico solo all'altezza necessaria (raccomandazione: circa 0,5 m da terra).

2.3 Definizione di personale qualificato / esperto

I lavori di installazione, manutenzione e riparazione di questo apparecchio devono essere eseguiti solo da personale qualificato o da esperti!

Personale qualificato o esperti devono avere le necessarie conoscenze professionali nei seguenti settori, per quanto applicabili a questo apparecchio:

- per la meccanica
- per l'idraulica
- per la pneumatica
- per l'impianto elettrico

2.3.1 Spiegazione dei pittogrammi

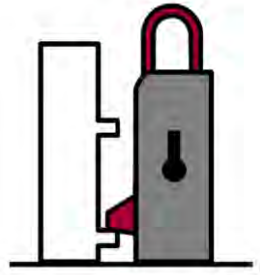

Rilascio automatico chiuso

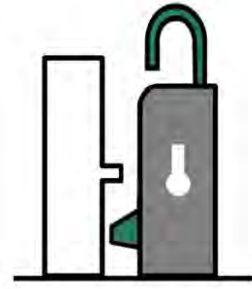

Rilascio automatico aperto

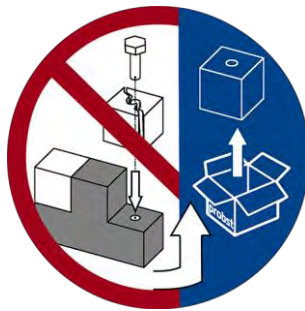

Non utilizzare accessori danneggiati, se necessario sostituirli!



Non tenere gli arti sotto il carico sollevato!
Rischio di lesioni!



Imbracature consentite: ganci e imbracature di sollevamento.



La catena di sicurezza del carico (catena di ancoraggio) non deve essere utilizzata come catena di imbracatura! La catena di fissaggio del carico potrebbe rompersi e il carico cadere!

Pericolo di lesioni e morte!





Se il carico cade nella catena di fissaggio del carico, la catena deve essere ispezionata professionalmente e, se necessario, sostituita.

Non continuare a utilizzare una catena di sicurezza danneggiata!

2.4 Segni di sicurezza



SEGNI DI DIVIETO

Simbolo	Significato	Articolo-N.	Misura
	Non calpestare mai un carico sospeso. Pericolo per la vita!	29040210 29040209 29040204	Ø 30 mm Ø 50 mm Ø 80 mm
	Non è consentito il trasporto di elementi non rettangolari!	29040213 29040212 29040211	Ø30 mm Ø50 mm Ø80 mm
	Non sollevare gli elementi al di fuori del loro baricentro (sempre nel centro di gravità).	29040216 29040215 29040214	Ø30 mm Ø50 mm Ø80 mm

SEGNI DI AVVERTIMENTO

Simbolo	Significato	Articolo-N.:	Misura:
	Pericolo che le mani restino schiacciate	29040221 29040220 29040107	30 x 30 mm 50 x 50 mm 80 x 80 mm

SEGNI OBBLIGATORI

Simbolo	Significato	Articolo-N.	Misura
	Ogni persona coinvolta nelle operazioni di installazione, avviamento, utilizzo, manutenzione e riparazione del dispositivo deve aver letto e compreso le istruzioni d'uso e, in particolare, il capitolo "Sicurezza" qui contenuto.	29040665 29040666 29041049	Ø30 mm Ø50 mm Ø 80 mm
	L'utilizzo manuale è consentito solamente con macchine dotate di appositi manubri rosso.	29040227 29040226 29040225	Ø 30 mm Ø 50 mm Ø 80 mm

OPZIONALE

	Assicurarsi che le forze siano meccanicamente fissate (con perno di bloccaggio e catena o fune di sicurezza) al mezzo di sollevamento.	29040223 29040222	Ø 50 mm Ø 80 mm
---	--	----------------------	--------------------

2.5 Misure di sicurezza personali



- Tutti gli operatori devono aver letto e compreso le istruzioni d'uso.
- Solo apersonale qualificato ed autorizzato è concesso l'utilizzo del dispositivo e delle component collegate (dispositivo di sollevamento).



- La **guida manual** è consentita **solo** su dispositivi **con maniglie**.
Altrimenti c'è il rischio di lesioni alle mani!

2.6 Equipaggiamento antinfortunistico

In conformità con i requisiti tecnici relativi alla sicurezza, l'equipaggiamento protettivo è costituito da:

- Indumenti antinfortunistici
- Guanti antinfortunistici
- Scarpe antinfortunistiche

2.7 Protezione contro gli infortuni



- Mettere in sicurezza l'area di lavoro per le persone non autorizzate, soprattutto i bambini, su una vasta area.
- **Attenzione durante i temporali - pericolo di fulmini!**
A seconda dell'intensità del temporale, interrompere il lavoro con l'attrezzatura se necessario.



- Illuminate sufficientemente l'area di lavoro.
- **Attenzione ai materiali da costruzione bagnati, congelati, ghiacciati e sporchi!**
C'è il pericolo che il materiale di presa scivoli via. → PERICOLO DI INCIDENTE!

2.8 Controllo funzionale e visivo

2.8.1 Generale



- Prima di di ogni operazione l'apparecchio deve essere sempre sottoposto ad un controllo funzionale e delle condizioni.
- Gli interventi di manutenzione, di lubrificazione e l'eliminazione delle anomalie devono essere sempre eseguiti a macchina spenta!



- In caso di anomalie che possono pregiudicare la sicurezza, l'apparecchio può essere riutilizzato soltanto dopo l'integrale eliminazione dell'anomalia.
- In caso di crepe, spaccature o parti danneggiate in qualsiasi componente, interrompere immediatamente l'utilizzo.



- Le istruzioni d'uso dell'apparecchio devono essere sempre accessibili in corrispondenza del luogo d'impiego.
- La targhetta identificativa applicata all'apparecchio non deve essere rimossa.
- Simboli non riconoscibili (come regolamenti o divieti) devono essere sostituiti.

2.9 Sicurezza durante l'esercizio

2.9.1 Informazioni generali



- I lavori con l'apparecchio possono essere eseguiti solo in prossimità del suolo. È vietato far oscillare l'unità sulle persone.
- È vietato sostare sotto un carico sospeso. **Pericolo per la vita!**



- La guida manuale è consentita solo per gli apparecchi con maniglie.



- È vietato alle persone di rimanere nell'area di lavoro durante il funzionamento! A meno che non sia indispensabile, a causa della natura dell'applicazione dell'apparecchio, ad esempio guidando manualmente l'apparecchio (tramite maniglie).
- È vietato sollevare o abbassare a scatti l'attrezzo con o senza carico, così come guidare velocemente con il portapacchi/sollevatore **su terreni irregolari!** In generale, con il carico sollevato, guidare con il trasportatore/sollevatore (ad esempio l'escavatore) solo a **velocità di marcia** - evitare vibrazioni inutili. **Pericolo:** il carico potrebbe cadere o l'attrezzatura di movimentazione del carico potrebbe essere danneggiata!



- Non prelevare mai la merce in modo eccentrico (sempre al centro di gravità del carico), altrimenti si corre il rischio di ribaltare la merce.
- Il dispositivo non deve essere aperto se il percorso di apertura è bloccato da una resistenza.



- La capacità di carico e i diametri nominali dell'apparecchio non devono essere superati.
- L'operatore non deve lasciare la stazione di controllo finché l'unità è carica di carico e deve sempre avere il carico in vista.



- Non strappare i carichi bloccati con l'apparecchio.
- Non tirare o trascinare mai i carichi ad angolo. In caso contrario, parti dell'apparecchio potrebbero essere danneggiate (vedi fig. A →).

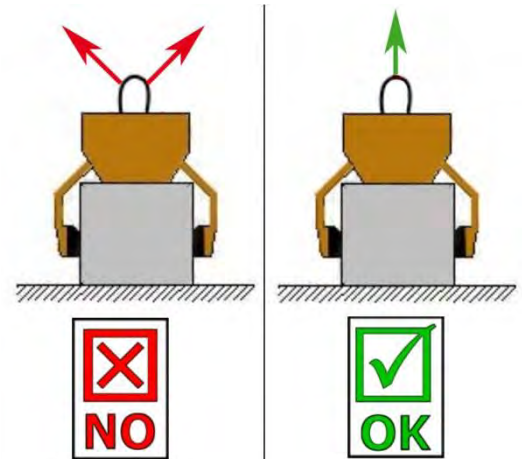

Fig. A

2.9.2 Supportare unità / paranco



- Lo stato e le condizioni dell'escavatore idraulico o di altre macchine per il sollevamento (supportare unità / paranco) devono essere tali da garantire la sicurezza sul lavoro.
- L'utilizzo della macchina per il sollevamento (supportare unità / paranco) è consentito solo da parte di personale autorizzato, certificato e qualificato.
- Lo staff operativo deve possedere tutte le qualifiche necessarie.



- **Non bisogna superare per nessun motivo la capacità di portata prevista per l'escavatore idraulico o per altre macchine per il sollevamento / e l'attrezzatura di imbracatura!**

3 Aspetti generali

3.1 Uso autorizzato

Il dispositivo (TSZ-UNI) è realizzato per la presa, trasporto e la seguente posa degli elementi presi come, gradini, cordoli, elementi angolari, elementi a L e pietre naturali (per mezzo dell'accessorio "ganasce in acciaio WB-SQ) in congiunzione con il corrispettivo dispositivo di sollevamento (es. Escavatore).



- L'apparecchio deve essere utilizzato in modo regolare ed esclusivamente per le finalità descritte nelle istruzioni d'uso rispettando le norme sulla sicurezza vigenti e le disposizioni previste dalle norme CE relativamente al certificato di conformità.
- È vietato ogni utilizzo diverso da quello previsto dalle norme!
- Occorre inoltre rispettare le norme sulla sicurezza e sulla prevenzione degli infortuni localmente vigenti.



Prima di ogni utilizzo assicurarsi che:

- L'apparecchio sia adatto all'utilizzo preposto
- le condizioni funzionale e di lavoro dell'apparecchio vengano esaminate
- che i carichi da movimentare siano adatti per questo apparecchio.

In caso di dubbi in merito alle istruzioni rivolgersi al produttore prima dell'utilizzo.



ATTENZIONE: L'utilizzo dell'apparecchio è consentito solo in prossimità del terreno (→ Capitolo "Sicurezza durante il funzionamento" e "Definizioni dei termini") !



Solamente elementi con superfici parallele e piane possono essere sollevati e movimentati
Perchè gli elementi sollevati **possono cadere**.



ATTIVITÀ PROIBITE:

Modifiche non autorizzate all'apparecchio o l'uso di altri apparecchi supplementari da voi stessi costruiti mettono in pericolo la vita e l'incolumità fisica e sono quindi severamente **vietate!**

Le capacità di carico (WLL) di questo apparecchio non devono essere superate e le larghezze/intervalli di presa nominali non devono essere superati o non devono essere rispettati.

Tutti i trasporti con l'apparecchio che non sono conformi alle norme sono **severamente vietati:**

- il trasporto di persone e animali.
- presa e trasporto di pacchi di materiali da costruzione, oggetti e materiali non descritti in queste istruzioni d'uso
- sospendere i carichi da questo apparecchio con corde, catene o simili, tranne che agli occhielli di sospensione/bulloni previsti a tale scopo.
- la presa della merce da afferrare con la pellicola da imballaggio, in quanto vi è il rischio di scivolare.
- afferrare merci con una superficie che riduce il coefficiente di attrito (ad esempio superfici sfregate, trattate, sporche, congelate, rivestite, verniciate), poiché questo riduce il coefficiente di attrito tra le ganasce della pinza e la merce afferrata - rischio di scivolamento!

Rimedio: Se le ganasce della pinza e la superficie dei prodotti nell'area delle ganasce della pinza sono sporchi in qualsiasi modo, è assolutamente necessario pulirli prima di ogni operazione di presa!

- -merce di presa che può deformarsi o rompersi a causa della forza di serraggio della pinza!
- merce di presa che mostrano danni visibili o che possono rompersi a causa del loro stesso peso.
- la presa e il trasporto di merci coniche e rotonde, in quanto vi è il rischio di scivolare. (Illustrazione a destra) →
- Strati di pietra che hanno "piedi", "pance" o "distanziatori ciechi".

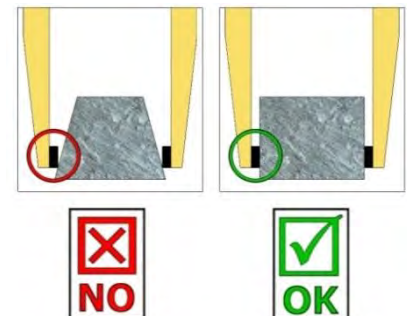

3.2 Panoramica e struttura

Fig.1

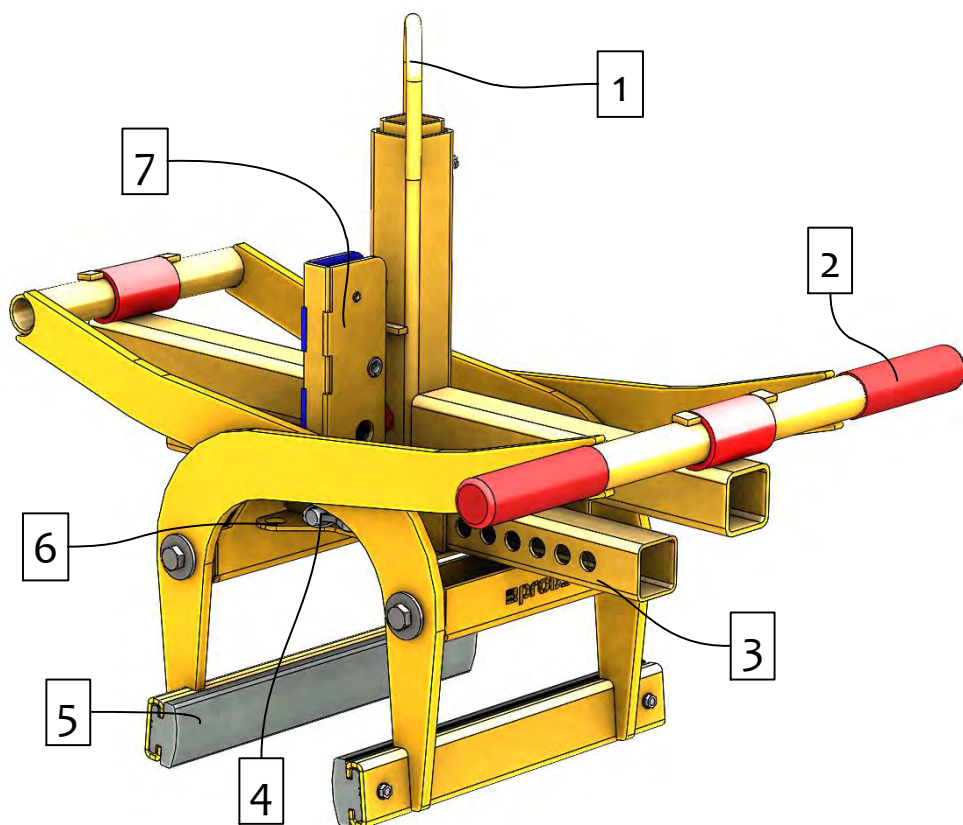

1	Occhiello di sospensione
2	Maniglia
3	Regolazione del raggio d'apertura
4	Perno per fissaggio apertura
5	Tamponi in gomma
6	Aggancio per regolatore dell'altezza (optional)
7	Rilascio automatico

3.3 Accessori



HVA-FTZ/TSZ
Posa in modalità batch

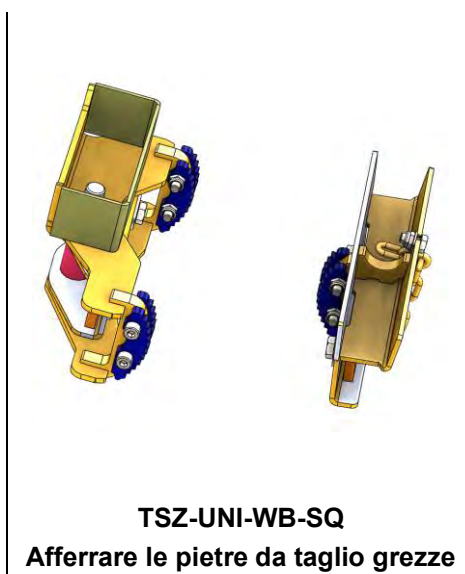

TSZ-UNI-WB-SQ
Afferrare le pietre da taglio grezze

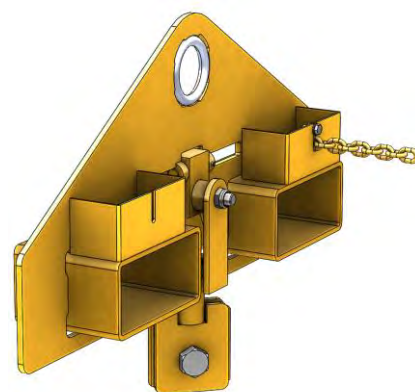

TSZ-UNI-ET
Tasca portaforca

3.4 Dati tecnici

I dati tecnici specifici (capacità di portata, peso proprio, ecc.) sono specificati nella targhetta identificativa.

4 Montaggio

4.1 Connessione meccanica

Utilizzare solamente accessori originali, in caso di dubbio contattar eil produttore.



La capacità di carico dell'apparecchio di trasporto/mezzo di sollevamento non deve essere superata dal carico dell'apparecchio, dagli accessori opzionali (motore rotante, tasca d'inserimento, braccio della gru, ecc.) e dal carico supplementare della merce di presa!

I dispositivi di presa devono sempre essere fissati in modo da poter oscillare liberamente in qualsiasi posizione.



In nessun caso le pinze devono essere collegate al paranco/carrello in modo rigido!

Può portare alla rottura della sospensione in poco tempo. Il risultato può essere la morte, lesioni estremamente gravi e danni alla proprietà!



Quando si usa l'attrezzo su accessori opzionali (come la tasca di inserimento, il braccio della gru, ecc.), non si può escludere, a causa della costruzione più bassa possibile dell'intero attrezzo (per evitare la perdita di altezza di sollevamento), che l'attrezzo possa collidere con i componenti adiacenti se l'attrezzo è sospeso in modo oscillante e posizionato sfavorevolmente quando il supporto è in movimento. Questo dovrebbe essere evitato per quanto possibile posizionando l'attrezzo in modo appropriato e guidando in modo adeguato. I danni che ne derivano non saranno regolati nell'ambito della garanzia.

4.1.1 Occhiello di sospensione/bulloni di sospensione

- L'apparecchio è dotato di occhiello di sospensione/bulloni di sospensione e può essere montato su vari supporti.



- Fate attenzione che l'occhiello di sospensione sia saldamente attaccata all'occhiello della gru/brache (gancio della gru, scivolo, ecc.) in modo che non possa scivolare.

4.1.2 Gancio di carico e imbracatura



- Il dispositivo viene fissato al supporto/sollevatore con un gancio di carico o un'imbracatura adatta. **Assicurarsi che le single catene non siano attorcigliate e non annodate e che possano scorrere liberamente.**
- L'attacco dell'apparecchio alla macchina per il sollevamento deve essere conforme alle norme di sicurezza locali.

4.1.3 Rotori (optional)



Quando si usa un rotore, una valvola di strozzamento a ruota libera deve essere installata in modo che si prevengano accelerazioni e frenate brusche che possono danneggiare il dispositivo in breve tempo.

4.1.4 Tasca portaforca (optional)



Per stabilire un collegamento sicuro tra il carrello elevatore e la tasca di inserimento (3), i denti del carrello elevatore (1) vengono inseriti nella tasca di inserimento (3).

Il bloccaggio avviene tramite viti di bloccaggio (2), inserite attraverso un foro nei denti del carrello elevatore (1), oppure tramite una catena o una corda (4), che deve essere fatta passare attraverso gli occhielli della tasca di inserimento (3) e attorno al carrello portaforca (↘).



È assolutamente necessario stabilire questa connessione. C'è il rischio che il dispositivo scivoli fuori dalle forche. **PERICO D'INCIDENTE!**

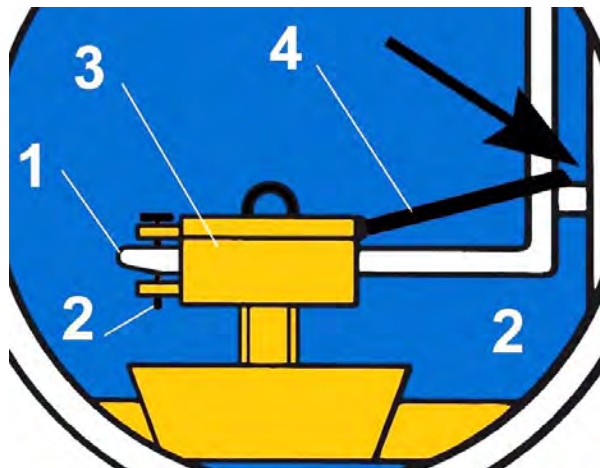
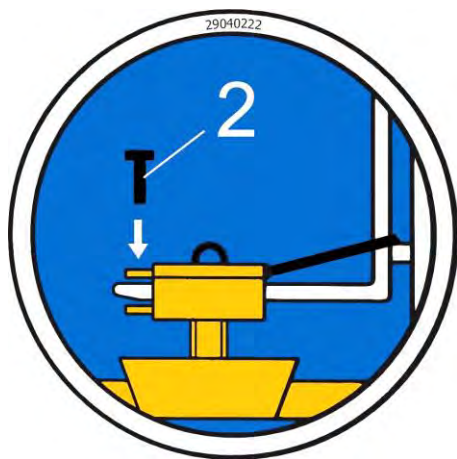

4.2 Installazione degli artigli di presa in acciaio WB-SQ

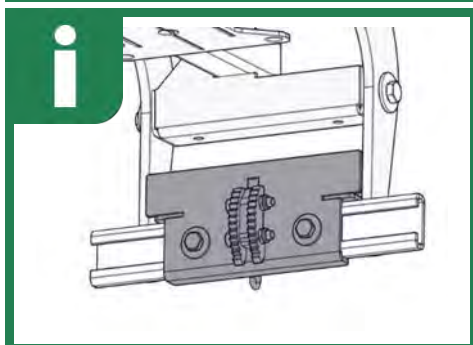
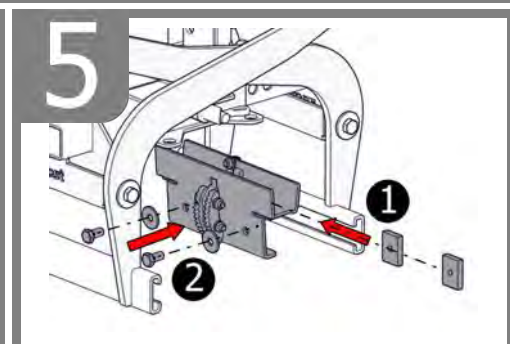
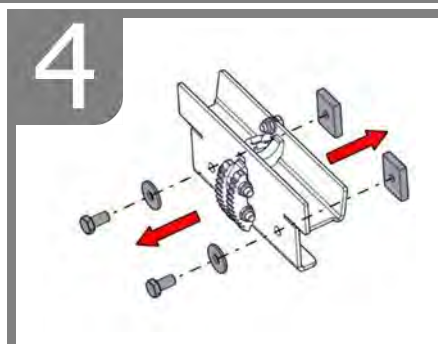
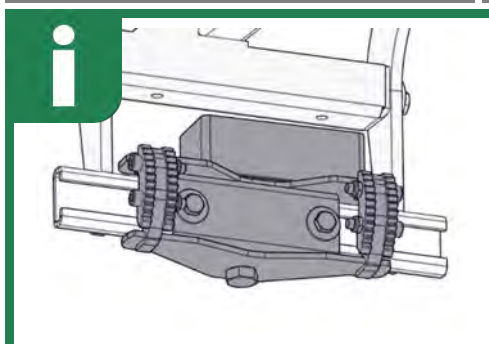
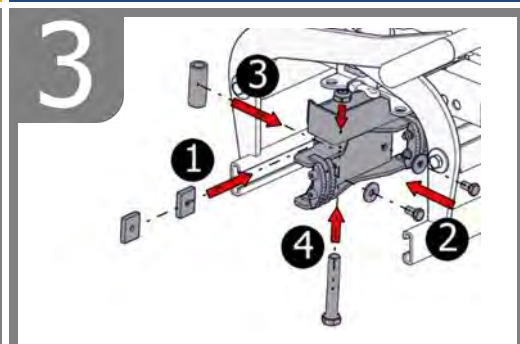
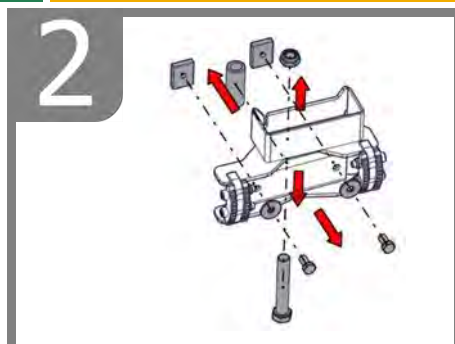
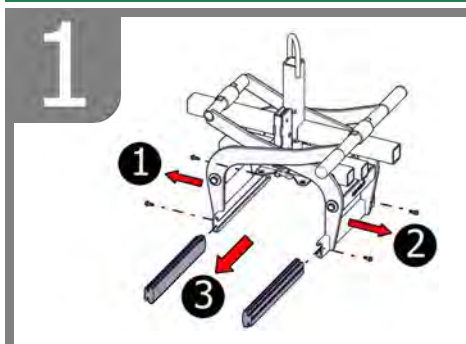
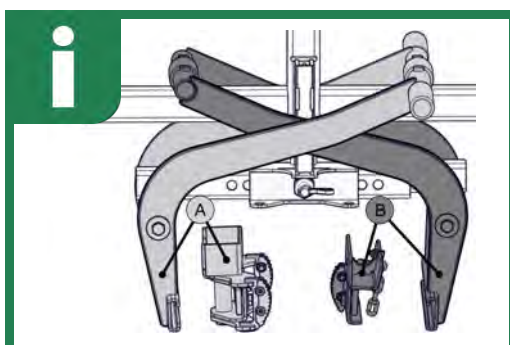
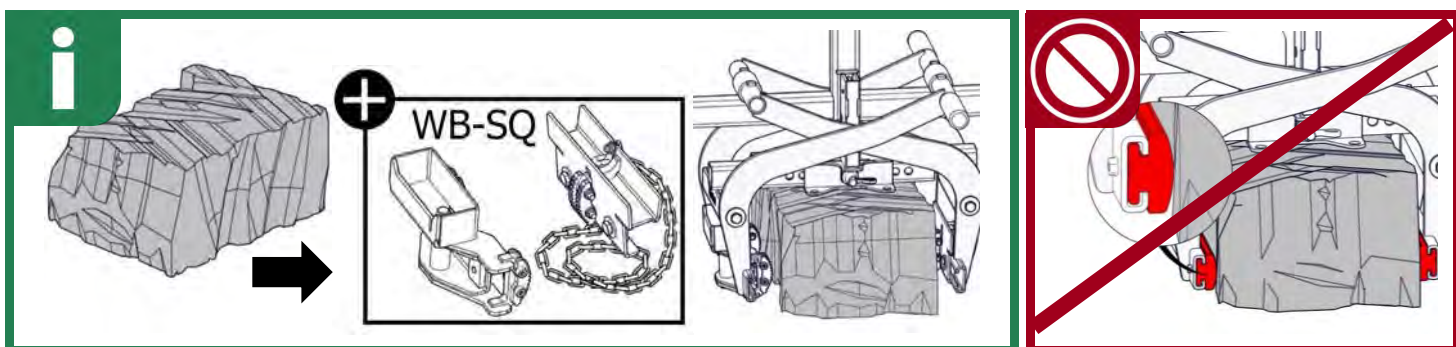

5 Regolazioni

5.1 Regolazione dell'ampiezza di presa (opzionale)

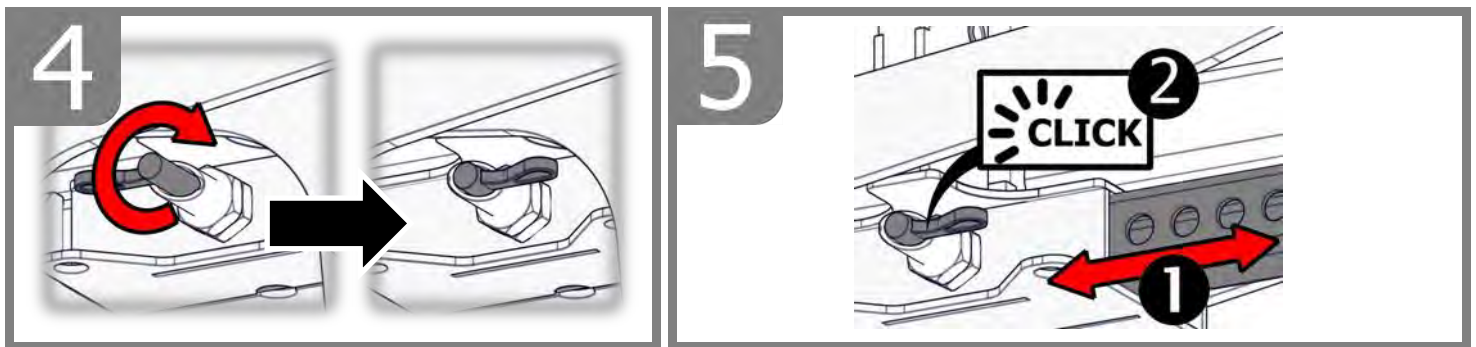
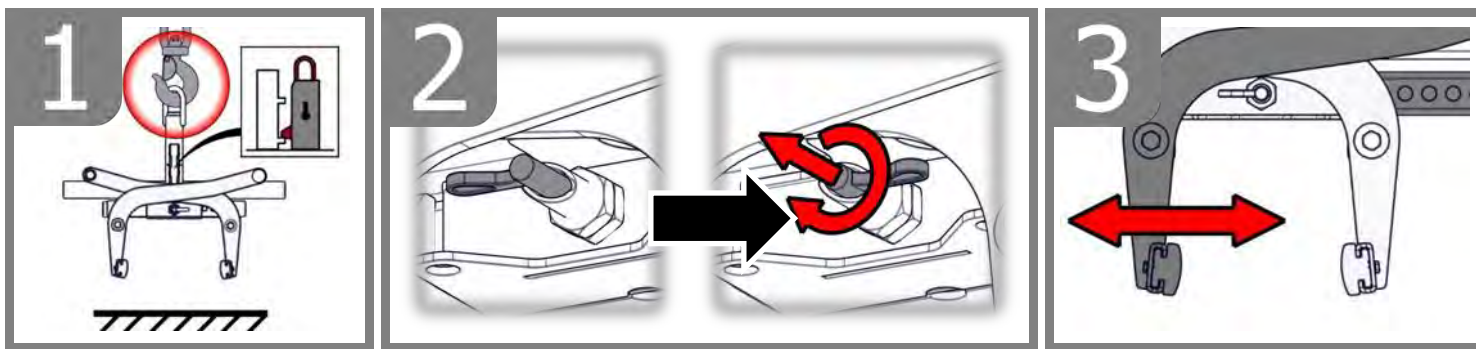
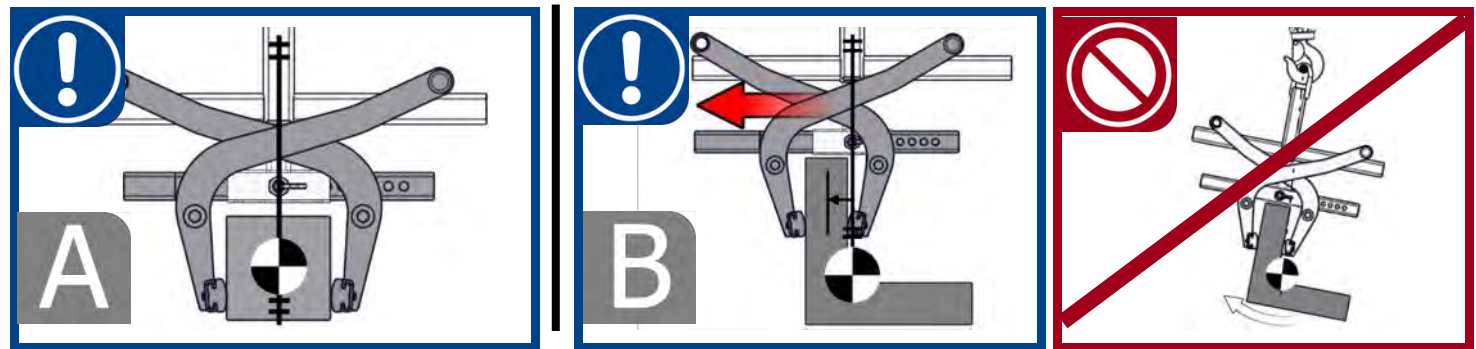
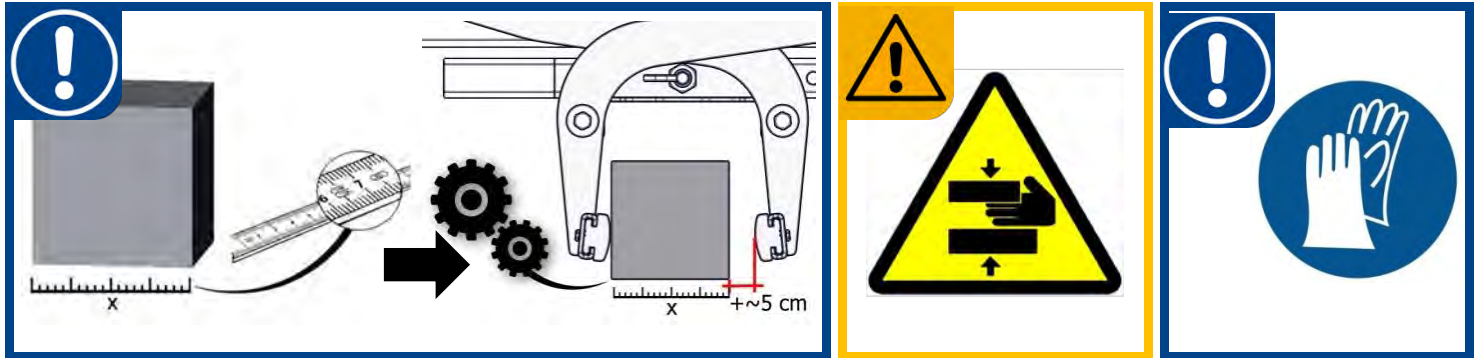

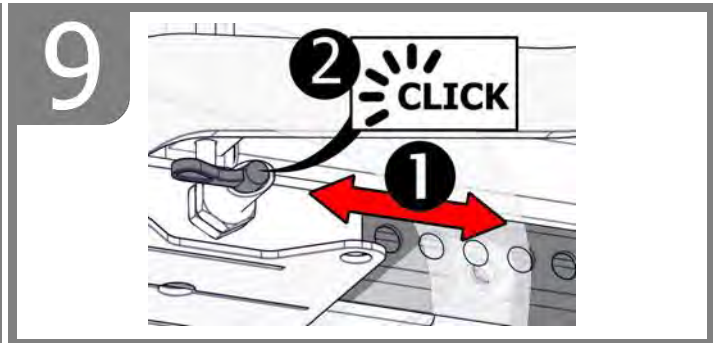
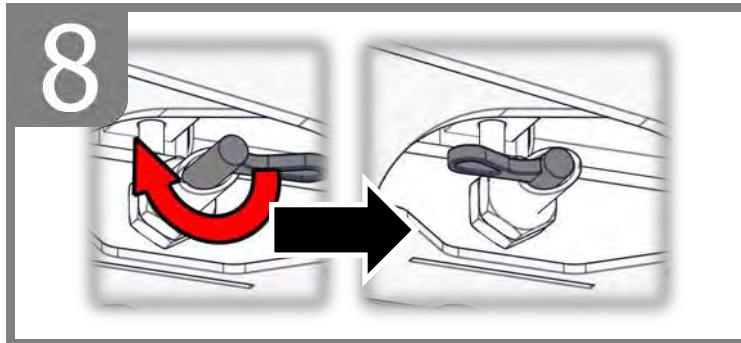
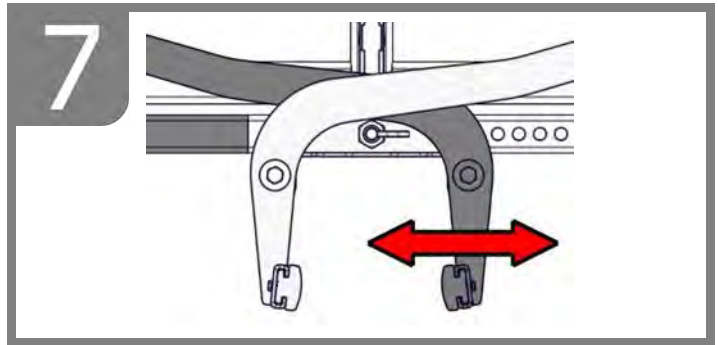
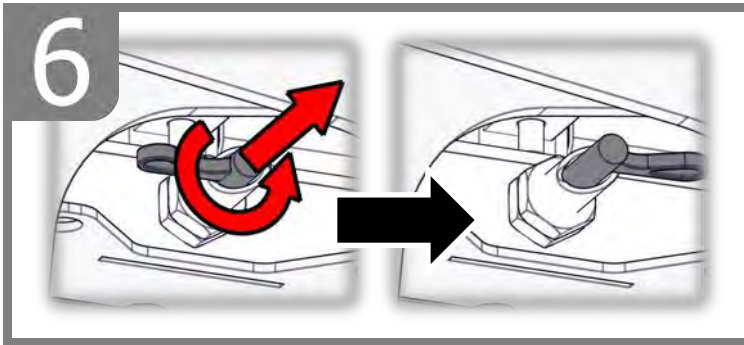

5.2 Accessori - HVA per la modalità batch

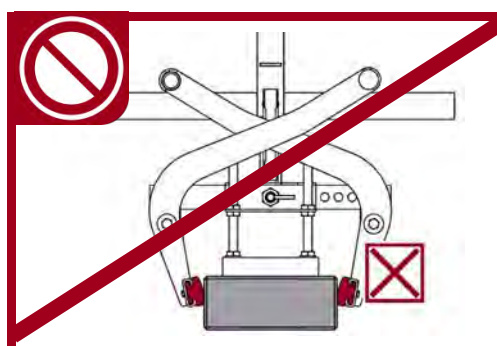
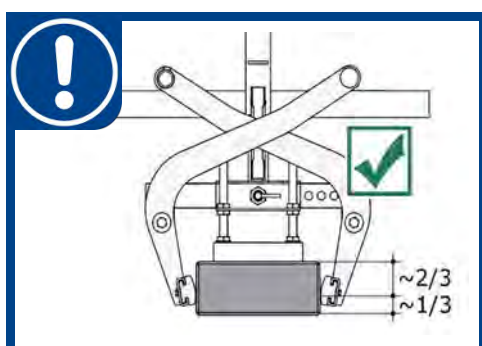
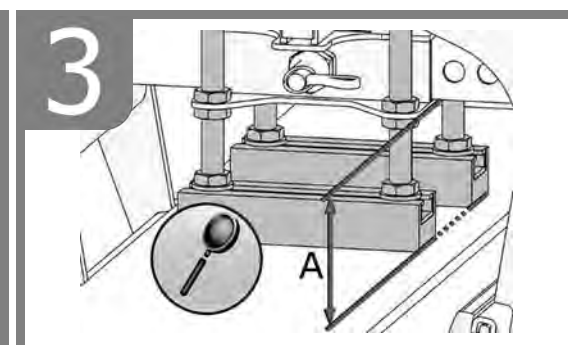
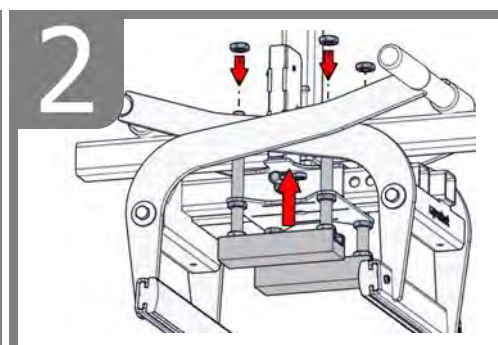
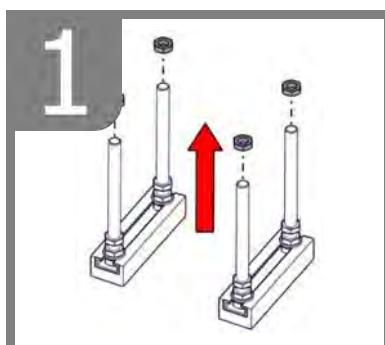
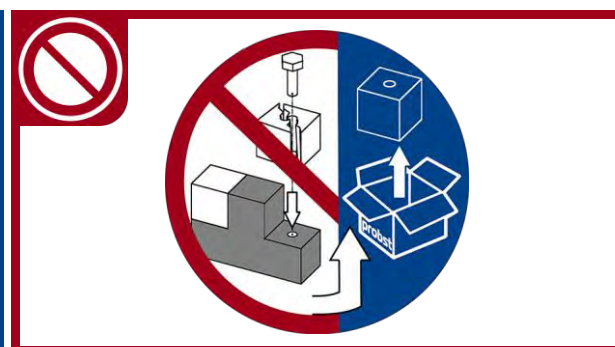
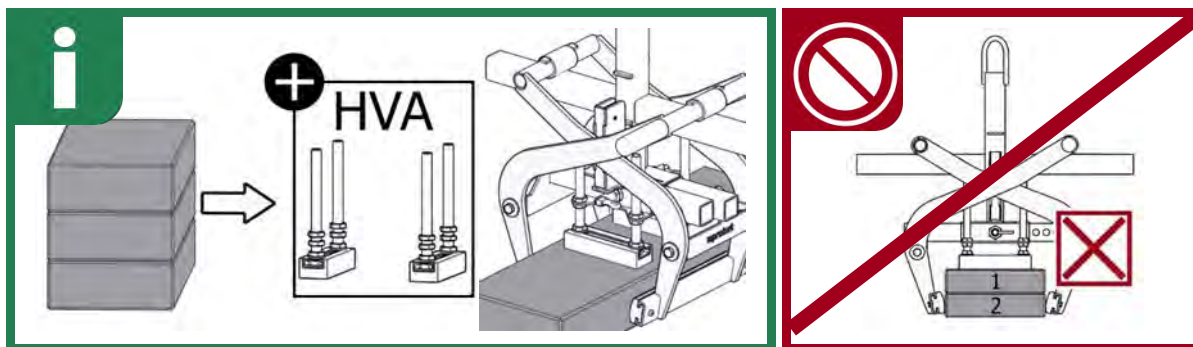

6 Funzionamento

6.1 Afferrare, spostare e depositare i carichi

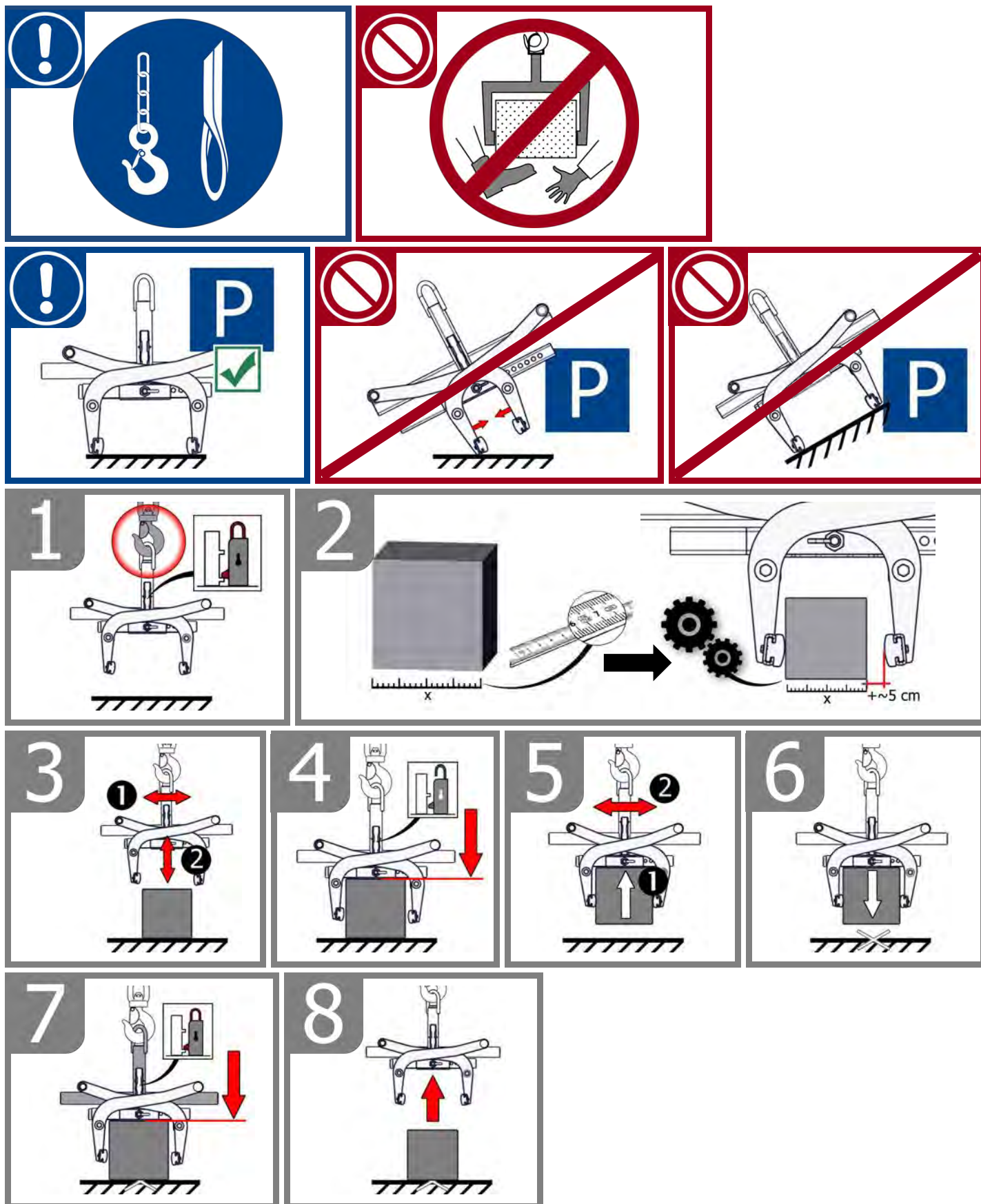

6.2 Figura del dispositivo di rilascio automatico

La pinza è dotata di un dispositivo di rilascio automatico, il che significa che l'apertura e la chiusura delle braccia di presa avvengono automaticamente al momento dell'abbassamento e del sollevamento della pinza.

Figure delle posizioni del dispositivo di rilascio automatico:

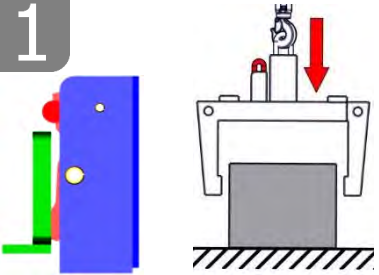
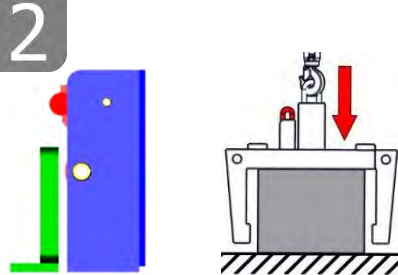
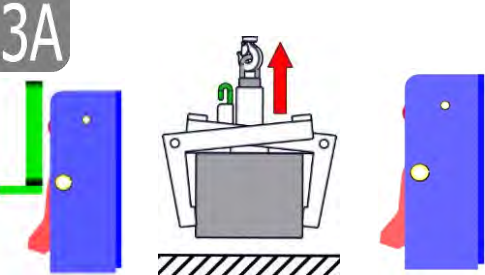
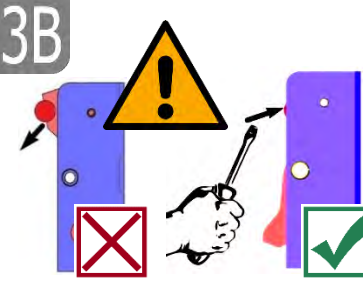
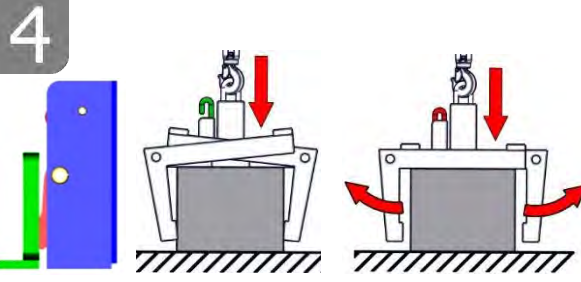
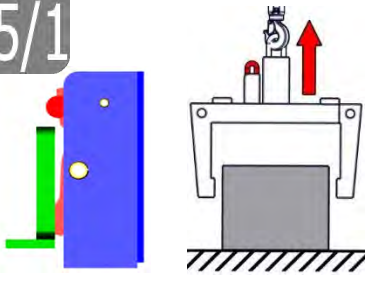
<p>1</p>  <ul style="list-style-type: none"> • La pinza è sollevata tramite la macchina operatrice. • Le braccia di presa sono aperte 	<p>2</p>  <ul style="list-style-type: none"> • La pinza è posizionata sopra all'elemento da sollevare. • Le braccia di presa sono aperte. 	<p>3A</p>  <ul style="list-style-type: none"> • La pinza è sollevata tramite la macchina operatrice. • L'elemento viene pinzato e può essere trasportato nella posizione a cui è destinato.
<p>3B</p>  <ul style="list-style-type: none"> • Nel caso di funzionamento errato, il Sistema di rilascio automatico deve essere reinserito manualmente (es. con un cacciavite) ¹⁾ 	<p>4</p>  <ul style="list-style-type: none"> • La pinza è posizionata a terra insieme all'elemento. • Le braccia di presa sono aperte. 	<p>5/1</p>  <ul style="list-style-type: none"> • La pinza è sollevata tramite la macchina operatrice. • Le braccia di presa sono aperte. • (Posizionamento dell'apparecchio sul terreno).



1) Se non si interviene sul difetto, il dispositivo di rilascio automatico si può danneggiare!
Il sollevamento e abbassamento brusco con o senza carico, la guida veloce con il dispositivo sulla macchina operatrice su terreni sconnessi è proibito.



Quando si sostituisce un meccanismo di rilascio automatico difettoso, assicurarsi che le fessure delle due spine siano sempre rivolte verso il basso. La posizione delle fessure non deve in nessun caso essere in cima o al centro, altrimenti c'è il pericolo che la rilascio automatico si blocchi durante la commutazione!

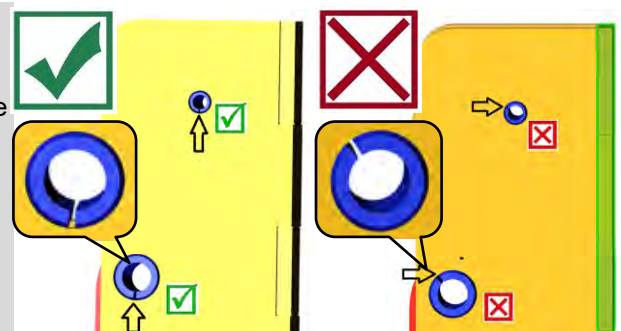

6.3 Funzionamento: Unghie di presa in acciaio WB-SQ

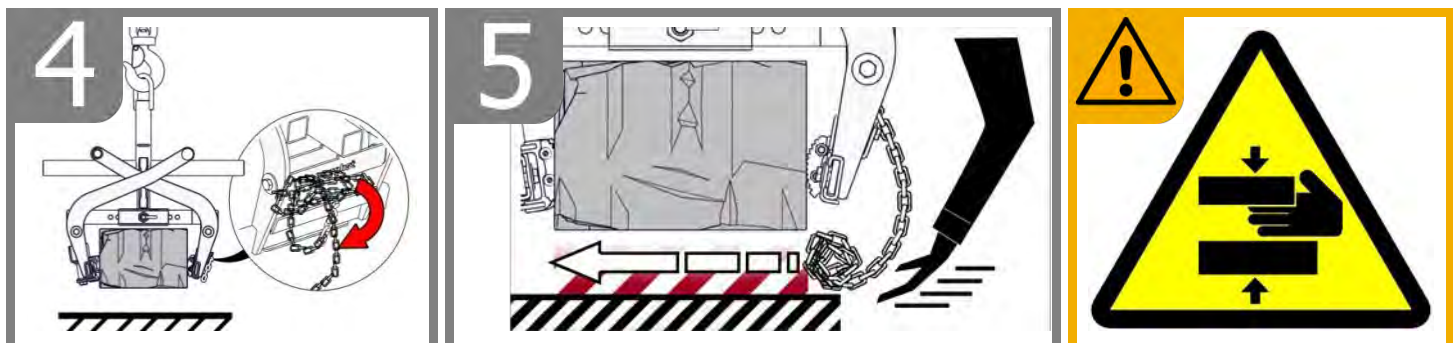
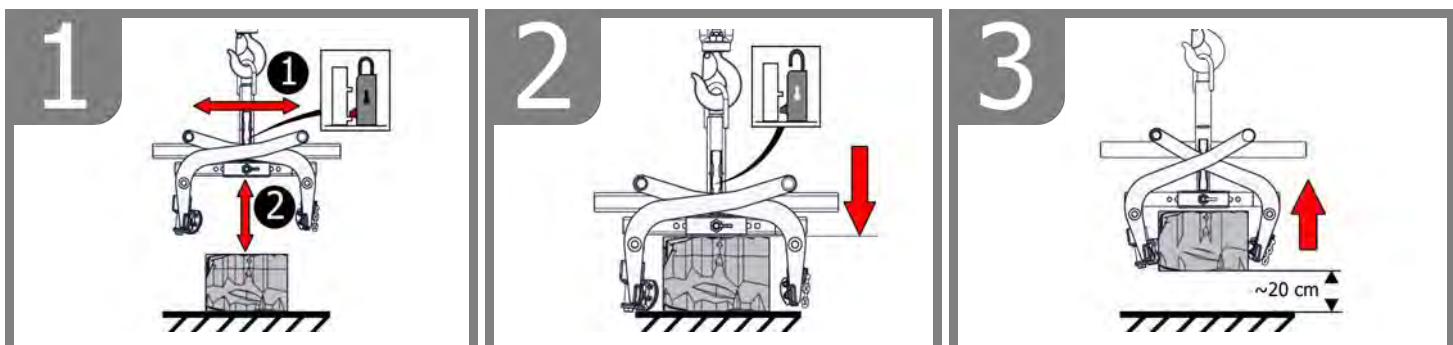
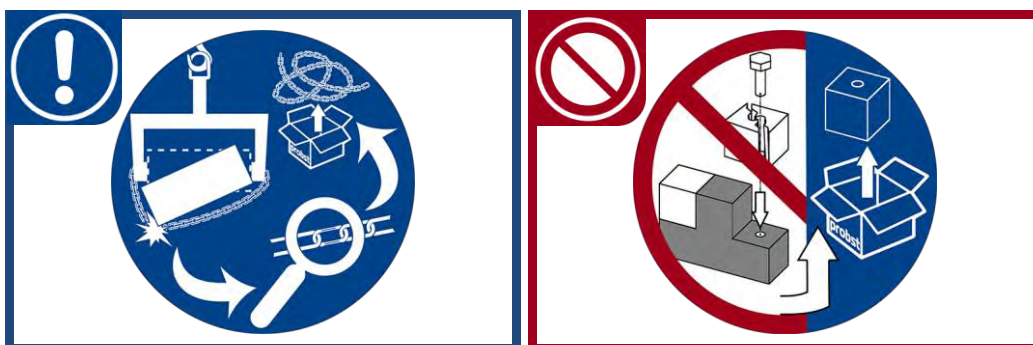
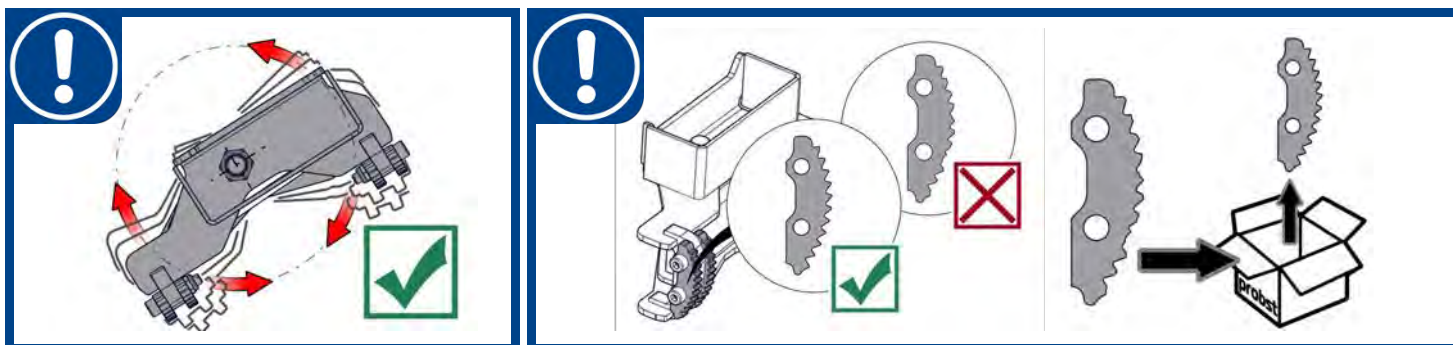

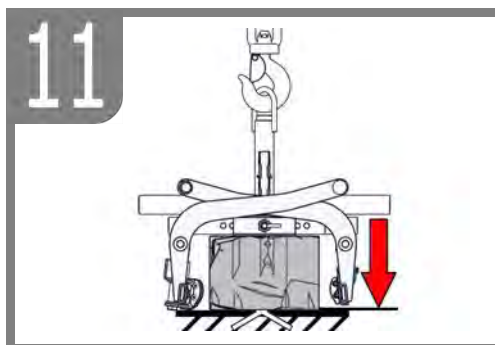
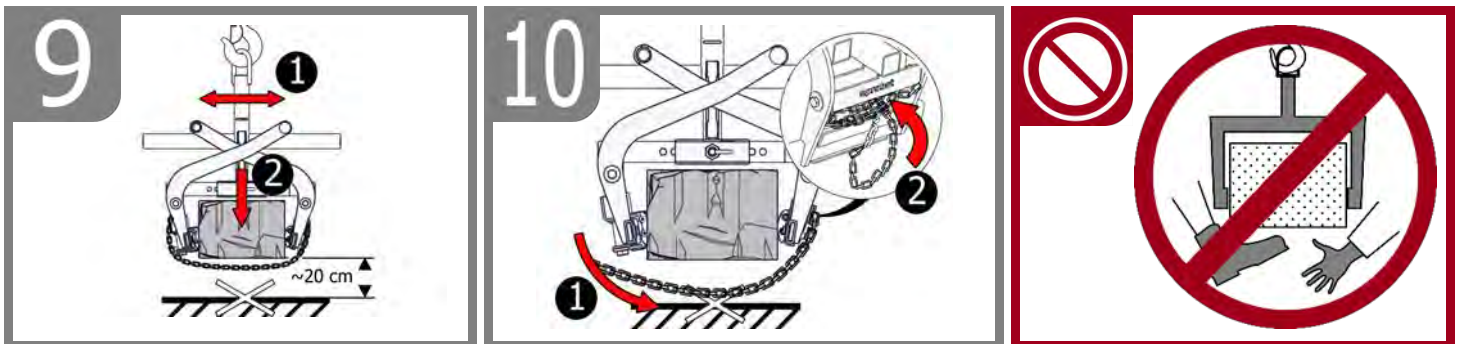
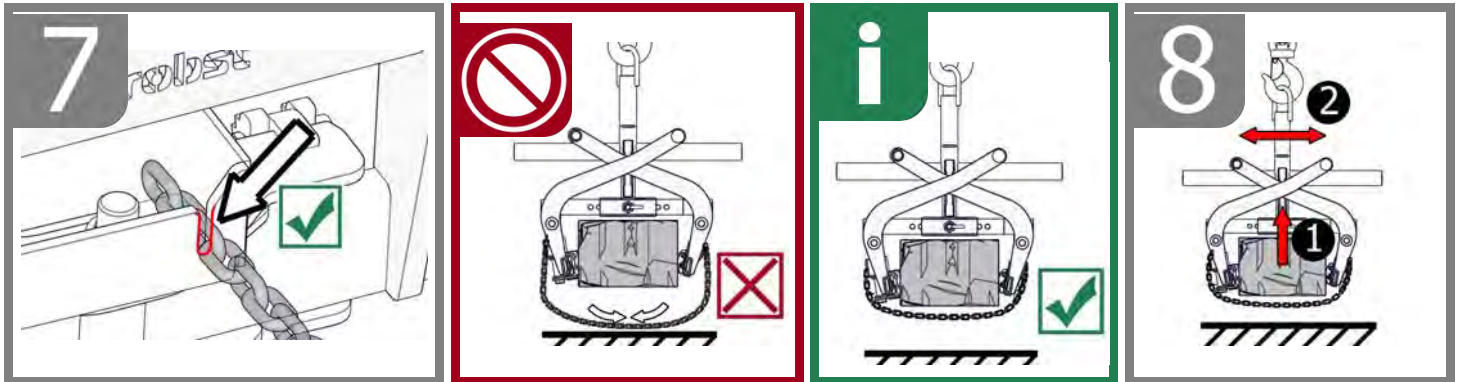

7 Cura e manutenzione

7.1 Manutenzione



Affinché l'apparecchio funzioni perfettamente e per garantire la sua sicurezza ed una lunga durata, è necessario effettuare le operazioni di manutenzione precisate nella tabella qui di seguito agli intervalli prescritti.

Utilizzare **solo parti di ricambio originali**, altrimenti decade la garanzia.



Per tutti i servizi di manutenzione l'apparecchio deve essere completamente spento!!!
Per tutte le operazioni bisogna assicurarsi che l'apparecchio non si chiuda inavvertitamente.
Pericolo di infortunio!!!

7.1.1 Meccanica

PERIODO DI MANUTENZIONE	Lavori da svolgere
Ispezione iniziale dopo 25 ore di funzionamento	<ul style="list-style-type: none"> Controllare o serrare tutte le viti di fissaggio (devono essere eseguite solo da una persona qualificata).
Ogni 50 ore di funzionamento	<ul style="list-style-type: none"> Serrare nuovamente tutte le viti di fissaggio (assicurarsi che le viti siano serrate secondo le coppie di serraggio valide delle corrispondenti classi di resistenza). Controllare il corretto funzionamento di tutti gli elementi di sicurezza esistenti (ad es. perni pieghevoli) e sostituire gli elementi di sicurezza difettosi. → 1) Controllare tutti i giunti, le guide, i perni e i pignoni, le catene per verificarne il corretto funzionamento, riaggiustarle o sostituirle se necessario. Controllare l'usura delle ganasce di presa (se presenti) e pulirle, se necessario sostituirle. Tutte le guide, cremagliere e le giunzioni esistenti di parti in movimento o componenti della macchina devono essere ingrassate / lubrificate per ridurre l'usura e per ottenere sequenze di movimento ottimali (grasso raccomandato: Mobilgrease HXP 462). Lubrificare tutti gli ingrassatori (se presenti) con l'ingrassatore.
Almeno 1x all'anno (accorciare l'intervallo di ispezione in caso di condizioni operative difficili)	<ul style="list-style-type: none"> Ispezione di tutte le parti di sospensione, nonché di bulloni e staffe. Ispezione di crepe, usura, corrosione e sicurezza funzionale da parte di un esperto.

1)

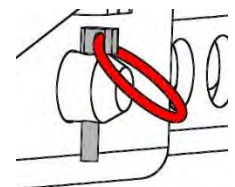
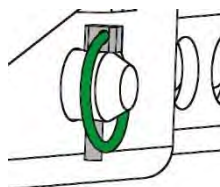

Barra del tampone



Controllare regolarmente lo sporco (ad es. Piccolo frammenti di pietra) nella parte superiore (vedi dettaglio nel punto „X“ nella Fig. 2) del tampone (6) → vedi Fig. 1 / Fig. 2

Problema: Lo sporco può danneggiare il tampone (6) durante la presa (quando piccoli frammenti di pietra vengono compressi nel tampone).

Soluzione: Rimuovere lo sporco in quest'area sul tampone (6), o nel caso vi sia tanto sporco, smontare e pulire il tampone.

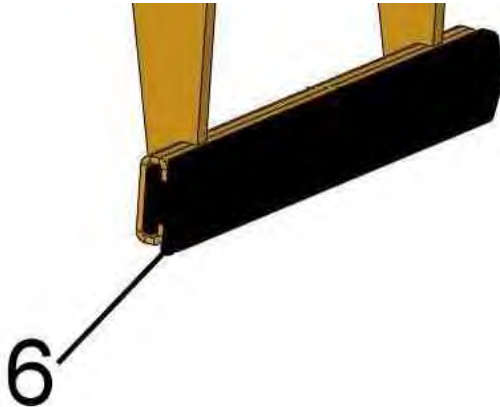

Fig. 1

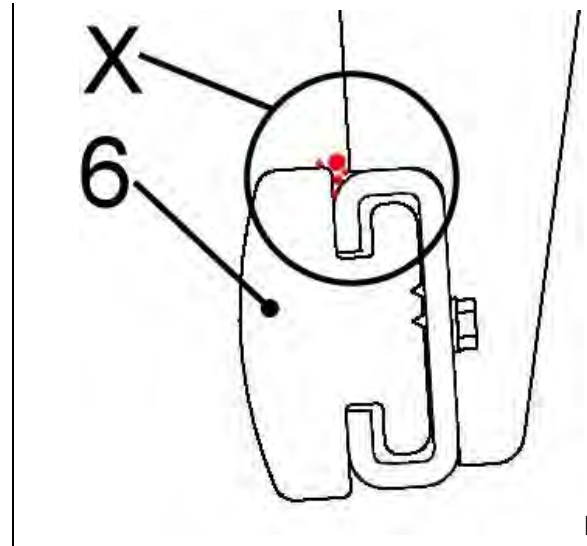

Fig. 2

7.1.2 Addizionali per ganasce con denti in acciaio (WB-SQ)

Prima di ogni utilizzo:	<ul style="list-style-type: none"> • Controllare tutti i denti in acciaio per la mobilità, usura e sporco. Denti usati (senza spigolo) o piegati devono essere sostituiti!
Regolarmente:	<ul style="list-style-type: none"> • Pulizia del dispositivo con idropulitrice (acqua calda).
Settimanalmente:	<ul style="list-style-type: none"> • Lubrificare e oliare parti mobili

RILASCIO AUTOMATICO



Non ingrassare mai con olio o grasso il rilascio automatico !

Pulire lo sporco visibile con idropulitrice ad alta pressione o con aria compressa !

7.2 Risoluzione dei problemi

GUASTO	CAUSA	RIMEDIO
La forza di presa è insufficiente ed il carico scivola.		
	<ul style="list-style-type: none"> Le ganasce della pinza presentano tracce di usura 	<ul style="list-style-type: none"> Sostituire le ganasce
	<ul style="list-style-type: none"> Il carico è superiore al peso massimo consentito 	<ul style="list-style-type: none"> Ridurre il peso del carico trasportato
(Impostazione del raggio di apertura) (opzionale)	<ul style="list-style-type: none"> L'angolo di apertura impostato è errato 	<ul style="list-style-type: none"> Impostare l'angolo di apertura in funzione del materiale che deve essere trasportato.
(Caratteristiche del materiale)	<ul style="list-style-type: none"> La superficie del materiale è sporca oppure la tipologia di materiale non è idonea/ammessa per questo apparecchio. 	<ul style="list-style-type: none"> Verificare la superficie del materiale oppure contattare il costruttore al fine di accertarsi che la tipologia di materiale sia adatta per questo apparecchio.
Il carico è sbilanciato		
	<ul style="list-style-type: none"> L'apparecchio non è stato caricato in modo simmetrico 	<ul style="list-style-type: none"> Regolare la posizione del carico affinché risulti simmetrica
(Impostazione dell'angolo di apertura)	<ul style="list-style-type: none"> Il raggio di apertura non è impostato simmetricamente 	<ul style="list-style-type: none"> Controllare e correggere l'impostazione del raggio di apertura.
Il meccanismo di rilascio automatico non funziona		
(Parte meccanica) (opzionale)	<ul style="list-style-type: none"> Il meccanismo di rilascio automatico non funziona 	<ul style="list-style-type: none"> Pulire il meccanismo di rilascio automatico con un pulitore ad alta pressione Correggere il funzionamento errato (→Vedi capitolo "Figura del dispositivo di rilascio automatico") Sostituire l'insero del meccanismo di rilascio automatico.

7.3 Riparazioni



- Gli interventi di riparazione dell'apparecchio possono essere eseguiti esclusivamente da persone che possiedono le conoscenze e la competenza necessarie.
- Prima di rimettere in funzione l'unità, **deve** essere effettuata un'ispezione straordinaria da parte di una persona qualificata o di un esperto.

7.4 Procedure di sicurezza



- L'azienda deve provvedere affinché l'apparecchio venga sottoposto all'ispezione di un esperto almeno una volta all'anno e che le anomalie riscontrate vengano tempestivamente eliminate (→ regolamento DGUV 100-500).
- Rispettare le disposizioni previste in materia dalle norme CE indicate nel certificato di conformità!!
- L'ispezione peritale può essere eseguita anche dal produttore Probst GmbH. Contattateci all'indirizzo: service@probst-handling.de
- Dopo l'esecuzione del controllo e l'eliminazione delle anomalie riscontrate sull'apparecchio raccomandiamo di applicare in un punto ben visibile la targhetta "Sachkundigenprüfung / Expert inspection". (Articolo-No.: 2904.0056+sticker di controllo con data)



Il controllo deve essere documentato da un esperto!

Apparecchio	Anno	Data	Esperto	Società

7.5 Indicazioni per l'etichetta identificativa



- Modello, numero di matricola e anno di produzione sono molto importanti per l'identificazione del vostro apparecchio. Se avete bisogno di informazioni in merito alle parti di ricambio, garanzia o altri dettagli specifici fate riferimento a queste informazioni.
- La capacità di portata massima (WLL) indica il carico Massimo che può essere sollevato con l'apparecchio. Non superare la capacità di portata (WLL) indicata.
- Se utilizzate l'apparecchio unitamente ad un'altra macchina operatrice (gru, argano, carrello elevatore, escavatore) tenete in considerazione anche il peso netto dell'apparecchio.



Esempio:

7.6 Indicazioni per il noleggio/leasing di attrezzature PROBST



Ad ogni noleggio/leasing delle attrezzature PROBST è obbligatorio includere le **istruzioni d'uso originali** (a seconda della lingua del paese dell'utilizzatore, verrà fornita in aggiunta la traduzione delle istruzioni d'uso originali)!

8 Smaltimento / riciclaggio di apparecchi e macchinari



Il prodotto può essere messo fuori servizio e preparato per lo smaltimento / riciclaggio **solo** da personale qualificato. I **singoli componenti** esistenti (come metalli, plastiche, liquidi, batterie/accumulatori ecc.) devono essere **smaltiti/riciclati in conformità alle leggi e alle norme di smaltimento specifiche del paese!**



Il prodotto non deve essere smaltito nei rifiuti domestici!

Certificato di manutenzione



Le richieste di garanzia sono valide solo se il programma di manutenzione specificato è stato adeguatamente rispettato (presso un officina specializzata). Dopo ogni intervento di manutenzione il seguente modulo deve essere compilato, timbrato e firmato e spedito a noi immediatamente. ¹⁾

¹⁾ via e-mail a: service@probst-handling.de / via fax o post

Operatore: _____
 Modello apparecchio: _____ Articolo N.: _____
 Apparecchio N.: _____ Anno di fabbricazione: _____

Prima ispezione dopo 25 ore di funzionamento

Data:	Lavoro di manutenzione:	Ispezione effettuata da:
		<i>Timbro</i>
	
		Nome / Firma

Dopo 50 ore di funzionamento

Data:	Lavoro di manutenzione:	Ispezione effettuata da:
		<i>Timbro</i>
	
		Nome / Firma
		Ispezione effettuata da:
		<i>Timbro</i>
	
		Nome / Firma
		Ispezione effettuata da:
		<i>Timbro</i>
	
		Nome / Firma

Minimo 1 volta all'anno

Data:	Lavoro di manutenzione:	Ispezione effettuata da:
		<i>Timbro</i>
	
		Nome / Firma
		Ispezione effettuata da:
		<i>Timbro</i>
	
		Nome / Firma

8 7 6 5 4 3 2 1

F

E

D

C

B

A

F

E

D

C

B

A

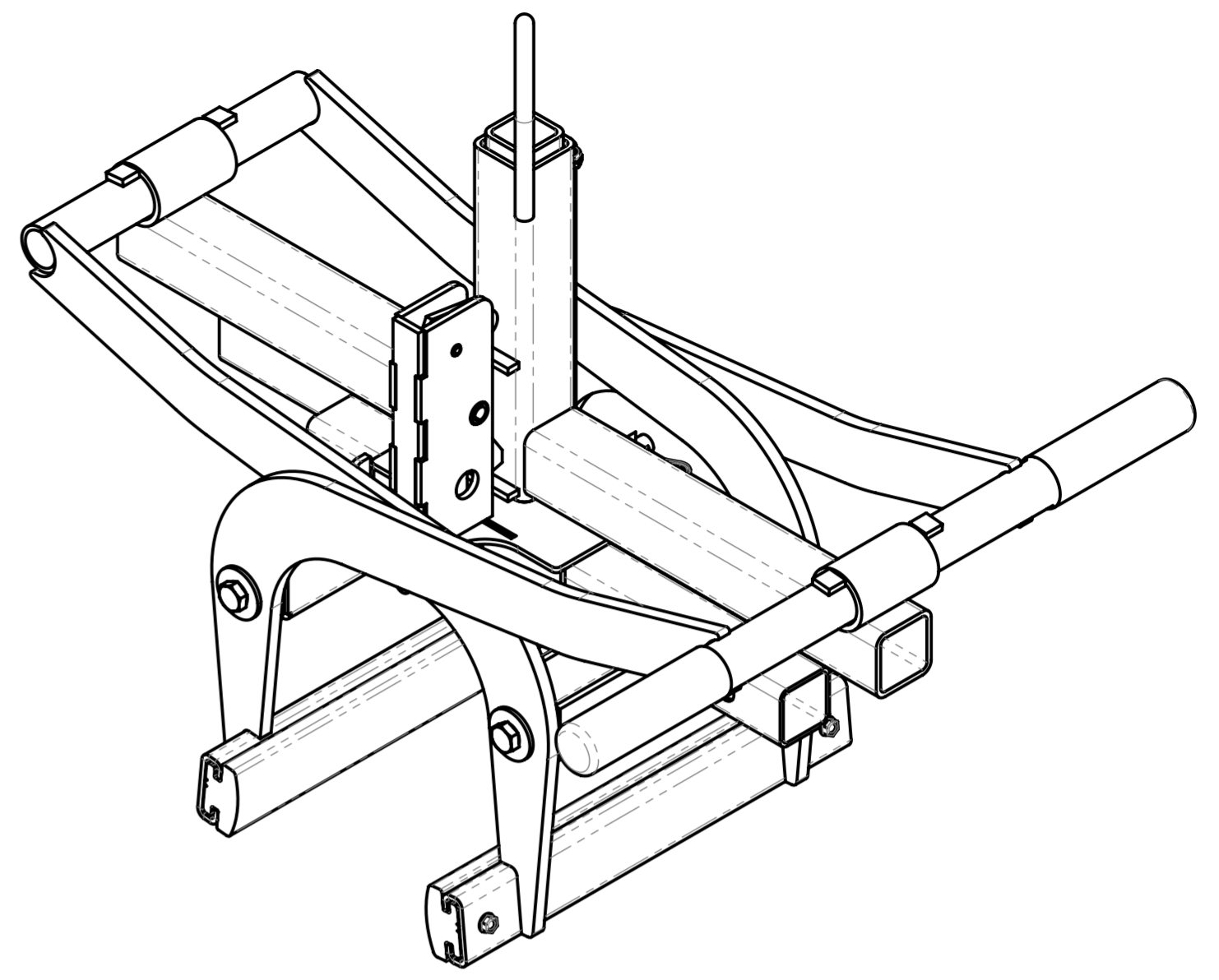
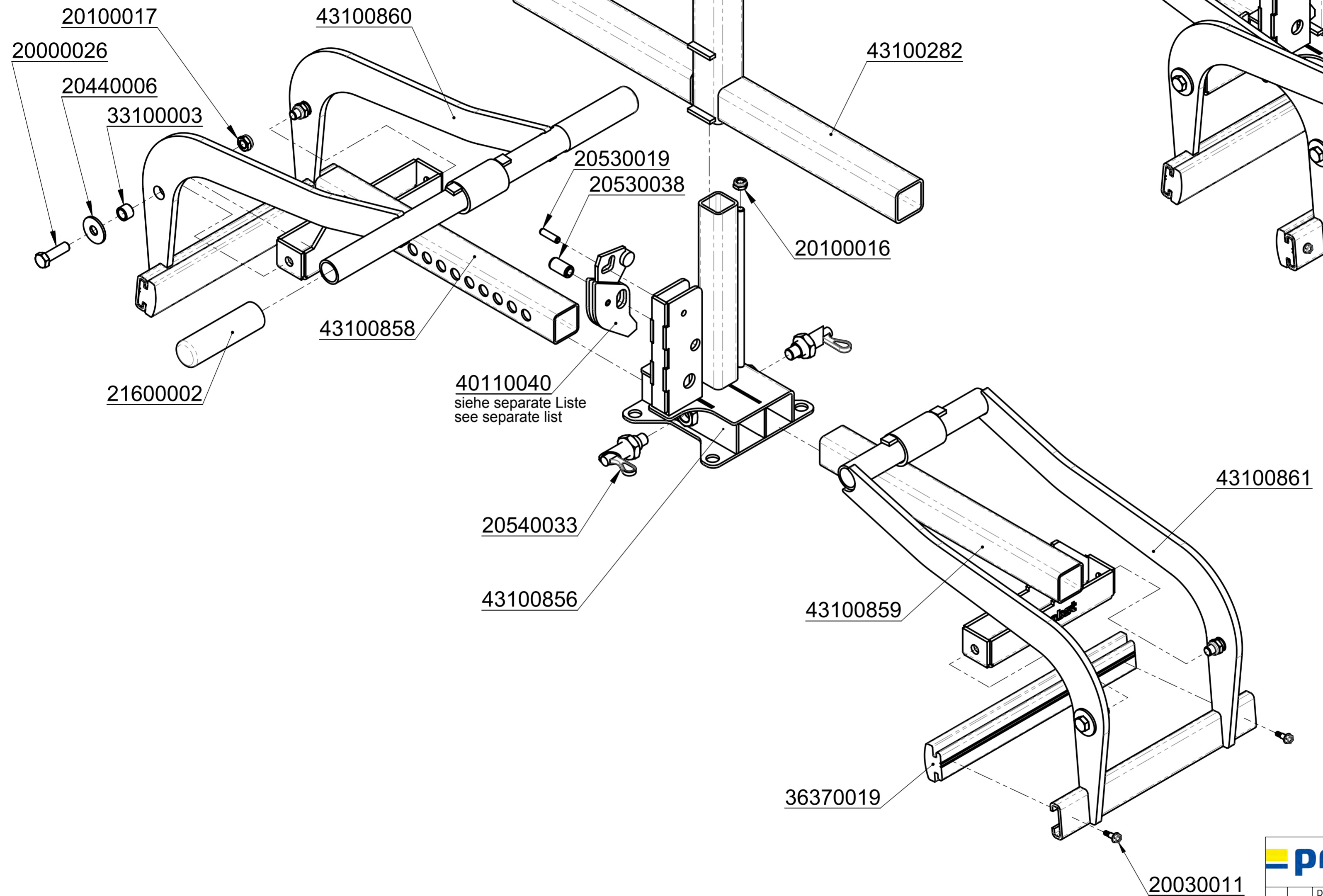

		© all rights reserved conform to ISO 16016	
Datum	Name	Benennung	
Erst. 18.10.2004	Klaus.Scholl	Trittstufenversetzzange	
Gepr. 3.6.2014	Joerg.Werner	TSZ-uni m. WA	
		Greifweite 50 - 600mm	
		Et. 185 mm, Tk 600 kg	
		Artikelnummer/Zeichnungsnummer	
		E53100338	
1			Blatt 1 von 1
Zust.	Urspr. 53100251	Ers. f.	Ers. d.

8 7 6 5 4 3 2 1

8

7

6

5

4

3

2

1

F

F

E

E

D

D

C

C

B

B

A

A

8

7

6

5

4

3

2

1

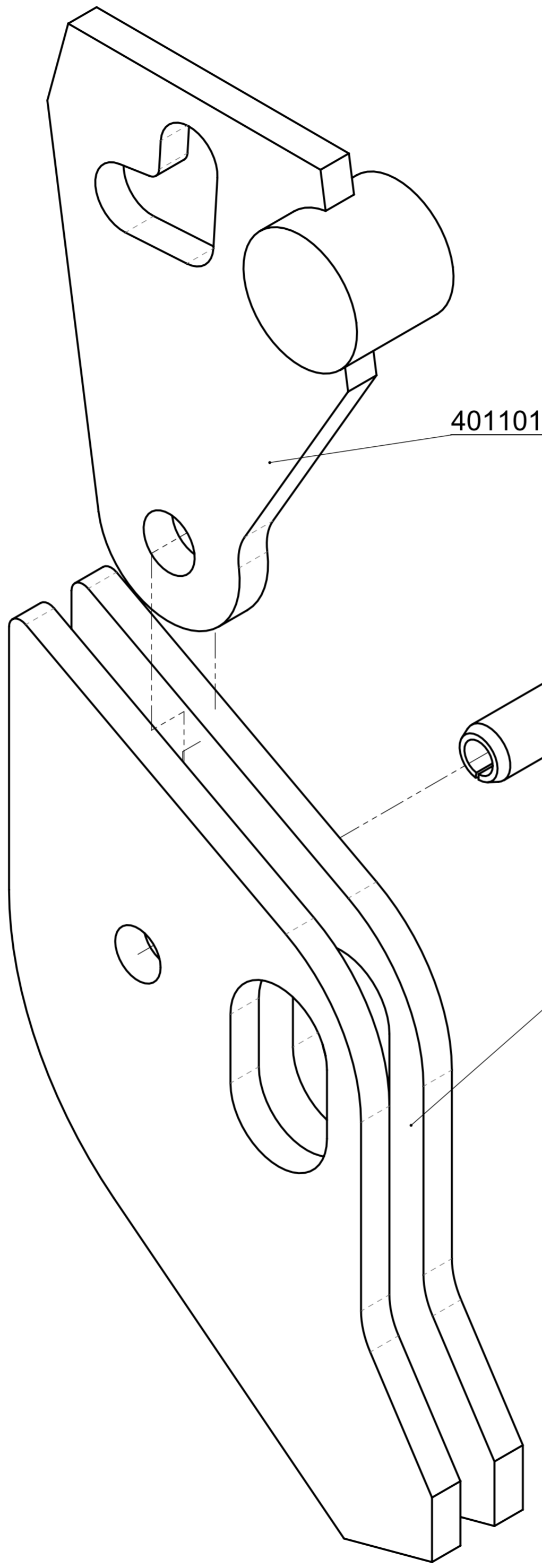

40110154

20530050

40110054

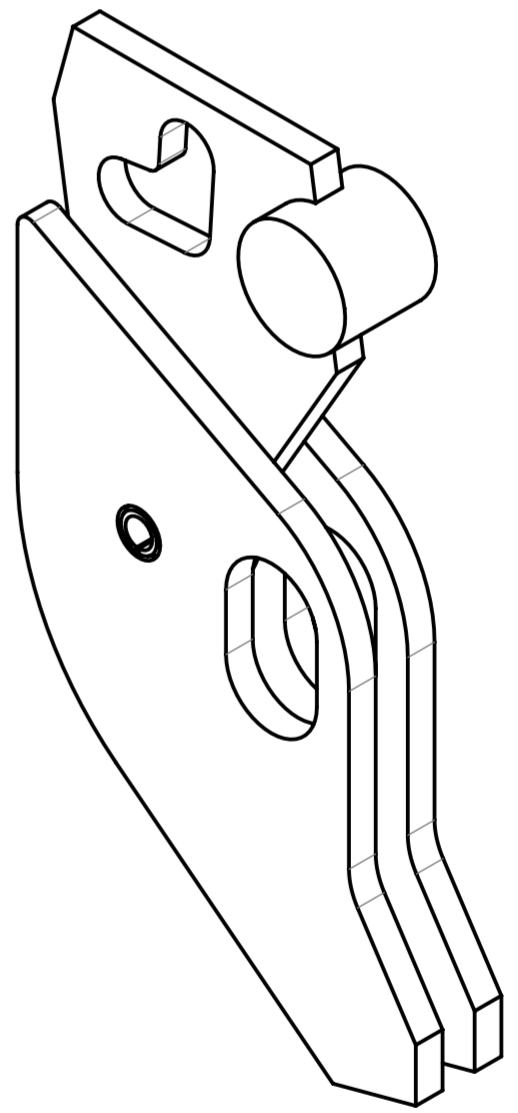

			© all rights reserved conform to ISO 16016	
	Datum	Name	Benennung	
	Erst. 24.8.2011	Perumal.Hurth	Einsatz für WA-L, komplett	
	Gepr. 24.9.2013	Joerg.Werner		
			Artikelnummer/Zeichnungsnummer	
			E40110040	
Zust.	Urspr. N236-1	Ers. f.	Ers. d.	Blatt 1 von 1



Typenschild Beispiel / Type plate example

Art-Nr.:	12345678	probst
SNr.:	31234567-00010-00001	
Baujahr/Year of manufacture:	20XX	
Eigengewicht/	00.000 kg/	Probst GmbH
Dead Weight:	00.000 lbs	Carlisle-Quadrat-Str. 6
Tragfähigkeit/	00.000 kg/	71720 Erdemühlhausen
Working Load Limit:	00.000 lbs	Germany
Greifbereich/	0.000-0.000 mm/	tel. +49 214 3309-0
Gripping Range:	00.000in	www.probst-handling.com
Entauchtiefe/	0.000 mm/	
Inside Height:	00.000in	



29040056



29040629

Auf beiden Seiten / on both sides

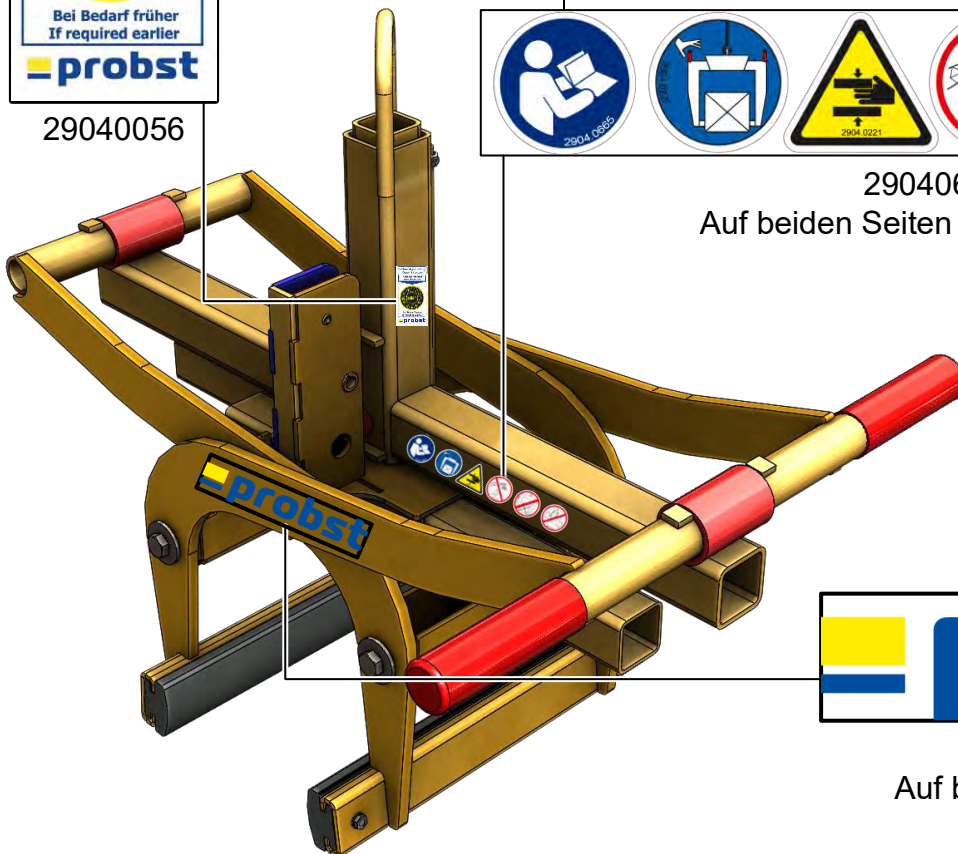

29040028

Auf beiden Seiten / on both sides