

# **Steerman Load Moving Systems**

*“Moving Loads the Professional Way”*

## **Operating Instructions for Caterpillar Skate Sets**

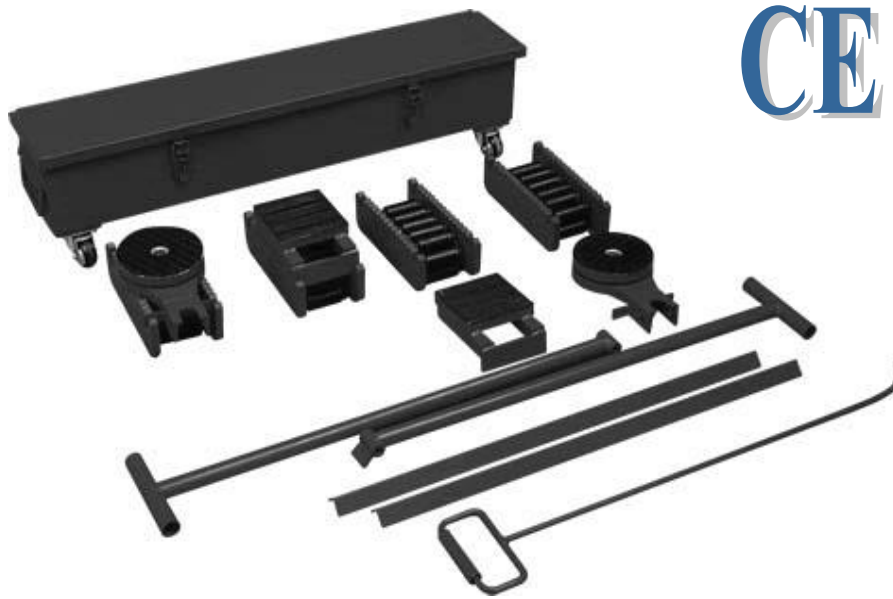

**Model: SCS-20 Capacity 20t**

**Model: SCS-30 Capacity 30t**

**Model: SCS-60 Capacity 60t**

**Before attempting to use this equipment please ensure that you read and fully understand the correct operating procedures.**



## INTRODUCTION...

***Thank you for choosing a Steerman SCS Caterpillar Skate set, which if maintained and operated correctly will provide you with many years of trouble free service.***

Please ensure that these instructions are made available to all those who will operate or maintain the skates.

For your personal safety, please read and fully understand the information contained within.

The owner/operator shall have an understanding of this product and its correct operation before attempting to use the skates.

The owner/operator must understand the inherent dangers associated with the use and misuse of this type of product.

If any doubts arise as to the safe and proper use of this product as outlined in this manual, remove the equipment from service until such time as it is clear.

Inspect the skates before each use and report any defects immediately to the person responsible for the maintenance.

Do not use if any of the following is evident. Bent, cracked, missing or broken components.

If the skates have been, or are suspected of having been subjected to shock loading, discontinue use until the units has been checked by a qualified person or returned to the manufacturer or his authorised agent for investigation.

Owners/operators of this equipment need to be aware that the use and subsequent repair of this equipment may require some special training, knowledge and test equipment.

It is recommended that skates undergo annual inspection by a qualified person and that any damaged or missing parts, warning labels or safety signs must be replaced by factory approved genuine **Steerman** replacement parts only.

Any skate that appears to be damaged in any way, is worn or operates abnormally should be removed from service immediately until such time as permanent, effective repairs can be made.

**WARNING!**  
**ALWAYS READ AND FULLY UNDERSTAND**  
**THE CORRECT OPERATING**  
**PROCEDURES PRIOR TO USE**

### **PRODUCT DESCRIPTION**

***Steerman SCS-20, SCS-30 and SCS-60 Caterpillar Skates*** are designed for the movement of heavy loads over flat even surfaces. With capacities of 20t, 30t, and 60t it is the operator's responsibility to decide the correct capacity for each specific application. Whenever possible it is advisable to run the units over a flat steel-plated surface, channel sections or rails. The harder the operating surface the less rolling resistance is encountered making the load easier to move.

***There is serious risk of personal injury if you do not follow all instructions detailed in this booklet.***

Steerman equipment has been designed to be used by an able bodied, competent adult who has read and fully understood these warnings and instructions. The equipment **MUST NOT** be used to carry or lift personnel.

Make sure that you know how to operate this equipment safely and are aware of its limitations before attempting to use it. Make sure that everyone in the immediate work area is warned of what you are doing and is aware of the path you plan the load to take.

## ALWAYS...

**Always** wear practical, protective clothing, gloves and footwear. Avoid loose garments and jewellery that could catch in moving parts, and tie back long hair.

**Always** check that the rollers are free from any embedded debris before using the system.

**Always** use on smooth level surfaces - plated steel floors are recommended. The load must always be evenly distributed on the system.

**Always** use some form of anti-slip mat or wooden board between the skate surfaces and the load.

**Always** keep hands and feet well clear of all areas beneath the load being raised, lowered or carried.

**Always** operate the equipment within its capacity. **DO NOT OVERLOAD.**

**Always** keep fingers clear of the skate rollers when lifting the system. The rollers are designed to rotate.

**Always** avoid shock loading when positioning or carrying industrial loads.

**Always** use appropriately rated jacks to lift and lower loads onto the Steerman Caterpillar Skate System rather than lowering directly from a crane or fork lift truck.

**Always** ensure that the rear skates are kept parallel to the load and the line of direction by means of the alignment bar supplied.

**Always** keep children, animals and bystanders away from the work area. Cordon off a **NO-GO** area with cones, barriers or tapes.

## DO NOT...

**Do not** use the equipment until you have read and fully understood these instructions.

**Do not** operate the equipment if you are ill, feeling tired, or under the influence of alcohol or drugs.

**Do not** operate the equipment until you have checked that no damage to the system has occurred from previous use and that the system has been correctly reassembled.

**Do not** operate the equipment until you have ascertained that the weight and centre of gravity of the load being carried is in the centre of the 3-point loading system.

**Do not** attempt to raise loads when they are close to ceilings or other overhead obstructions.

**Do not** operate the equipment until you have ensured that the load is balanced, stable and that all personnel are standing clear of the load and the intended route of travel.

**Do not** operate the equipment on uneven or inclined surfaces.

**Do Not**

Continued:

**Do not** allow hands, arms or feet to be directly under the load at any time.

**Do not** operate the equipment where contact with acids, alkalis or strong solvents is likely.

**Do not** operate the equipment over rough uneven surfaces, floor joints, sliding door tracks, manhole covers, tarmac or asphalt.

**Do not** operate the equipment over any surface that is unable to adequately support the combined weight of the load and the system.

## OPERATING INSTRUCTIONS...

**Getting Started:**

Ensure that you have selected a set of Steerman Caterpillar skates that are designed to carry the full weight of your intended load.

Ensure that you have all the necessary lifting jacks, restraining equipment and pulling or pushing devices needed for the job.

Assess the shape of the load to determine the best position for the skates. **REMEMBER** the load must rest evenly on the three or four point skate pads, with the weight evenly distributed over all three or four points.

Always raise the rear part of the load first, using appropriately rated hydraulic claw jacks, then place the two rear trolleys in position. Ensure that some form of anti-slip mats or wooden boards are in place between the load and the tops of the trolleys. The alignment bar should be positioned perpendicular to the direction of the travel to avoid "crabbing" when the load is moved. Carefully lower the load onto the rear trolleys and remove the jacks.

Next, Jack up the front of the load using appropriately rated hydraulic claw jacks and position the front steering unit/s-fitted with a turntable under the load ensuring that all hands and fingers are not above the top surface of the trolley. Again ensure that the anti-slip mats or wooden boards are in place on the turntable pads.

Lower the load onto the steerable front unit/s and double check that the load is evenly distributed and safely balanced.

Check that the route to the final destination of the load is clear of debris and personnel and that the surface is suitable for both the weight of the load being carried **and** the system.

Totally clear and clean the floor area and over the whole route to be travelled. Remove all grease, metal shavings, and any other forms of debris. **REMEMBER**, Steerman skates have only been designed to operate over smooth flat industrial floor surfaces.

**Basic Techniques:**

The front skate/s must not be steered whilst the load is stationary. Steering can only really occur when the load is moving.

When the system is moving, always position yourself so that you can effectively control the skates while at all times staying clear of the load.

**Basic Techniques:**

Continued...

Extreme care should be taken to ensure that any operator, marshall or bystander does not get trapped between the load and any surrounding walls or obstructions.

When pushing or pulling with a powered vehicle, secure a restraint cable or suitable sling to the load to prevent it running away.

The operator should be within sight of any powered vehicle driver at all times. If this is not possible, a third person should be used to relay instructions between the operator and the driver.

Whenever possible it is of great help to mark the floor to show the exact route the load will travel along and to mark where it is to be finally positioned.

Check the path for debris before the operation and continually check in front and behind you as you steer to make sure there is no danger of tripping or falling.

Do not allow the load system to travel at speed or abruptly change its direction of travel.

**FINALLY...**

To remove the Steerman skate system from beneath the load, the load should be raised on appropriately rated hydraulic claw jacks until it is just clear of the top surface of the system. The front steer unit should be removed first and the load carefully lowered to the floor before attempting to remove the rear units.

Next, the rear trolleys should be removed and the load carefully lowered to the ground whilst under total control.

Before manually lifting any part of the Steerman Caterpillar Skate System, check that the component weight does not exceed 20kgs (44lbs).

**Take your time and exercise extreme care. You are more likely to have an accident if you are tired or rushing to complete any operation.**

**BRIEF SPECIFICATIONS...**

Model	Capacity Kg	O/A Height to Top of Turntable	Turntable Diameter	Roller Diameter	Weight of Set
SCS-20	20,000	108mm	130mm	18mm	50kg
SCS-30	30,000	117mm	130mm	24mm	58kg
SCS-60	60,000	140mm	150mm	30mm	92kg

### EC Declaration of Conformity

In accordance with Machinery Directive 2006/42/EC (Appendix 11A)

Manufacturer: - **Steerman Load Moving Systems**  
**Columbus Mckinnon Corporation Ltd, Knutsford Way, Sealand Industrial Estate. Chester CH1 4NZ UK**

Hereby declare, that the design, construction and commercial execution of the equipment noted below complies with the essential health and safety requirements of the EC Machinery Directive. The validity of this declaration will cease in cases of unauthorised modification without prior written agreement from the company. Furthermore, validity of this declaration will cease in the case of the equipment not being correctly used and maintained in accordance with the supplied operating instructions.

Machine Description: - Steerman range: SCS-20, SCS-30, SCS-60  
Heavy Duty Caterpillar Skates.

Machine Type: - Industrial Machinery and Heavy Load  
Moving Skates.

Serial Number: - From manufacturing year 10/04 (serial numbers for  
the individual capacities/models are registered in the  
production book with the CE sign).

Relevant  
EC Directives: - EC Machinery 2006/42/EC

Transposed harmonised  
Standards in particular: - EN 349: 1993+A1: 2008 Safety of machinery-  
Minimum gaps to avoid crushing of parts of the  
human body

ISO 12100:2010 general principles for design-Risk  
Assessment and risk reduction



N J Hancocks QA & Technical Manager  
Steerman Load Moving Systems

October 2010