

CM 35 Mini Clipper

OPERATING INSTRUCTIONS

Translation of the original Instructions





CE Declaration of conformity

The undersigned manufacturer:

SAINT - GOBAIN ABRASIVES S.A.
190, BD. J. F. KENNEDY
L-4930 BASCHARAGE

Declares that this product:

Masonry saw: **CM 35 Mini Clipper 230V**
CM 35 Mini Clipper 110V UK

Code: **70184603115**

Code: **70184607578**

Is in conformity with the following Directives:

- **"MACHINES" 2006/42/CE**
- **"LOW VOLTAGE" 2014/35/UE**
- **"ELECTROMAGNETIC COMPTABILITY" 2014/30/UE**
- **"NOISE" 2000/14/CE**

And European standard :

- **EN 12418 – Masonry and stone cutting-off machines – Safety**

Valid for machines as of serial number :

1801XXXXX

Storage site for the technical documents :

Saint-Gobain Abrasives 190, Bd. J. F. Kennedy 4930 BASCHARAGE, LUXEMBOURG

This declaration of conformity loses its validity when the product is converted or modified without agreement.

Bascharage, Luxembourg, the 15.05.2018 :

François Chianese, executive officer.

CM 35 Mini Clipper

OPERATING INSTRUCTIONS

TABLE OF CONTENTS

<u>1</u>	<u>BASIC SAFETY INSTRUCTIONS.....</u>	<u>6</u>
1.1	<i>Symbols</i>	6
1.2	<i>Machine plate.....</i>	7
1.3	<i>Safety instructions for particular operating phases.....</i>	7
<u>2</u>	<u>MACHINE DESCRIPTION</u>	<u>8</u>
2.1	<i>Short description.....</i>	8
2.2	<i>Purpose of use</i>	8
2.3	<i>Layout</i>	8
2.4	<i>Technical data</i>	10
2.5	<i>Statement regarding the vibration emission</i>	11
2.6	<i>Statement regarding noise emission</i>	12
<u>3</u>	<u>ASSEMBLY AND COMMISSIONING</u>	<u>13</u>
3.1	<i>Tool assembly</i>	13
3.2	<i>Electrical connections.....</i>	13
3.3	<i>Starting the machine</i>	13
<u>4</u>	<u>TRANSPORT AND STORING</u>	<u>14</u>
4.1	<i>Securing for transport.....</i>	14
4.2	<i>Transportation procedure.....</i>	14
4.3	<i>Long period of inactivity</i>	14
<u>5</u>	<u>OPERATING THE MACHINE</u>	<u>15</u>
5.1	<i>Jobsite.....</i>	15
5.2	<i>Cutting methods</i>	15
<u>6</u>	<u>MAINTENANCE AND SERVICING</u>	<u>18</u>
<u>7</u>	<u>FAULTS : CAUSES AND CURES</u>	<u>19</u>
7.1	<i>Fault-finding procedures</i>	19
7.2	<i>Trouble-shooting guide.....</i>	19
7.3	<i>Circuit Diagram 230V</i>	20
7.4	<i>Circuit Diagram 110V</i>	21
7.5	<i>Customer service</i>	22
7.6	<i>Spare parts.....</i>	23

1 BASIC SAFETY INSTRUCTIONS

The CM 35 Mini clipper is exclusively designed for the cutting of construction products with Norton diamond blades, mainly on construction sites.

Uses other than the manufacturer's instructions shall be considered as contravening the regulations. The manufacturer shall not be held responsible for any resulting damage. Any risk shall be borne entirely by the user. Observing the operating instructions and compliance with inspection and servicing requirements shall also be considered as included under use in accordance with the regulations.

1.1 Symbols

Important warnings and pieces of advice are indicated on the machine using symbols. The following symbols are used on the machine:



Read operator's instructions



Ear protection must be worn



Hand protection must be worn



Eye protection shall be worn

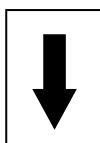

Rotation direction of the blade



Danger: risk of cut

1.2 Machine plate

Important data can be found on the following plate located on the machine:

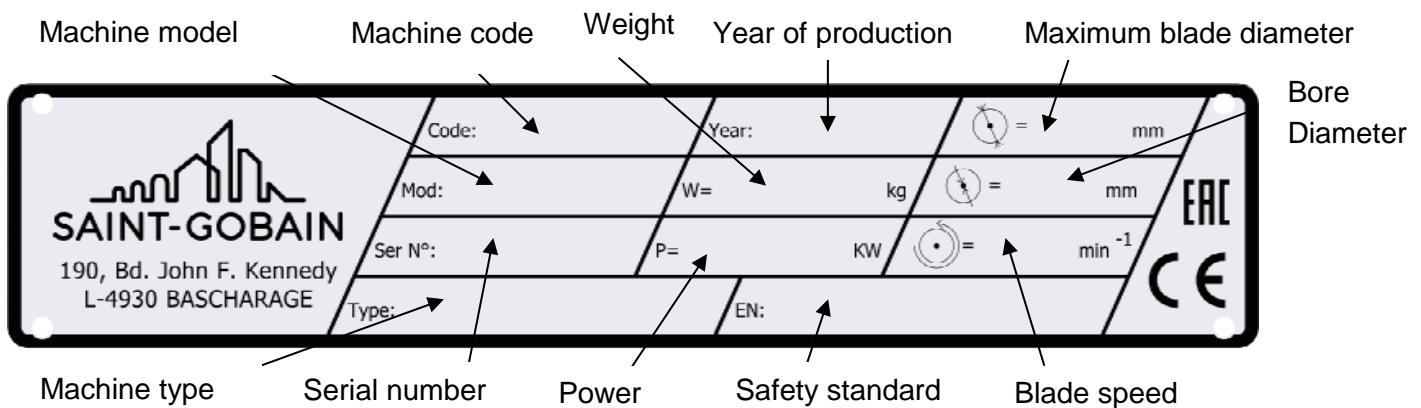

1.3 Safety instructions for particular operating phases

Before starting the work

- Before commencing work, make yourself familiar with the working environment at the place of use. The working environment includes: obstacles in the area of work and manoeuvre, the firmness of the floor, necessary protection at the site relating to public thoroughfares and the availability of help in the event of accidents.
- Check for correct mounting of the blade regularly.
- Immediately remove damaged or badly worn blades, as they endanger the operator whilst rotating.
- Only fit NORTON diamond blades to the machine! The use of other tools can damage the machine!
- Attention is drawn to the use of BS2092 safety goggles in conformity with specified Processes No.8 of the Protection of Eyes Regulation 1974, Regulation 2(2) Part 1.
- Use of ear and hand protection is compulsory.
- For security reasons, never leave the machine unattended, untied or unlocked.

While the engine is running

- Do not move the machine whilst the blade is running idle.
- Always cut with the blade guard in position.

2 MACHINE DESCRIPTION

Any modification, which could lead to a change in the original characteristics of the machine, may be done only by Saint-Gobain Abrasives who shall confirm that the machine is still in conformity with the safety regulations.

2.1 Short description

The CM 35 Masonry saw is designed for durability and high performance for onsite operations of a wide range of construction products. As with all other CLIPPER products, the operator will immediately appreciate the attention given to detail and quality of materials used in construction. The machine and its component parts are assembled to high standards assuring long life and minimum maintenance.

2.2 Purpose of use

The CM 35 Mini Clipper is designed to cut paving-stone brique and construction products. **It is not designed for cutting wood or metals.**

2.3 Layout

1. Handle
2. Start switch.
3. Blade guard .
4. Motor.
5. Blade.
6. Rolling cart.
7. Rolling cart locking bolt.
8. Adjustable legs
9. Anti-tilting.
10. Chassis.
11. Vacuum cleaner feed.
12. Tools.
13. Height adjustment lock handle.
14. Water feed pipe.

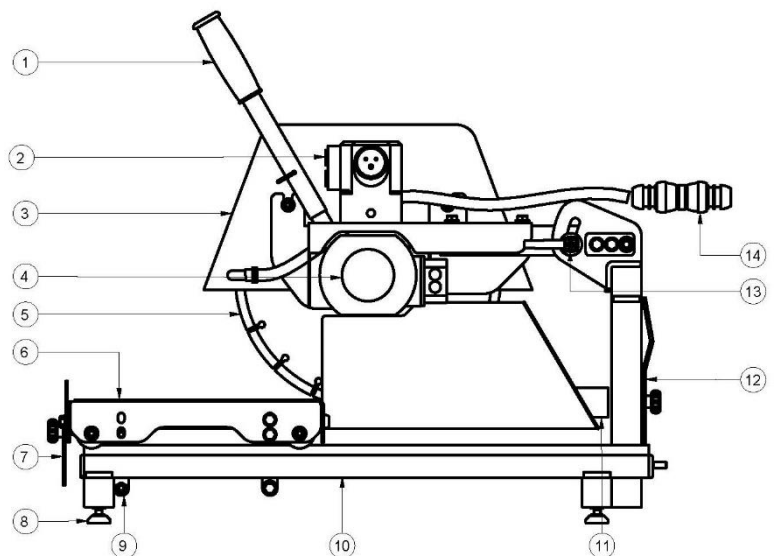

Handle (1)

The steel made handle allow an easy use of the machine.

Blade guard (3)

Jig-welded steel construction with 350mm-diameter blade capacity, which offers maximum operator protection and increased visibility of the work piece.

Incorporated in the blade guard is an outer metal cover, which can be easily removed to allow easy access to shaft for inspection and blade replacement when motor is switched off, while fully protecting the blade when in operation.

Electric motor and start switch (4) et (2)

2.2 kW electric motor and start/stop machine switch.

Blade (5)

Diamond blade.

Rolling cart (6)

Steel welded construction with non-slip top. Precise positioning of the material is possible thanks to the large surface area of the conveyor cart and the variable angle guide-a-cut.

Rolling cart locking bolt (7)

For safer transportation and avoid movement of the rolling cart, the rolling cart can be locked on the chassis.

Adjustable legs (8)

Legs adjustment for machine stabilization in the working area.

Anti-tilting (9)

Rolling cart anti-tilting system.

Chassis (10)

Chassis of the machine.

Vaccum cleaner feed (11)

The machine is equiped with a dust collector. The collector is composed by an output allowing the connection with a vaccum cleaner. The collector is able to absorb dust and construction products fragments during the cutting operation.

Tools (12)

Tools for diamand blade change.

Height adjustment lock handle (13)

Cutting hight adjustment system.

Water feed pipe (14)

Quick water feeding connector.

2.4 Technical data

Electric motor	2,2 kW 230V with thermal overload protection or 2.2kW 110V with thermal overload protection
Electric motor protection	IP54
Max. blade diameter	350mm
Bore	25,4mm
Rotation speed of the blade	2800 min ⁻¹
Cutting depth	100mm (without reversing the material)
Max. cutting length	270mm
Rolling cart dimensions (L x l)	280X340mm
Machine dimensions (L x l x H)	781x508x683mm
Complet machine	40 kg
Sound pressure level	80 dB (A) (ISO EN 11201)
Sound energy level	92 dB (A) (ISO EN 3744)

2.5 Statement regarding the vibration emission

Declared value of vibration emission following **EN 12096**.

Machine Model / code	Measured value of vibration emission at m/s ²	Uncertainty K m/s ²	Tool used Model / code
CM 35 mini clipper 230V 70184603115 CM 35 mini clipper 110V 70184607578	<2.5	0.5	Clipper ALFA

- The vibration value is lower and does not exceed 2.5 m / s.
- Values determined using the procedure described in the standard **EN 12418**.
- The measurements are made with new machines. Actual values may vary with site conditions, in terms of:
 - Materials worked
 - Wear Machine
 - Lack of maintenance
 - Inappropriate tool for application
 - Tool in poor condition
 - Unskilled operator
 - Etc...
- The exposure time to vibration is based on the performance of work (related to the adequacy Machine / Tool / worked material / operator)

When evaluating risks due to hand-arm vibration, you need to take into account effective usage at rated power of machine during a full day of work; quite often you will realise that effective utilisation time represents around 50% of overall duration of work. You have to consider, of course, breaks, water feeding, preparation of work, time to move the machine, disk mounting...

2.6 Statement regarding noise emission

Declared value of noise emission following **EN ISO 11201** and **NF EN ISO 3744**.

Machine Model / code	Sound Pressure level L_{Peq} EN ISO 11201	Uncertainty K (Sound Pressure level L_{Peq} EN ISO 11201)	Sound power level L_{Weq} NF EN ISO 3744	Uncertainty K (Sound power level L_{Weq} NF EN ISO 3744)
CM 35 mini clipper 230V 70184603115 CM 35 mini clipper 110V 70184607578	80 dB(A)	2.5 dB(A)	92 dB(A)	4 dB(A)

- Values determined using the procedure described in the standard **EN 12418**.
- The measurements are made with new machines. Actual values may vary with site conditions, in terms of:
 - Wear Machine
 - Lack of maintenance
 - Inappropriate tool for application
 - Tool in poor condition
 - Unskilled operator
 - Etc...
- Measured values relate to an operator in normal use, as described in the manual position.

3 ASSEMBLY AND COMMISSIONING

The machine is delivered fully equipped (although without diamond blade). It is ready for operation when you mount the diamond blade, the handles and the conveyor cart and after you connect to the appropriate power supply.

3.1 *Tool assembly*

Only NORTON blades with a maximum diameter of 350 mm can be used with the CM 35. All tools used must be selected with regard to their maximum permitted cutting speed for the machine's maximum permitted rotation speed. Before mounting a new blade into the machine, switch off the machine and isolate it from the main source of electricity.

To mount a new blade, follow these steps:

- Loosen the screw in front of the blade guard and disconnect the water hose on its the left side and open it.
- Loosen the hexagonal nut on the blade shaft (**attention:** left threaded), which holds the removable outer flange, with the supplied wrench.
- Remove the outer flange.
- Clean the flanges and blade shaft and inspect for wear.
- Mount the blade on arbour ensuring that direction of rotation is correct. Wrong direction of rotation blunts the blade quickly.
- Replace outer blade flange.
- Tighten the hexagonal (**attention:** left threaded), nut with the supplied wrench.
- Close the blade guard, retighten the screw on the front of the blade guard and reconnect the water hose.

ATTENTION: The blade bore must correspond exactly to the diameter of the blade shaft. Cracked or damaged bore is dangerous for the operator and for the machine.

3.2 *Electrical connections*

Check that,

- The voltage/phase supply corresponds to the information indicated on the motor plate.
- Available power supply must have ground connection in conformity with safety regulations.
- The connecting cables should have at least a 2.5mm²-section per phase.

3.3 *Starting the machine*

1. Place the machine on a flat well illuminated location. Use the adjustable legs to ensure the stability while using the machine.
2. Mount the handle and secure it with the bolt.
3. Mount the blade as previously described.
4. Release the rolling cart from the brake.
5. Set the right cutting depth with the rotation lock handle.
6. Plug the machine in the power supply socket and check that the blade runs in the right direction.
7. Connect the flexible hose of the vacuum cleaner to the waste socket of the machine and to the power supply.
8. Connect the machine to the water supply if a wet cutting is needed.
9. Start cutting.

4 TRANSPORT AND STORING

4.1 *Securing for transport*

Before transporting the machine, always remove the blade. Lock the conveyor thanks to the latch.

4.2 *Transportation procedure*

The machine could be transported alone with a two-wheel hand truck or manually with the help of a second person.

The machine does not have lifting hooks.

4.3 *Long period of inactivity*

If the machine is not going to be used for a long period, please take the following measures:

- Completely clean the machine
- Empty the water system

The storage site must be clean, dry and at a constant temperature.

5 OPERATING THE MACHINE

You will find in this chapter some advice about where and how to put up the machine.

5.1 Jobsite

5.1.1 Siting the machine

- Remove from the site anything, which might hinder the working procedure!
- Make sure the site is sufficiently well lit!
- Observe manufacturer's conditions for connecting to power supplies!
- Place electric cables in such a way that damage is excluded!
- Make sure you have a continual adequate view of the working area so you can intervene in the working process at any time!
- Keep other staff out of the area, so you can work securely.

5.1.2 Area dedicated for the use and maintenance of the machine

You should have 2 m in front of the machine and 1,5 m on both sides to get a comfortable use of the machine.

5.2 Cutting methods

To use the machine correctly, you must face it with one hand on the handle of the cutting head, and the other on the conveyor cart. Always keep your hands away from the moving blade. Open the switch cover and press the green button to start the machine. To stop either use the red button or press directly on the switch front cover.

5.2.1 Full depth or fixed cutting

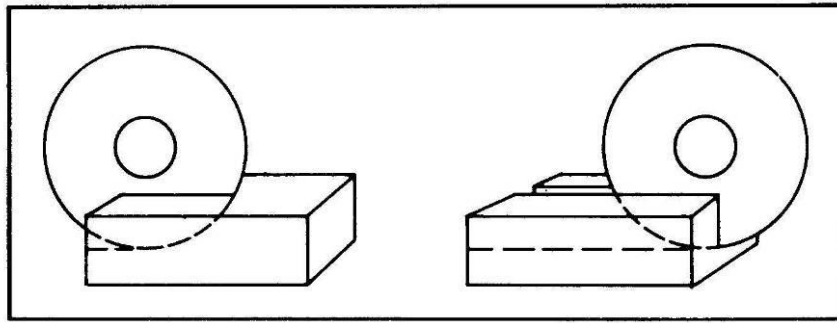

In full depth or fixed cutting, the cutting head is locked in a fixed position and the material is pushed into it as shown.

- Lower the cutting head to the desired cutting depth (in “through cutting”, lower cutting head until blade periphery reaches max. 3mm under the surface of the conveyor cart) by means of the handle on the blade guard
- Fix position by tightening the clamping device
- Put material on conveyor cart
- Start the machine
- Push the conveyor cart slowly and without undue pressure towards the rotating blade and cut the material as shown on the picture.

NOTE: While recommended, it is not absolutely necessary to lock the cutting head into a given depth position when jam cutting. The desired cutting depth can be maintained by holding firmly the depth feed handle on the blade guard. If the full depth of cut requires excessive pressure (on very dense material e.g.) make 2 or 3 shallow cuts.

5.2.2 Multiple step cutting

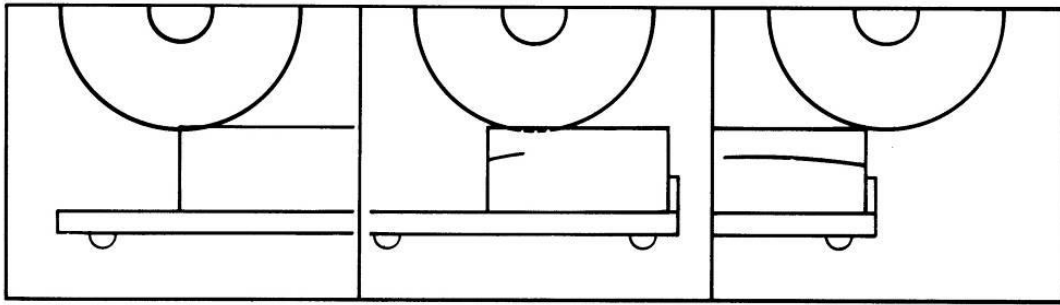

Multiple step cutting consists of moving the conveyor cart with the material to be cut back and forward under the rotating blade,

- Place the material to be cut on the conveyor cart firmly against the guide-a-cut and the backstop, keeping the hands well away from the blade.
- Start the machine.
- Move conveyor cart forward near the blade and pull down the cutting head until blade is lowered to a point where it will lightly contact the surface of the material.
- Pass the material beneath with rapid full length strokes, taking a shallow cut (approximately 3 mm deep as shown on the picture) on the forward. On the backward stroke, lift the blade just clear over the cutting line.
- Complete each rapid stroke backward and forward by passing the material beyond the centre of the blade before starting the reverse movement of the conveyor cart.

5.2.3 General advice for the cutting

- Material weight under 10 kg and having dimensions smaller than 280x340 can be cut with the machine.
- Before commencing work make sure the diamond blade is firmly seated!
- Select the right tools as recommended by the manufacturer depending on the material to be worked, the working procedure (dry or wet cut) to be carried out and the required efficiency.
- In case the thermal protection trips, wait until the motor has cooled down before starting the machine again.
- For security reason, every damaged tools or parts must be replaced.

6 MAINTENANCE AND SERVICING

To ensure a long-term quality from the cutting with the CM 35, please follow the maintenance plan below :

		At the beginning of a working day	During the change of tool	At the end of a working day	Every week	After a fault	After a damage
Whole machine	Visual control (general aspect, water tightness)						
	Clean						
Flange and blade fixing devices	Clean						
Motor cooling fans	Clean						
Water hoses and nozzles	Clean						
Cart guiding bars	Clean						
Motor housing	Clean						
Reachable nuts and screws	Tighten						

Maintenance of the machine

Always perform the maintenance of the machine with the machine isolated from the electrical supply.

Lubrication

The CM 35 uses life-lubricated bearings. Therefore, you don't need to lubricate the machine at all.

Cleaning of the machine

Your machine will last longer if you clean it thoroughly after each day of work, motor and blade flange.

7 FAULTS : CAUSES AND CURES

7.1 *Fault-finding procedures*

Should any fault occur during the use of the machine, turn it off, and isolate it from the electrical supply. Any works dealing with the electrical system or supply of the machine can only be carried out by a qualified electrician.

7.2 *Trouble-shooting guide*

ANOMALY	POSSIBLE CAUSE	SOLUTION
The motor does not start	Power failure	Check the power supply in the switch board. Check the position of the thermal magnet and the differential in the switch board. Make sure the extension cable is in a good state and well plugged in both ends.
	The thermal protection trips	Wait the motor to cool down and restart the thermal protection.
	Damaged switch	Replace it
	Blocked blade	Remove obstacles preventing the disk from turning.
Motor starts up very slowly and takes long to reach its revolutions	Damaged condenser.	Replace it
Insufficient cutting power	Bluntness in the disk segments or diamond rims.	Perform some cuts on abrasive material (sandstone, concrete, emery stone).
	Inappropriate blade.	Use the appropriate blade for the material to cut.
	Low motor power.	Let the motor be checked by a professional service technician.
The cooling water does not reach the disk	Hose obstructed	Release the water flow by cleaning the hose
Blade worn to fast	Unsuufficient cooling for diamond	Check blade cooling system.
	Excessive pushing pressure on the cutting.	Release pushing pressure.
	Inappropriate blade.	Use the appropriate blade for the material to cut.
Faulty Cutting	The machine is not properly	Align as indicated on this instructions book.
	Blade deteriorated or worn-out.	Change the blade.
	Inappropriate blade.	Use the appropriate blade for the material to cut.
Vibrations occurrence	Blade runs unbalanced.	Check the state of the disc and mount it
	Faulty blade fastening.	Make sure the blade clamps and the motor shaft are properly secured. Tighten well the nut.
	Warped blade.	Change the blade.
Excessive dust	Stuck filter in vacuum cleaner.	Clean frequently the vacuum cleaner filter.

7.3 *Circuit Diagram 230V*

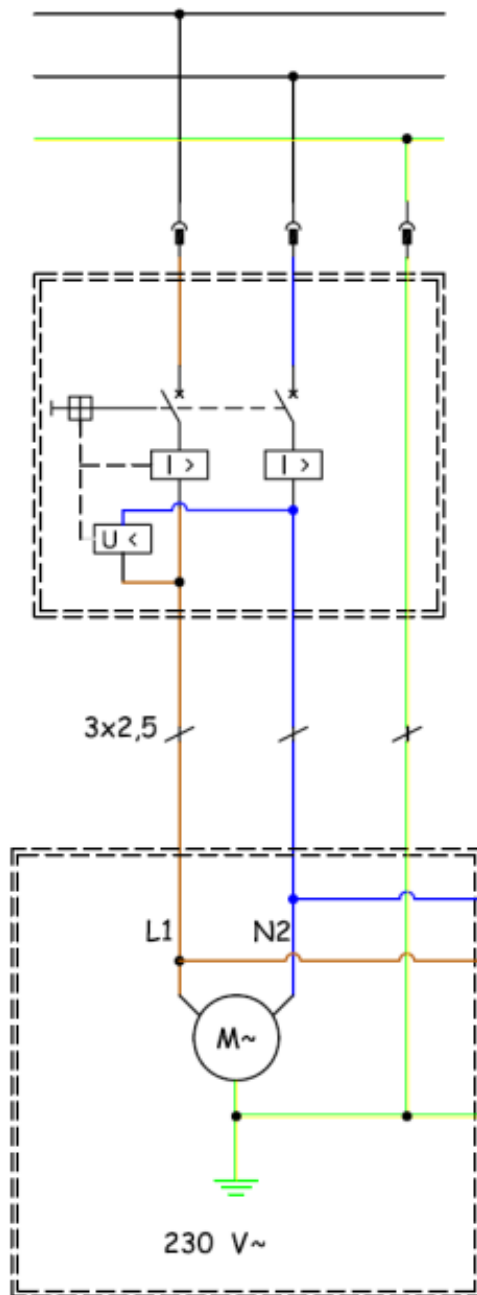

7.4 Circuit Diagram 110V

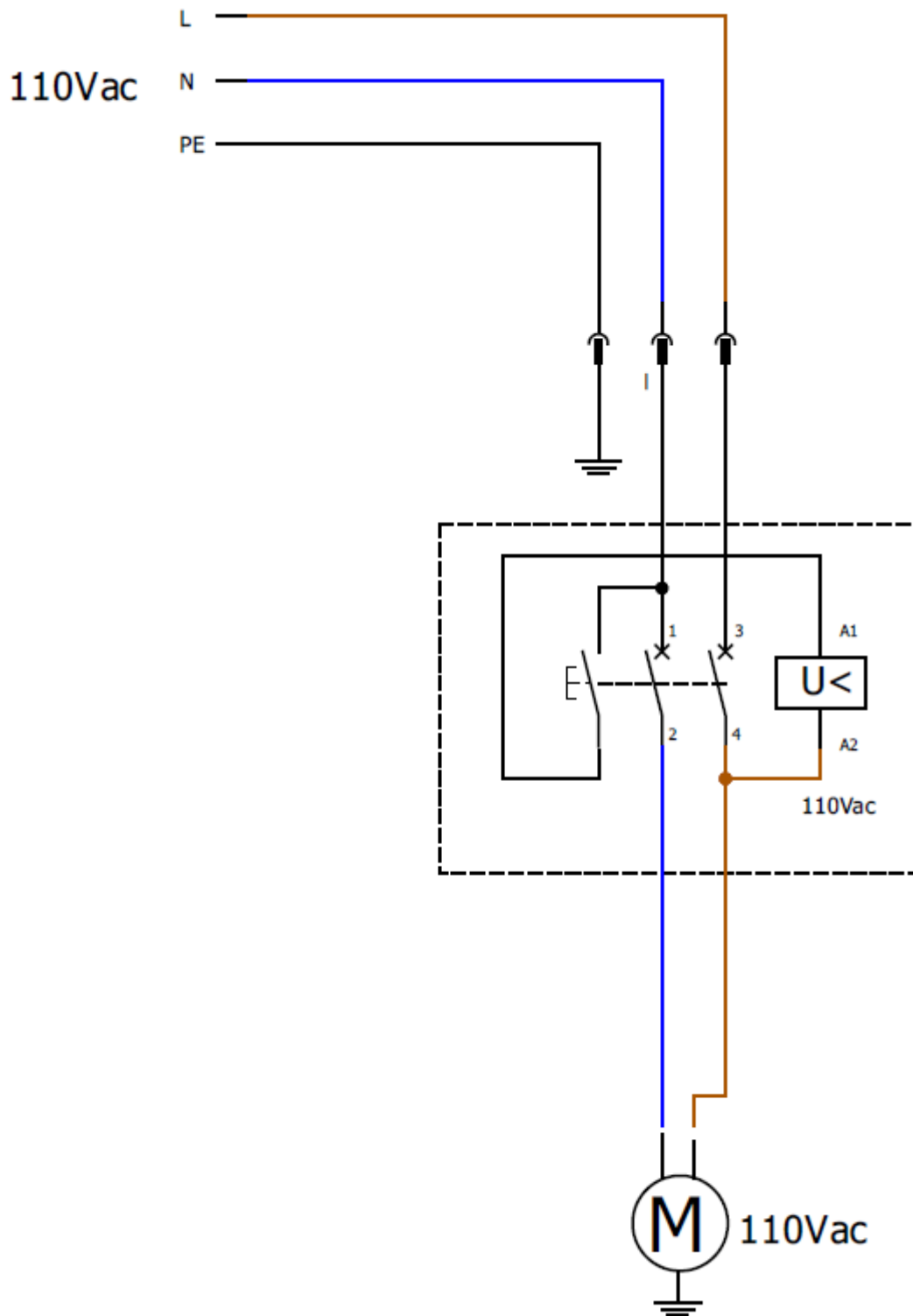

7.5 Customer service

When ordering spare parts, please mention:

- The serial number (7 digits).
- The code of the part.
- The exact denomination.
- The number of parts required.
- The delivery address.
- Please indicate clearly the means of transportation required such as "express" . Without specific instructions, we will forward the parts through the means which seem appropriate to us --- but which is not always the quickest way.

Clear instructions will avoid problems and faulty deliveries.

If not sure, please send us the defective part.

In the case of a warranty claim, the part must always be returned for evaluation.

This machine has been manufactured by: Saint-Gobain Abrasives S.A.:
190, Bd. J. F. Kennedy
L-4930 BASCHARAGE
Grand-duché de Luxembourg
Tel. : 00352 50 401 1
Fax. : 00331 83717792
http://www.construction.norton.eu
e-mail : sales.nlx@saint-gobain.com

7.6 Spare parts

In order to consult the spare parts lists, we invite you to visit the after-sales website of Norton Clipper by using the following address:

<https://spareparts.nortonabrasives.com>

For a quick access, you can also use the QR Code shown below using your mobile phone:



This electronic catalogue provides exploded views and spare parts lists for different machines designed by Norton Clipper so you can find references you need.

Guarantee can be claimed and technical support obtained from your local distributor where machines, spare parts and consumables can be ordered as well:

SAINT-GOBAIN ABRASIVES NV/SA
INDUSTRIELAAN 129
1070 ANDERLECHT/BRUSSEL
BELGIUM
TEL: +32 (0)2 267 21 00
FAX: +32 (0)2 267 84 24

SAINT-GOBAIN ABRASIVES, S.R.O.
POČERNICKÁ 272/96, MALEŠICE
108 00 PRAHA 10
CZECH REPUBLIC
TEL: +420 255 719 326
FAX: +420 255 719 321

SAINT-GOBAIN ABRASIVES A/S
ROBERT JACOBSENS VEJ 62A
2300 KØBENHAVN S
DENMARK
TEL: +45 4675 5244

PO BOX 643706
FORTUNE TOWER OFFICE 2106
JLT BLOCK C
(NEXT TO METRO STATION)
JUMEIRA LAKE TOWER, DUBAI
UNITED ARAB EMIRATES
TEL: +971 4 431 5154
FAX: +971 4 431 5434

SAINT-GOBAIN ABRASIFS
RUE DE L'AMBASSADEUR - B.P.8
78 702 CONFLANS CEDEX
FRANCE
TEL: +33 (0)1 34 90 40 00
FAX: +33 (0)1 39 19 89 56

SAINT-GOBAIN ABRASIVES GMBH
BIRKENSTRASSE 45-49
D-50389 WESSELING
GERMANY
TEL: +49 (0) 2236 703-1
+49 (0) 2236 8996-0
+49 (0) 2236 8911-0
FAX: +49 (0) 2236 703-367
+49 (0) 2236 8996-10
+49 (0) 2236 8911-30
FÜR DEN FACHHANDEL
ÖSTERREICH
TEL: +43 (00) 662 430 076

SAINT-GOBAIN ABRASIVES KFT.
1225 BUDAPEST
BÁNYALÉG U. 60/B.
HUNGARY
TEL: +36 1 371 22 50
FAX: +36 1 371 22 55

SAINT-GOBAIN ABRASIVI S.P.A
VIA PER CESANO BOSCONI 4
I-20094 CORSICO MILANO
ITALY
TEL: +39 02 44 851
FAX: +39 02 44 78 266

SAINT-GOBAIN ABRASIVES S.A.
190 RUE J.F. KENNEDY
L-4930 BASCHARAGE
GRAND DUCHE DE LUXEMBOURG
TEL: +352 50 401 1
FAX: +331 83 717 792
NO. VERT (FRANCE) 0800 906 903

SAINT-GOBAIN ABRASIFS, S.A.
2 ALLÉE DES FIGUIERS
AIN SEBAË - CASABLANCA
MOROCCO
TEL: +212 5 22 66 57 31
FAX: +212 5 22 35 09 65

SAINT-GOBAIN ABRASIVES BV
GROENLOSEWEG 28
7151 HW EIBERGEN
P.O. BOX 10
7150 AA EIBERGEN
THE NETHERLANDS
TEL: +31 545 466466
FAX: +31 545 474605

SAINT-GOBAIN ABRASIVES AS
POSTBOKS 11, ALNABRU,
0614 OSLO
BROBEKKVEIEN 84,
0582 OSLO
NORWAY
TEL: +47 63 87 06 00
FAX: +47 63 87 06 01

SAINT-GOBAIN HPM POLSKA SP. Z O.O.
UL. NORTON 1
62-600 KOŁO
POLAND
TEL: +48 63 26 17 100
FAX: +48 63 27 20 401

SAINT-GOBAIN ABRASIVOS, L. DA
ZONA INDUSTRIAL DA MAIA
I-SECTOR VIII, NO. 122
APARTADO 6050
4476 - 908 MAIA
PORTUGAL
TEL: +351 229 437 940
FAX: +351 229 437 949

SAINT-GOBAIN GLASS
BUSINESS UNIT ABRASIVI
PUNCT DE LUCRU: LOC.VETIS, JUD.
SATU MARE 447355
STR. CAREIULUI 11
PARC INDUSTRIAL RENOVATIO
ROMANIA
TEL: 0040-261-839.709
FAX: 0040-261-839.710

SG HPM RUS
58, F. ENGELS STR.
STROENIE 2
105082 MOSCOW
RUSSIA
TEL: +74 955 408 355
FAX: +74 959 373 224

SAINT-GOBAIN
ABRASIVES (PTY) LTD
2 MONTEER ROAD
ISANDO 1600
P.O. BOX 67
SOUTH AFRICA
TEL: +27 11 961 2000
FAX: +27 11 961 2184/5

SAINT-GOBAIN ABRASIVOS, S.A.
CTRA. DE GUIPÚZCOA, KM. 7,5
E-31195 BERRIOPLANO (NAVARRA)
SPAIN
TEL: +34 948 306 000
FAX: +34 948 306 042

SAINT-GOBAIN ABRASIVES AB
BOX 495
SE-191 24 SOLLENTUNA
SWEDEN
TEL: +46 8 580 881 00
FAX: +46 8 580 881 01

SAINT-GOBAIN INOVATIF
MALZEMELER VE AŞINDIRICI
SAN. TIC. A.Ş.
GOLD PLAZA, ALTAY ÇEŞME
MAHALLESİ, ÖZ SOKAK, NO:19/16
34843 MALTEPE-İSTANBUL,
TURKEY
TEL: 0090-216-217 12 50
FAX: 0090-216-442 40 74

SAINT-GOBAIN ABRASIVES LTD.
DOXEY RD
STAFFORD
ST16 1EA
UNITED KINGDOM
TEL: +44 1785 222 000
FAX: +44 1785 213 487



Saint-Gobain Abrasifs
190 Rue J.F. Kennedy
L-4930 Bascharage
Grand Duche de Luxembourg
Tel: +352 50 4011
Fax: +331 83 717 792
no. vert (France) 0800 906 903

www.nortonabrasives.com/fr-fr