

# Alldrive 1 Tonne Hi-Tip

HYDROSTATIC

## Specifications

Dimensions (mm)	
A	3032
A'	3192
B	1115 (982 <sup>A</sup> )
C	1773
D	1155
E	982
F	1500
G	274
H	1262
I	654
J	346
K	505
L	3005
M	1913
N	1573
O	720
P	2860
R	2370

<sup>A</sup> with optional narrow wheels

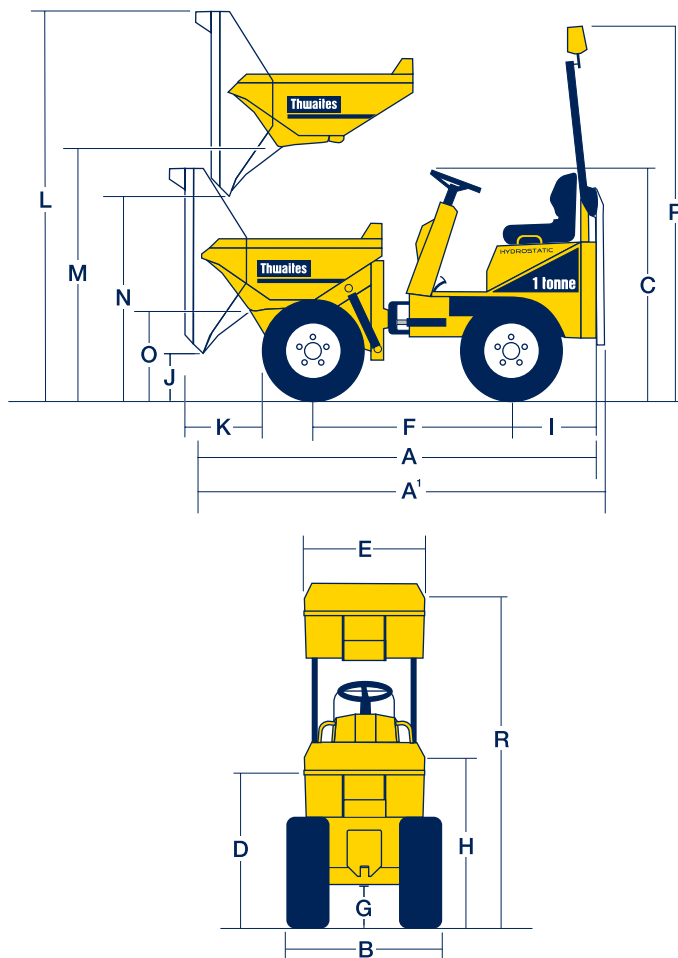

Model	Max. Safe Load	Skip				Drive	Transmission	
	Tonnes	Front Tip	Powerswivel	Hi-Swivel	Hi-Tip		Powershuttle	Powershift
Alldrive 9	9	•				4x4	•	•
Alldrive 7	7	•				4x4	•	•
Alldrive 6	6	•	•			4x4	•	•
Alldrive 5	5	•	•			4x4	•	•
Alldrive 4.5	4.5	•	•			4x4	Hydrostatic	
Alldrive 4	4	•	•			4x4	Manual	
Alldrive 3.5	3.5	•	•	•*		4x4	Hydrostatic	
Alldrive 3	3	•	•	•		4x4	Manual	
Alldrive 2.3	2.3	•	•			4x4	Hydrostatic	
Alldrive 2	2	•	•			4x4	Manual/Hydrostatic	
Alldrive 1.5	1.5			•		4x4	Manual/Hydrostatic	
Alldrive 1	1		•		•	4x4	Hydrostatic	

\* 3 Tonne Max. safe load.

# Alldrive 1 Tonne Hi-Tip

## HYDROSTATIC

### Specifications

<b>Capacities</b>	Max. safe load	1000 kg
	Heaped	500 litres
	Struck	400 litres
	Water	280 litres

#### Engine

Yanmar 3TNV76, 15.9 kW/21.4 bhp (nett) @ 2800 rpm, three-cylinder water-cooled diesel. Max torque 66.4 Nm (49 lb f ft). Electric starting, hour meter, battery isolator switch and heavy-duty cyclonic air cleaner positioned within the lockable engine compartment.

#### Noise Levels

Operator's ear 84 LpA, airborne sound power level 102 LwA (to 2000/14/EC).

<b>Speeds</b>	Forward/reverse:	0–12 km/h
---------------	------------------	-----------

<b>Tyres</b>	<b>Standard</b>	<b>Optional</b>
	10.0/80 x 15.3	7.00 x12
	8 ply	6 Ply
	Track grip tread	Track grip tread

#### Brakes

Automatic failsafe braking system incorporated into rear drive motors.

#### Chassis

Front and rear chassis constructed from folded steel plate, with centre-point articulation and oscillation for optimum stability and traction.

#### Drive System

Hydrostatic with variable displacement pump feeding four wheel motors, incorporating "Twin-Lock" system to maximise traction.

#### Skip

Hydraulically operated, 3 mm base, 4 mm sides steel plate. Mouth reinforced with box sections giving greater strength to minimise damage, no material traps. Raise and tip control operated by twin control levers.

#### Seating & Controls

Column-mounted forward/reverse lever with foot pedal speed control. Adjustable suspension seat, accessible from both sides. Audible warning device at key start 'on' position. Super-bright warning lights for all critical functions. Electric horn.

#### Service Access

Lockable three-sided cover provides easy access from ground level to engine service points.

#### Electrics

Wiring harness contained within conduits and all electrical components water resistant to IP65/67 standards.

#### Steering & Hydraulics

Hydraulic power steering. Return line filtration for all services and large capacity suction strainer in the tank to give full circuit protection. Hydraulic test point fitted as standard.

<b>Tank Capacities</b>	Fuel	21 litres
	Hydraulic	20 litres

<b>Shipping Cube</b>	6.3 m <sup>3</sup> (with folded ROPS)
----------------------	---------------------------------------

<b>Unladen Weight</b>	1190 kg
-----------------------	---------

<b>Clearance Diameter</b>	5.45 m
---------------------------	--------

#### ROPS/Beacon

A folding ROPS bar and beacon are fitted as standard.

#### Optional Extras

Full road lighting equipment. Reverse alarm. UK road equipment. Towing bracket. Grassland/sand tyres and narrow tyres.



# Thwaites



We reserve the right to change all specifications without prior notice.  
Printed in England 04/2005.