



Model: Armorgard

Description: Pipe Rack

Model: PR2



Specification

Piperack

Product code: PR2

Mobile rack for storing and transporting long lengths of material.

Unique fold down design allowing them to be stacked.

Available in 1 or 2 tonne storage capacity.

Product specifications

Dimensions

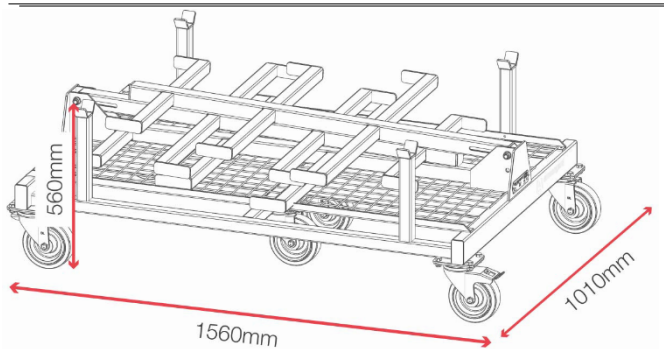

Colour	Jet black: RAL 9005
Finished coating	Powder coated
Material & thickness	5mm & 3mm steel
How are castors fitted?	Quick-fix bolt on heavy-duty castor kit
Assembly required?	Yes
Weight	101kg

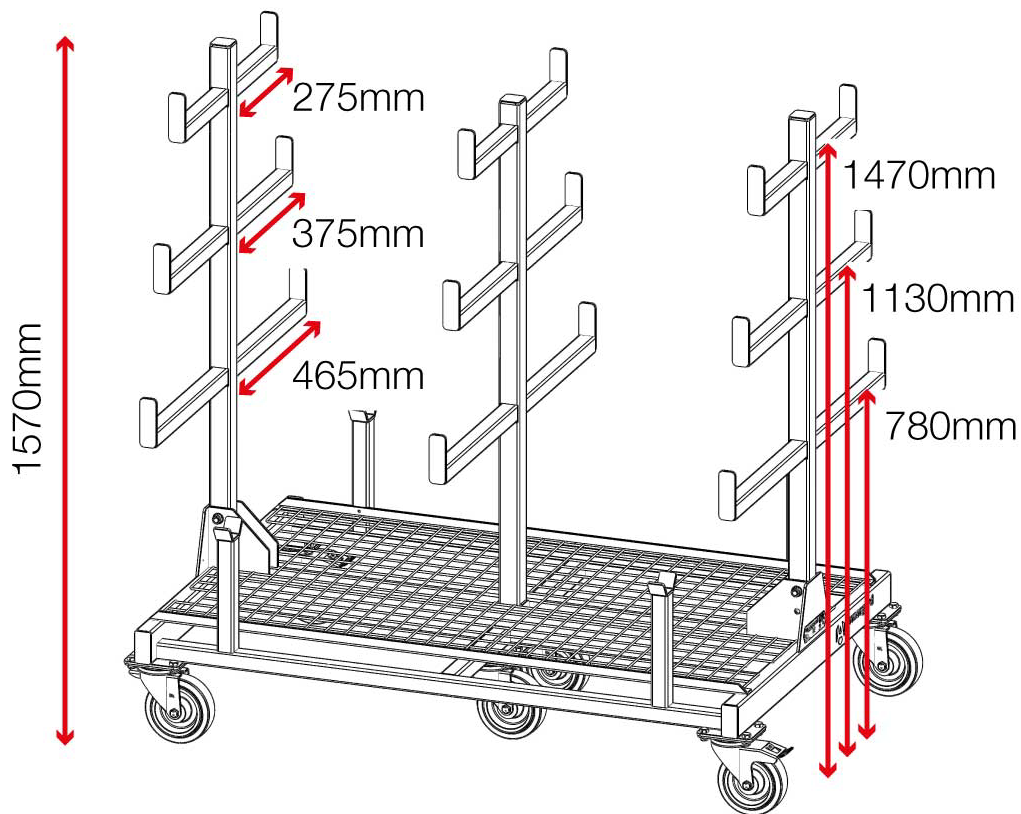

Easy and quick way to move pipes and tubing. The adaptable mobile on-site pipe and conduit storage solution. The PipeRack™ is an innovatively designed wheeled storage rack to manoeuvre while you're working on site. Each unit has been fully tested and certified to guarantee you a top quality product that is durable and built to last, while the fully collapsible design means that it can be easily transported and stored when not in use. PipeRack™ is certificated and suitable for storing up to 2 tonne storage capacity. Not to be moved whilst fully loaded.