



# INSTALLATION INSTRUCTIONS

## Weatherguard Tripod - Site Tripod Heads

Product Codes: **WGS220Y/TH, WGS220Y-E/TH, WGS525Y/TH, WGS525Y-E/TH**

### Safety Warning



- The installation should be carried out by a qualified electrician in compliance with the current edition of the IEE Wiring Regulations.
- Prior to installation, carry out the necessary risk assessment considering the people who could be at risk, the level of risk and the precautions required to control the risk
- Ensure that the circuit supply is isolated either by the circuit supply fuse being removed or the applicable circuit breaker being turned off before installation or any maintenance.
- Check the total load on the circuit ensuring the luminaire does not exceed the rating of the circuit cable, fuse or circuit breaker.
- Long-term use and voltage fluctuations can reduce the life span of the fitting.
- If the fitting incorporates control gear, ensure careful sizing to avoid instances of nuisance tripping of the protective device used in the installation.
- Follow the provided installation instructions, using the fixings supplied or recommended.
- Keep out of reach of children.



### Specification

**Box Contents -**  
1 x 110V 25W LED Tripod Head

<b>Dimensions:</b>	Head: L: 664 /1562 x W: 72/103 x D: 78mm
<b>Material:</b>	Body & Diffuser: Polycarbonate Tripod: Steel
<b>Working Temperature:</b>	Standard: -25°C to 40°C Emergency: 0°C to 40°C
<b>Included:</b>	2 x Sockets

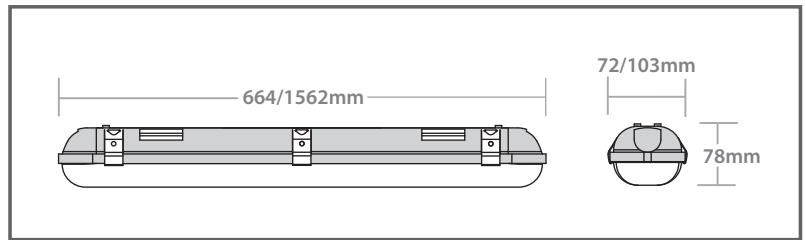

\*Batteries 2 year guarantee

### Installation Instructions

1. Remove the tripod head from the box, straighten the adaptor that is attached to the back and slide into the opening at the top of the LED tripod base (sold separately).

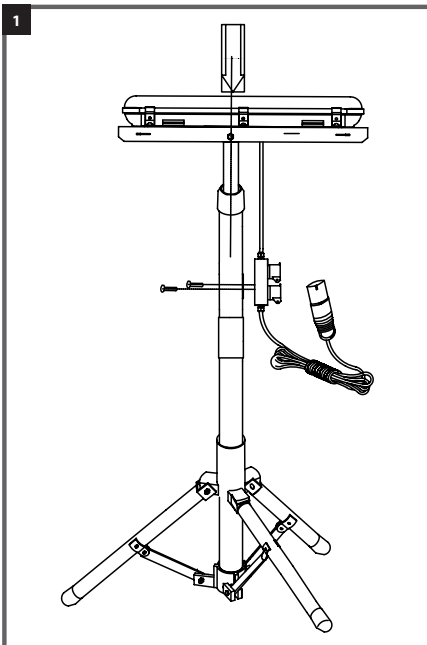

2. Attach the connector box to the tripod with the screws provided.
3. Plug in the cable provided to a suitable 110V transformer / power supply and test to make sure everything is working correctly.

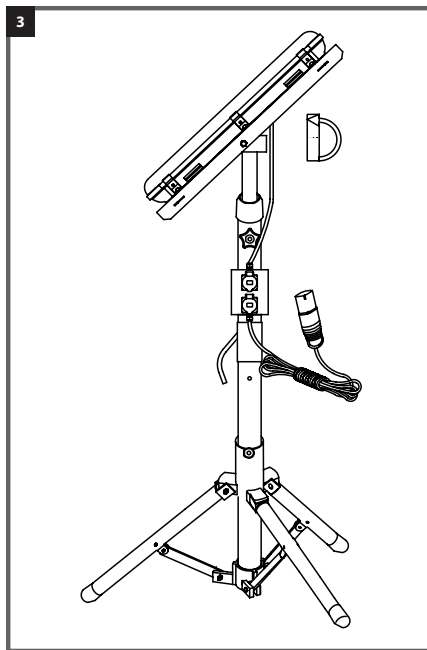
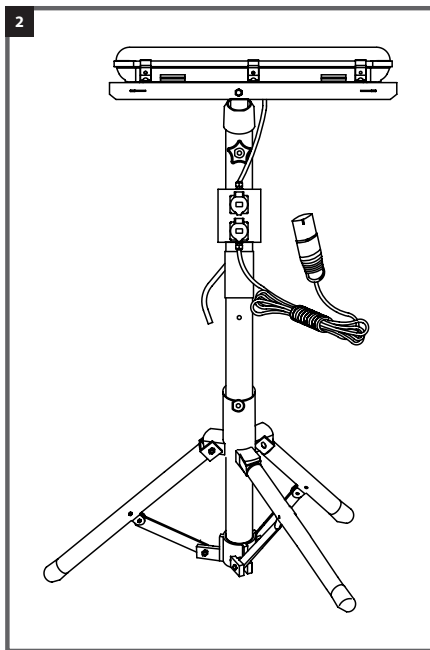

## Guarantee

This product is guaranteed for a period of 3 years (2 year for batteries) from the date of purchase. The guarantee is invalid in the case of improper use, tampering, removal of the Q.C. date label, installation in an improper working environment or installation not according to the current edition of the I.E.E. Wiring Regulations (BS7671). The guarantee is also invalidated if the luminaire has been insulation tested. Should this product fail during the guarantee period it will be replaced free of charge, subject to correct installation and return of the faulty unit. We do not accept responsibility for any installation costs associated with the replacement of this product. Your statutory rights are not affected. We reserve the right to alter specifications without prior notice.

## Maintenance

- This fitting will require routine cleaning if used in adverse (dust, paint, welding, oils etc) environments. Do not use solvents, aggressive detergents or abrasives.
- The light source & driver in this luminaire can be quickly and easily replaced at end of life. This should be carried out by a competent person. Contact Red Arrow for details of replacements.

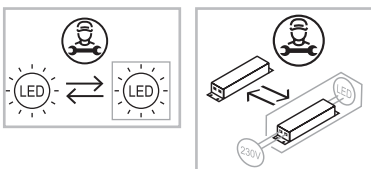

- When this fitting comes to the end of its life or you choose to replace it, please do not dispose of it with your normal waste. Please recycle where the facilities exist, check with your local authority for suitable options.

INS/SITE/0013/WGS\_TH/V3



Depot 1, 0208 850 5658  
 Depot 2, 0208 303 0708  
 Depot 3, 0208 850 9000

Email: [info@psmhire.co.uk](mailto:info@psmhire.co.uk)

[www.psmhire.co.uk](http://www.psmhire.co.uk)